

R·W·M



Lifting solutions
Electric chain hoists

R·W·M





Innovative hoist designs

quality design, reliability and safety features
production run of more than 60000 hoists

RWM can be summarised as a constantly evolving company that has been designing and producing its own electric chain hoists and associated products for over 30 years, with forward thinking, innovation, the application of the latest technology along with modern manufacturing facilities, it has seen its market share grow over the years to become one of the world leaders in the manufacture of electric chain hoists.

At RWM the search for quality and innovation always continues, with major investments in research and development, new modern production equipment and new manufacturing facilities. This in turn represents the manufacture of highest quality hoists.

RWM are currently operating from two centres, one which is the research and development centre and the other a modern manufacturing facility where the manufacture of the hoists takes place by highly trained and skilled personnel.

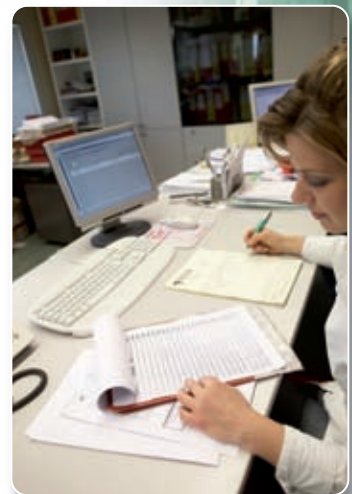

Over 30 years of experience

research and development
engineering and production made in Italy



RWM represents a tangible evolving process that has been developing electric chain hoists for over 30 years and which has seen its experience and capability of innovation create over 60,000 units.

It has serviced an array of sectors throughout the world and is considered a thriving force and world leader in the production of electric chain hoists.

The RWM chain hoist line can be distinguished by its innovative design, its superior quality and high standard of safety at a competitive cost. Three key factors that dictate and have become necessary in current markets.

RWM has been able to gather its own resources and market studies to distinguish the ever changing market needs, which in turn has brought about the creation of a vast line of products.

For RWM, the search for quality and the latest innovative production methods, is what we thrive for. We always look to modernize our production equipment and use the finest tools in production equipment which in turn create a higher quality hoist.

RWM currently operates in two facilities. One which focuses on research and development and the other where the assembly gets carried out by a joint effort between sophisticated machinery and highly trained and skilled personnel.





The reliability of RWM as manufacturer of electric chain hoists is confirmed by the CE and CSA marks. Every hoist is proof load tested before being delivered to the customer.

RWM hoist are constructed in full compliance with the following standards:

- Machinery Directive 98/37/CE.
- Low Voltage Directive (LVD) EEC/73/23.
- Electromagnetic Compatibility Directive (ECD) EEC/89/336–EEC/92/31.
- CSA (CLASS 9041 01 - Cranes and Hoists).

RWM hoists are distributed with the following documents:

- Certificate of Conformity (enclosure IIA).
- Manufactures statement (enclosure IIB).
- Certificates for the electromagnetic compatibility, load chain and hook.
- Installation and Maintenance manual.
- 2 year warranty from date of delivery.

Lifting solutions

electric chain hoists

in keeping with european laws

R·W·M

R·W·M

Versatility and Efficiency

capacities from 125 kg through to 5,000 kg

RWM has through experience and research evolved its range of electric chain hoists to match the needs of today's customer requirements. Available in the following.

The W series hoist, with capacities from 125 kg through to 2,000 kg, available with eye suspension, close coupled push, geared and power travel trolleys to give maximum headroom.

The new innovative WR series hoist, with capacities from 1000 kg through to 5,000 kg available with eye suspension, close coupled push, geared and power travel trolleys designed to give exceptional low headroom.

Both W & WR series hoists are available with a comprehensive range of single and dual speeds. Also available built as an ultra low headroom hoist for applications with restrictive height.

With the numerous combinations of hoists and available voltages RWM can offer a solution to any of your material handling requirements.

W Series

electric chain hoists



Technical dimensional details W serie

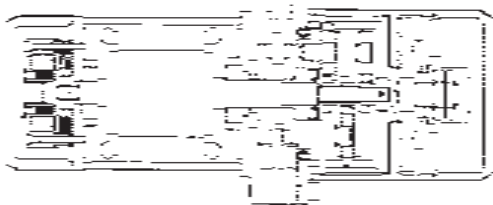

Electrical control panel

The panel is fully hard wired with all components mounted on a steel backing plate. The panel includes high quality contactor switches, a transformer for low voltage (24V) controls, brake rectifier, fuses and connector terminals.

Thanks to these high quality components, up to 240 operations per hour can be carried out. The electrical control panel is mounted in an IP65 plastic enclosure and follows the CEI-EN 60204 norms. In addition, the panel are fully compatible and interchangeable with a full range of hoist models.

Guide chain

The hoists central body and patented chain guide are machined from one single casting, this allows precise positioning of the load chain into the load sprocket.

The W-series range of electric chain hoists can be distinguished by the following; its extremely compact size giving the best possible closed headroom, its exceptional quality and its high levels of reliability. All are achieved by having the highest quality manufacturing standards, continuous improvements and quality control. All mechanical parts are examined under stringent conditions and rigorously tested, including long term performance testing to ensure the highest quality, efficiency and extended product life.

Lifting motor

The cylindrical parallel rotor is produced with single windings for single speed hoists or dual windings for dual speed hoists and all have class F insulation.

Manufacture in accordance with FEM class 2m, the duty cycle for single speed hoists is 40% and 10 + 30% for dual speed hoists. The supply voltage for these motors can be specified when ordering and they are available in a wide range of voltages, phases and hertz, thus making the RWM chain hoists again very versatile and capable of working in any environment.

The braking system of the chain hoist uses a 230V spring-activated electro magnetic brake which allows for quick and safe stopping allowing the load to be held at any desired height or position.

The chain hoist has an IP54 protection which protects it against dust, limited ingress and against low pressure jets of water from all directions, limited ingress, for standard indoor use. For other environments, please contact RWM.

Reduction gears

Found in the gear box's are epicycloid, totally enclosed and lubricated with a permanent high performance grease. The gears are manufactured from high tensile steel and are hardened and heat treated for smooth operation and maximum life span.

In addition, due to its sealed lubrication, the chain hoist can operate within a temperature range of -20°C to +60°C.

Overload by clutch

The slipping clutch is a safety device which limits both the up and down stroke of the chain hoist, by limiting a possible overload. It is constructed from asbestos free braking plates held under pressure by cup springs and is adjustable. Note: this is only a safety feature and should not be used as a working limit.

The clutch is setting at 15% respect the nominal capacity of hoist.



W Serie - Type F

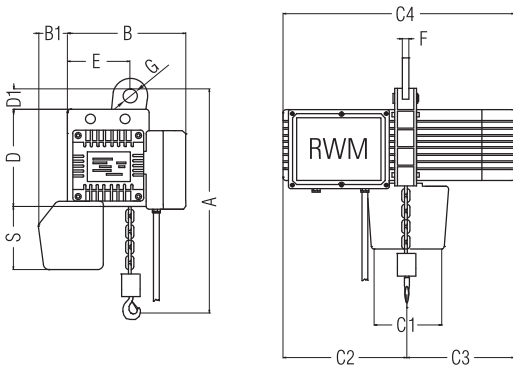

W Serie - Type CS

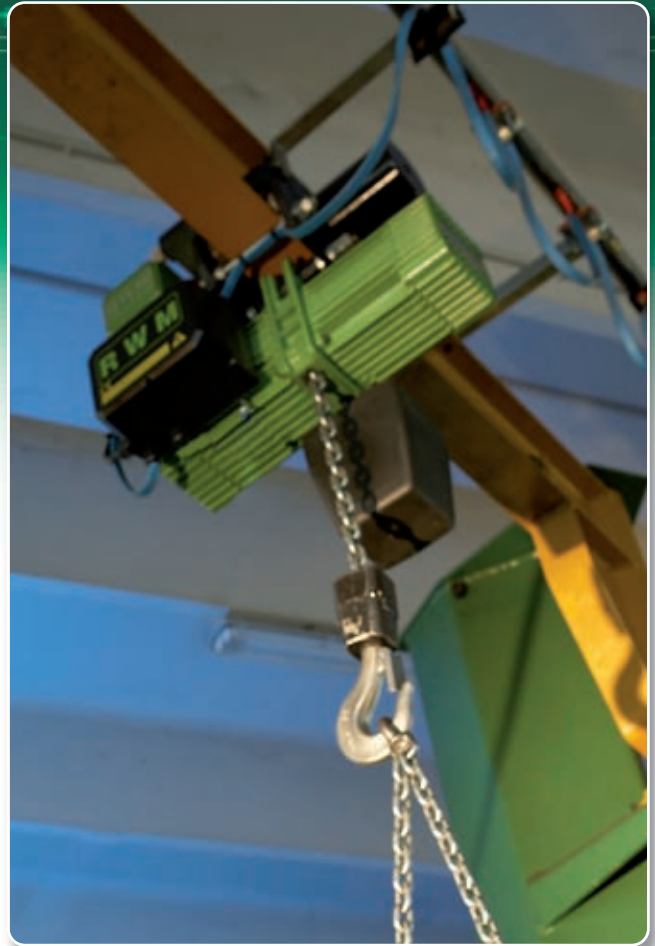
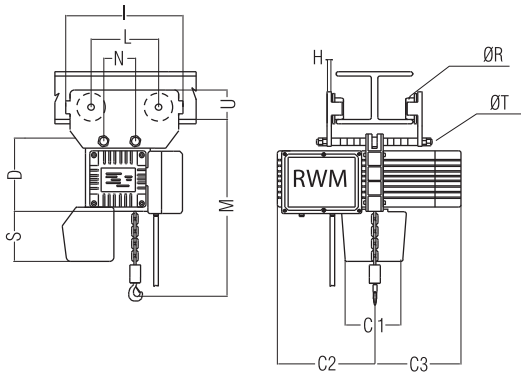

W Serie - Type CE

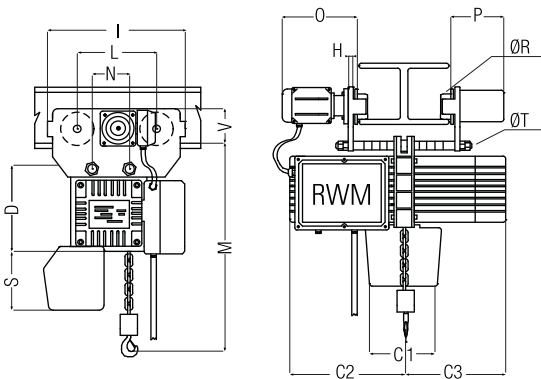

W Serie - Type CM

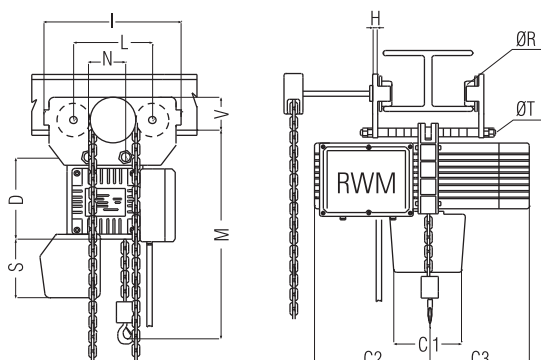

models **W Series**



Type F



Type CS



Type CE



Type CM

WR Series

electric chain hoists



WR series hoists are designed to lift loads from 1000 kg to 5000 kg in a production environment with a high duty cycle and proven reliability. The hoist body is completely manufactured completely from aluminium and steel with no plastic components. With the new design RWM have produced a hoist with the minimum low headroom and at the same time safe and reliable with particular attention to the selection and test of materials used.

Electric motor

The three phase motor is produced with single or double windings for single or dual speeds. The insulation is class F for both motors. Manufactured to FEM standard 2m, the WR hoists have a duty of 55% on single speed hoists and 15+40% on dual speed hoists. Standard operating voltage's 230/400V, 3 phase, 50 Hz, other voltages available on request.

Hoist motor protected to IP 55 against ingress of dust and water, upgradeable to IP 65 upon request. The hoists 3000/4000/5000 have a standard fan assisted motor for better cooling and increased duty cycles.

Reduction gear

The reduction gears are designed in such a way that the speed of the hoist can be changed simply by increasing or decreasing the number of components in the gearbox.

The gears are manufactured from high tensile steel and are hardened and heat treated to give maximum life. With the correct choice of oil the hoist can work within the following temperature range, -20°C to +60°C.

The **Hoist brake** is a 400 V AC electro magnetic brake type. The advantages of this 400v three phase brake are, high braking power, very strong structure and no transformer, the brake is manufactured from aluminium die-casting for good heat dissipation, the brake coil is fully encased in epoxy resin.

The brake disk is manufactured from asbestos free material.

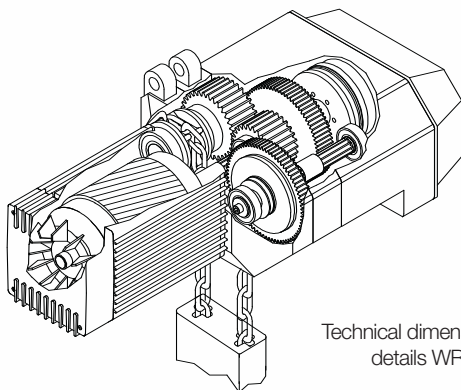

Technical dimensional details WR serie

RWM WR series hoists are supplied with **upper and lower electric limit switches** to prevent hook over travel and prevent the use the clutch as an ultimate limit and extending the life of the clutch and gearbox

They are manufactured with two micro switches that operate on the auxiliary circuit of the hoist contactors cutting out operating contactor in the direction of lift.

The hoists are also equipped with a slipping clutch that is set to 120% of the working load limit to prevent accidental overloading.

All hoists are manufactured to CEI EN60204 governing the safety of electrical equipment with low voltage controls 24v, via a transformer mounted in a steel enclosure within the hoist body.

Due to the high quality of electrical contactors used and the 400 vac brake RWM guarantee the WR series hoists for more than 240 operations per hour.



Type F dimensions

WR 2000 - Type F

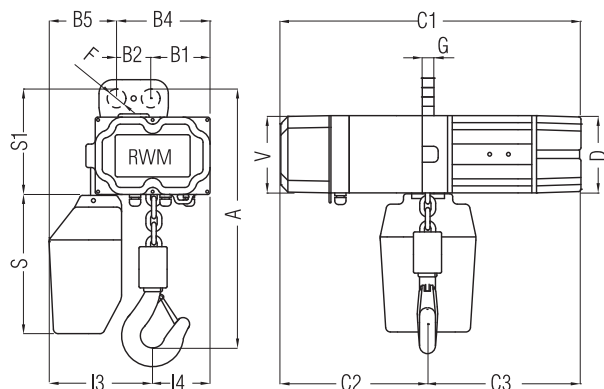

WR 3000/4000/5000 - Type F

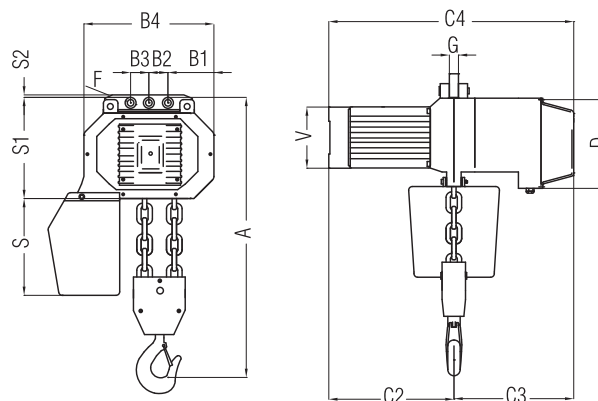

Type CS dimensions

WR 2000 - Type CS

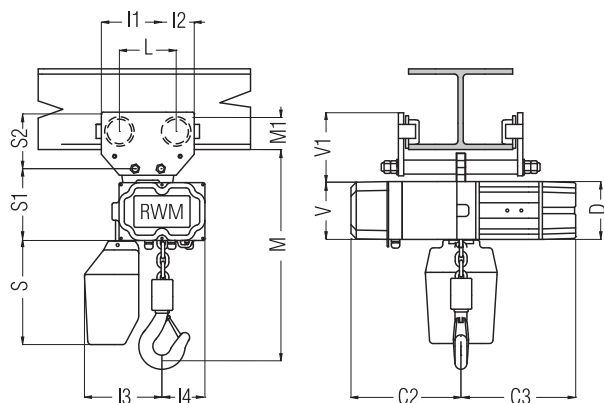

WR 3000/4000/5000 - Type CS

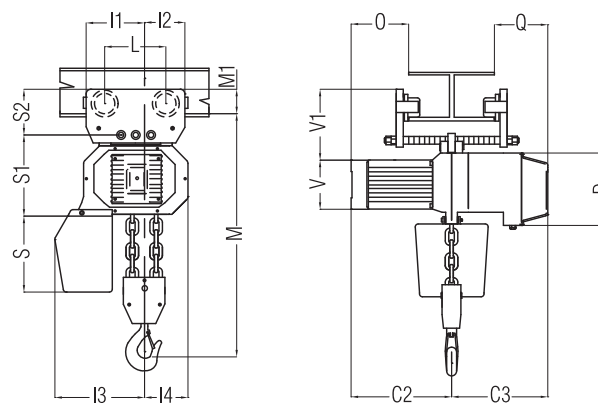

Type CE dimensions

WR 2000 - Type CE

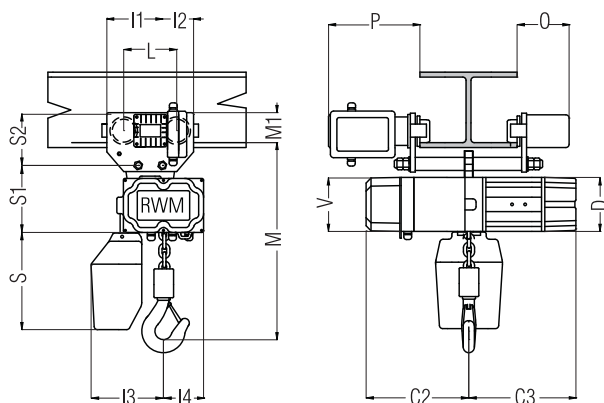

WR 3000/4000/5000 - Type CE

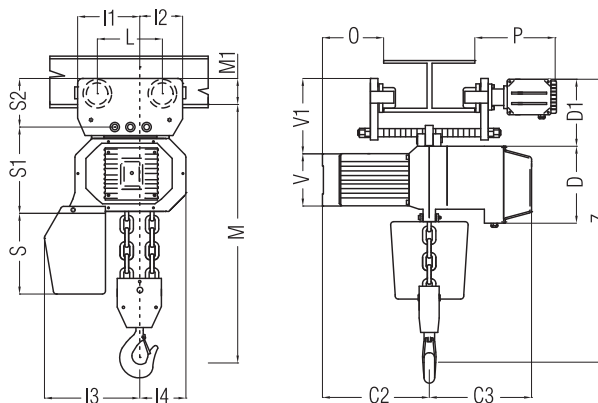

models **WR Series**



Type F

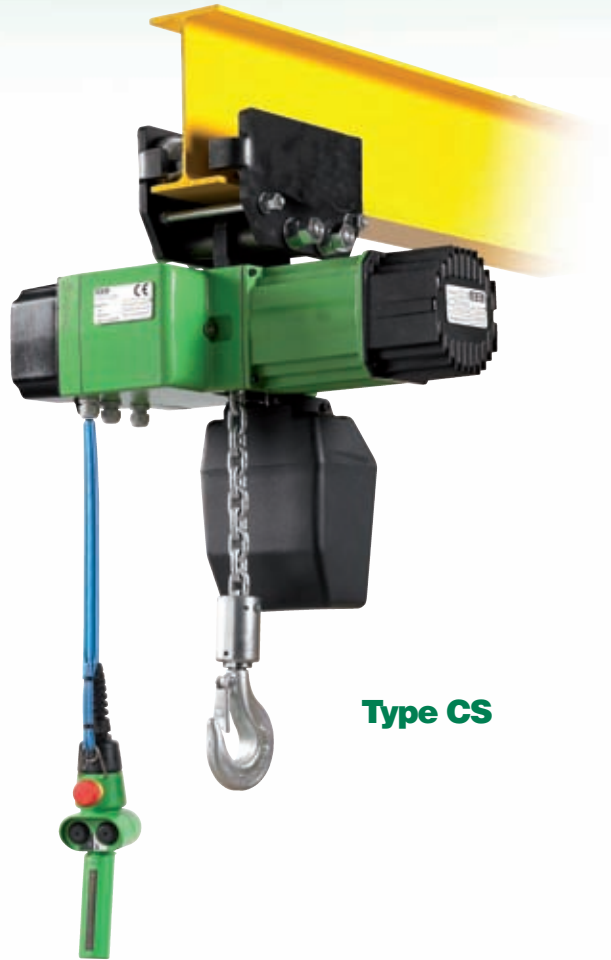

Type CS



Type CE

Low headroom series

electric chain hoists

The low headroom trolleys are used when it is necessary to have the maximum utility height between the floor and the beam. It is important when we have buildings with low height or when it is necessary to enter in compact spaces.



Low headroom = more utility height

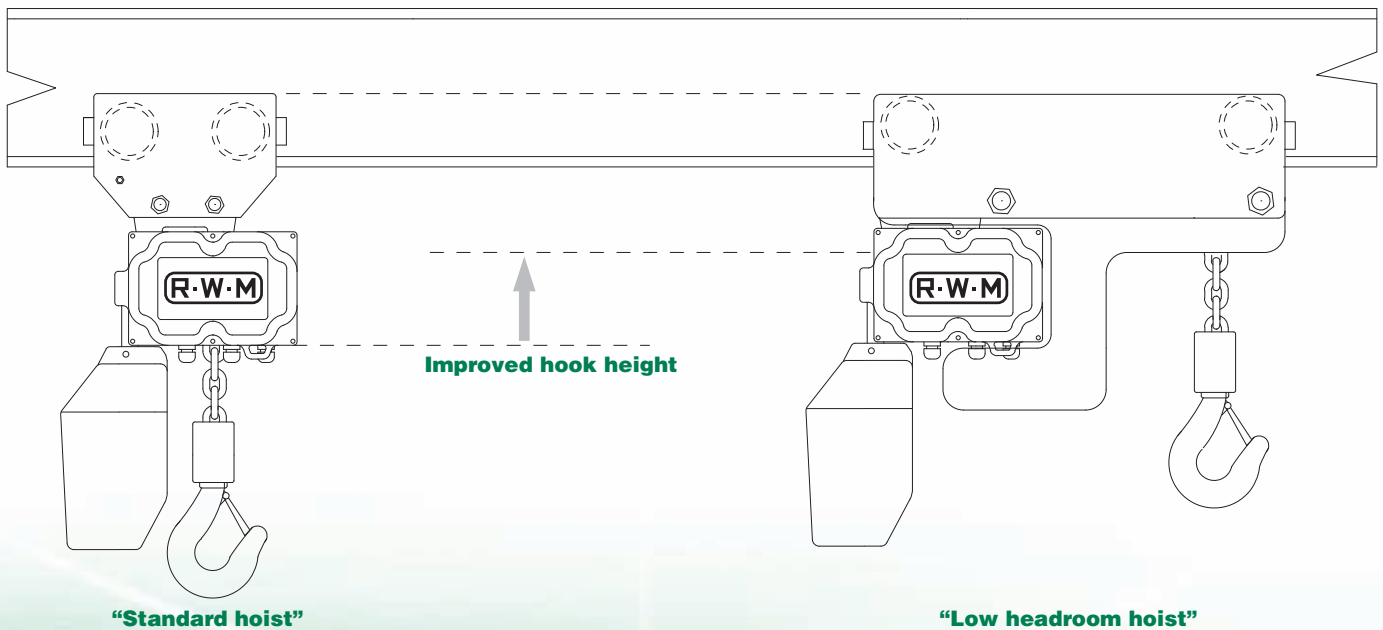

Also in those hoists the principal structure is made from steel plates and electric limit switch to stop the trolley long the beam. The hoist is put to the end of the trolley to reduce the hook respect the beam.

Apply to the W and WR serie, the low headroom trolley is made with one motor with capacity until 1000 kg and with a double motor for capacity from 2000 kg to 5000kg. For special applications those trolleys can be made longer as measure so that the hook can be more free from obstructions.

Type CS-CE

dimensions and technical specifications

Modello	Capacity kg	Speed m/min.	Kw	Pull of chain	Ø chain	A	B	C1	C2	C3	E	F	H		I	L	N	O	P	R		T	V	Weight kg	
													CE	CS						CE	CS			CE	CS
125W5	125	5	0,5	1	4	195	150	130	225	200	230	265	12	8	370	270	240	100	90	65	50	14	65	61	47
125W8	125	8	0,5	1	4	195	150	130	225	200	230	265	12	8	370	270	240	100	90	65	50	14	65	61	47
125W12	125	14	1	1	4	195	150	130	225	200	230	265	12	8	370	270	240	100	90	65	50	14	65	61	47
125W14	125	1-4	0,2-0,5	1	4	195	150	130	225	200	230	265	12	8	370	270	240	100	90	65	50	14	65	61	47
125W28	125	2-8	0,2-0,5	1	4	195	150	130	225	200	230	265	12	8	370	270	240	100	90	65	50	14	65	61	47
250W5	250	5	0,5	1	4	195	150	130	225	200	230	265	12	8	370	270	240	100	90	65	50	14	65	61	47
250W8	250	8	0,8	1	4	195	150	130	225	200	230	265	12	8	370	270	240	100	90	65	50	14	65	63	49
250W14	250	1-4	0,2-0,5	1	4	195	150	130	225	200	230	265	12	8	370	270	240	100	90	65	50	14	65	63	49
250W28	250	2-8	0,25-1	1	4	205	150	130	235	200	230	265	12	8	370	270	240	100	90	65	50	14	65	63	49
500W4	500	4	0,8	1	5	195	150	130	225	200	250	265	12	8	370	270	240	100	90	65	50	14	65	63	49
500W6	500	6	0,8	1	5	195	150	130	225	200	250	265	12	8	370	270	240	100	90	65	50	14	65	63	49
500W8	500	8	1	1	5	205	150	130	235	200	250	265	12	8	370	270	240	100	90	65	50	14	65	66	52
500W14	500	1-4	0,25-1	1	5	205	150	116	235	200	250	265	12	8	370	270	240	100	90	65	50	14	65	66	52
500W28	500	2-8	0,4-1,8	1	7	220	200	116	260	230	330	265	12	12	520	400	295	160	100	70	70	18	94	89	77
1000W4	1000	4	1	1	7	210	200	116	240	230	330	265	12	12	520	400	295	160	100	70	70	18	94	86	74
1000W6	1000	6	1,6	1	7	220	200	116	260	230	330	265	12	12	520	400	295	160	100	70	70	18	94	89	77
1000W14	1000	1-4	0,4-1,8	1	7	220	200	116	260	230	330	265	12	12	520	400	295	160	100	70	70	18	94	89	77
1000W8	1000	8	2	1	10	265	290	210	345	310	350	268	15	15	598	492	436	158	102	80	80	24	94	126	118
1000WR28	1000	2-8	0,5-2	1	10	265	330	210	345	310	350	268	15	15	598	492	436	158	102	80	80	24	94	126	118
1500W4	1500	4	2	1	10	265	290	210	345	310	375	268	15	15	598	492	436	158	102	70	70	24	94	126	118
1500W8	1500	8	3	1	10	350	330	210	320	300	375	268	15	15	817	673	445	255	135	80	80	24	100	138	125
1500WR14	1500	1-4	0,5-2	1	10	265	290	210	345	310	375	268	15	15	598	492	436	158	102	70	70	24	94	126	118
1500WR28	1500	2-8	0,7-3	1	10	350	330	210	350	300	375	268	15	15	817	673	445	255	135	80	80	24	100	138	125
2000W4	2000	4	2	1	10	265	330	210	345	310	375	268	15	15	598	492	436	158	102	70	70	24	94	126	118
2000W8	2000	8	3	1	11	350	330	210	320	330	375	268	15	15	817	673	445	255	135	80	80	24	100	138	125
2000WR14	2000	1-4	0,5-2	1	10	265	290	210	345	310	375	268	15	15	598	492	436	158	102	70	70	24	94	126	118
2000WR28	2000	2-8	0,7-3	1	11	350	330	210	350	330	375	268	15	15	817	673	445	255	135	80	80	24	100	138	125
2500W8	2500	8	3	1	11	350	330	210	320	330	395	310	15	15	817	673	445	255	135	80	80	24	100	148	135
2500WR28	2500	2-8	0,8-3,5	1	11	350	330	210	350	330	395	310	15	15	817	673	445	255	135	80	80	24	100	148	135
3200W4	3200	4	3	2	10	350	330	250	320	300	495	310	15	15	817	673	445	305	85	80	80	24	100	155	137
3200WR14	3200	1-4	0,7-3	2	10	350	330	250	350	330	495	310	15	15	817	673	445	305	85	80	80	24	100	155	137
4000W4	4000	4	3	2	11	350	390	250	320	330	505	310	15	15	817	673	445	305	85	80	80	24	100	158	145
4000WR14	4000	1-4	0,7-3	2	11	350	390	250	350	330	505	310	15	15	817	673	445	305	85	80	80	24	100	158	145
5000W4	5000	4	3	2	11	350	390	250	320	330	505	310	15	15	817	673	445	305	85	80	80	24	100	163	155
5000WR14	5000	1-4	0,8-3,5	2	11	350	390	250	350	330	505	310	15	15	817	673	445	305	85	80	80	24	100	163	155

Type CS-CE dimensions

Low headroom - Type CS

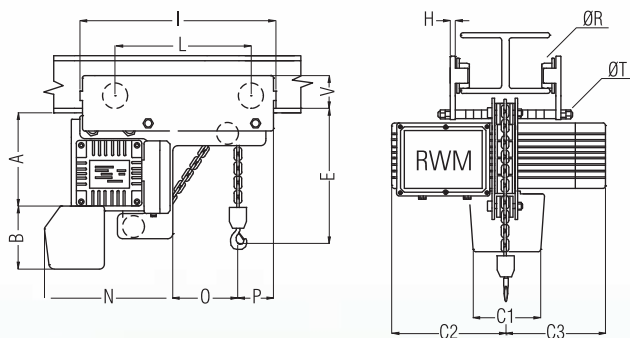

Low headroom - Type CE

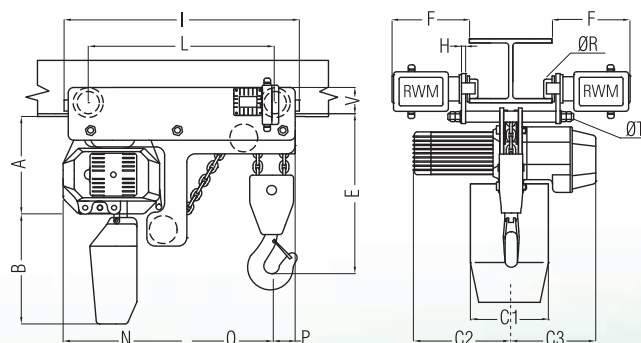

Single phase W series

electric chain hoists



Capacity kg	Speed m/min.	Kw	Pull of chain	Ø chain
125	5	0,5	1	4
125	8	0,5	1	4
250	5	0,5	1	4
250	8	0,8	1	4
500	4	0,8	1	5
500	6	1,5	1	7
1000	4	1,5	1	7

Electric chain hoists 230 V single phase. FEM clas 1 Am R.I. 30%. Available with special tension 110V single phase.

Trolley electrical

RWM power travel trolley's can be fitted to all models of RWM hoists and are used when the load needs to be traversed laterally along a beam. They are fabricated with heavy duty side plates and fitted with anti-drop plates. They have precision machined steel wheels running on permanently sealed for life bearings, braked motors and have travel limits fitted as standard to prevent the hoist being run into the beam end stops, preventing damage.

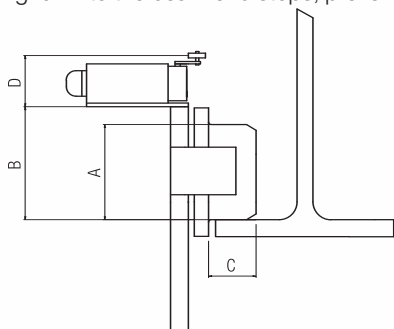

Trolley electrical motors

Direction speed	7 m/min	14 m/min	7/14 m/min
kW da 125 a 2.000	0,2 kW	0,2 kW	0,1/0,2 kW

Motor with conic brake.

kW da 2.500 a 5.000	0,5 kW	0,5 kW	0,2/0,5 kW
------------------------	--------	--------	------------

Motor with electromagnet brake 220VDC.

Minimum radius 900 mm.

Wheels dimensions	A	B	C	D	Beam size minimum
Type 1	50	70	15	//	46
Type 2	65	90	25	60	64
Type 3	70	94	29	63	73
Type 4	80	108	38	57	82

Reference to the R letter of labels.

Chain

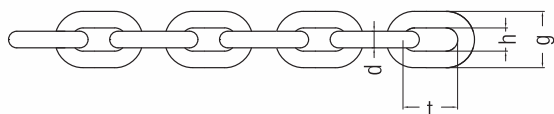

Weight kg/m	d	t	h	g
0,35	4	12	5	13,7
0,54	5	15	6	16,9
1,1	7	22	8,4	23,6
2,2	10	28	12	34
2,7	11	31	13,2	37,4

Calibrated chain EN 818-7.

Hook models

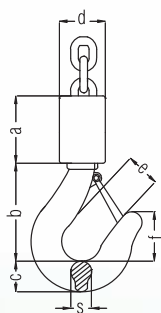

Bottom block T1

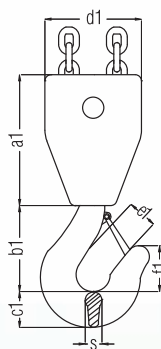

Bottom block T2

Hook n°	Capacity kg	a	b	C	d	e	f	g	s
012	125	62	81	19	50	24	32	30	19
012	250	62	81	19	50	24	32	30	19
025	500	62	88	22	50	28	41	36	20
05	1000	72	110	29	50	34	45	43	29
1	2000	88	135	38	60	40	68	50	38
1	2500	114	135	38	78	40	68	50	38

Bottom block 1/1 DIN 15401.

Hook n°	Capacity kg	a1	b1	c1	d1	e1	f1	g1	s1
1	1500	194	135	38	142	40	68	50	38
1	2000	194	135	38	142	40	68	50	38
1	3000	213	135	45	152	40	68	50	38
1,6	4000	213	145	45	152	45	73	56	45
1,6	5000	213	145	45	152	45	73	56	45

Bottom block 2/1 DIN 15401.

Accessories accessoires



Inverter



Radio remote control



Pendant 2T



Pendant 4T



AGILE pendant

Another accessories

Overload motor protection
INOX chain and hook
Aluminium panel box

Top hook
Hoists runs together
Special voltage



Dynamic business

experience and innovation
quality and performance



A SIMPLE INSTALLATION AND MAINTENANCE

During the development stages, our priorities have been to create a product with an easy installation and maintenance in order to reduce and minimize the relative costs.

SERVICE AND GUARANTEE

The RWM Hoists are built with the highest standards in the development and production. Our confidence in these standard can be reflected by our two year warranty from date of purchase. Furthermore, are national and worldwide network of official RWM distributors assures a presence for any inquiries and service you might require.



Product & Design

MADE IN ITALY

Service and Guarantee

service and guarantee
assistance and guarantee on all our product lines



www.rwmitalia.com
rwm@rwmitalia.com

Lifting solutions

Electric chain hoists



Product & Design

MADE IN ITALY

RWM srl

Via della Tecnica 15 Z.I. - 36034 Molina di Malo (VI) - Italy
Tel. +39 0445 637 002 r.a. - Fax +39 0445 637 019

rwm@rwmitalia.com
www.rwmitalia.com



R-W-M UK Ltd

Unit 16, Junction Lane, Sankey Valley Ind. Est.
WA12 8DN Newton-le-Willows - Merseyside - England
Tel. +44 1925 224 471 - Fax +44 1925 224 471

sales@lifting-engineers.co.uk
www.lifting-engineers.co.uk

The company doesn't assume any responsibility for eventual mistakes or inaccuracies on the content of this depliant and reserves the right to make technical and/or design modifications without notice. It is forbidden the reproduction also partial of plans, drawings, texts and photos. The transgressors will be punished according to the actual laws.