

## HYDRAULIC TABLES

# F

## 500-1.500 kg.

## 700 bar

AUTOMOTIVE

## HYDRAULIC TABLES



### LARZEP advantages

- Model F01571, single lift 1.500 kg capacity and 915 mm high.
- Model F005121, double lift 500 kg capacity and 1.600 mm high.
- A foot pedal is fitted to advance the lifting table quickly to contact the load. The operating handle is then used to lift the load.
- Special lowering valve means that the process is safe and controlled. Overload safety relief valve.
- The frame is in accordance with lifting table security standards.
- "T" operating handle facilitates easier operation.
- The table can be locked at different heights with safety pins.
- Strong steel platform, 1m x 0,5m.
- Heavy duty swivel castors.

**F01571**

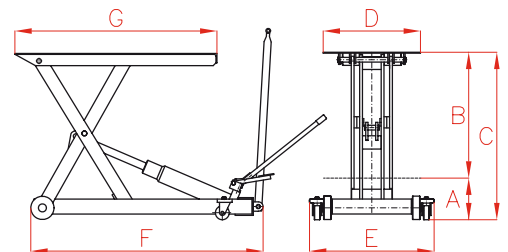

**F005121**

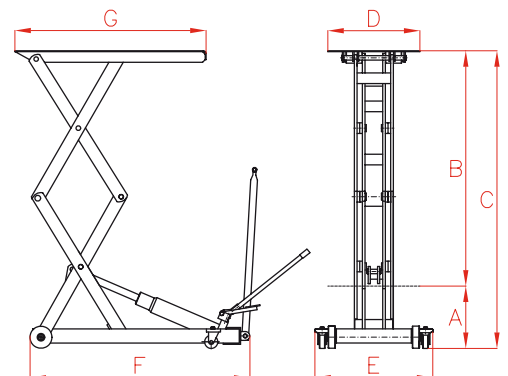

Capacity	Model	A	B	C	D	E	F	G	Weight
kg	LARZEP	mm	mm	mm	mm	mm	mm	mm	kg
500	F005121	270	1.285	1.555	520	666	1.242	1.080	182
1.500	F01571	235	675	910	520	666	1.242	1.080	141