

# HYDRAULIC PUNCHES

## 20 & 35 Ton



HP35

REFER TO PAGE 227 FOR  
PUNCH INFORMATION

- Punch smooth, precise holes in seconds; much faster than drilling.
- Fully portable for construction, maintenance and service applications, or can be mounted on a workbench for production jobs. Has carrying handle for precise locating.
- Rugged, forged steel “C” frame for great strength and durability.
- Dual action, spring loaded stripper holds material during punching operation, strips material from punch on return. Scribe lines on stripper aid in locating the punch (HP 35 only).

- Double Acting prevents binding and speeds retraction (HP20 only).
  - **The PE172** electric/hydraulic pump is an ideal power source.
- No. HP35** – Punch only, includes metal case and die change tools. Wt., 42.5 lbs.
- No. HP35S** – Punch with punches and dies. Includes HP35 punch, metal case and 250459 punch/die set. Wt., 44 lbs.
- No. HP35P** – Punch set with pump. Same as HP35SP but does not include punch/die set. Wt., 86.3 lbs. NOTE: Available in 220 volt, 50 Hz. Order with suffix “-220”.

- No. HP35SP** – Punch set with pump. Includes HP35 punch, PE172 electric/hydraulic pump, 9756 hose, 9798 hose half coupler, 250459 punch/die set, metal case. Wt., 87.8 lbs. NOTE: 220 volt, 50 Hz. Order with suffix “-220”.
- No. 250459** – Punch/die set for round holes. Includes one each: PD437  $\frac{7}{16}$ " punch/die, PD562  $\frac{9}{16}$ " punch/die, PD688  $\frac{11}{16}$ " punch/die, PD812  $\frac{13}{16}$ " punch/die. Wt., 1.5 lbs.

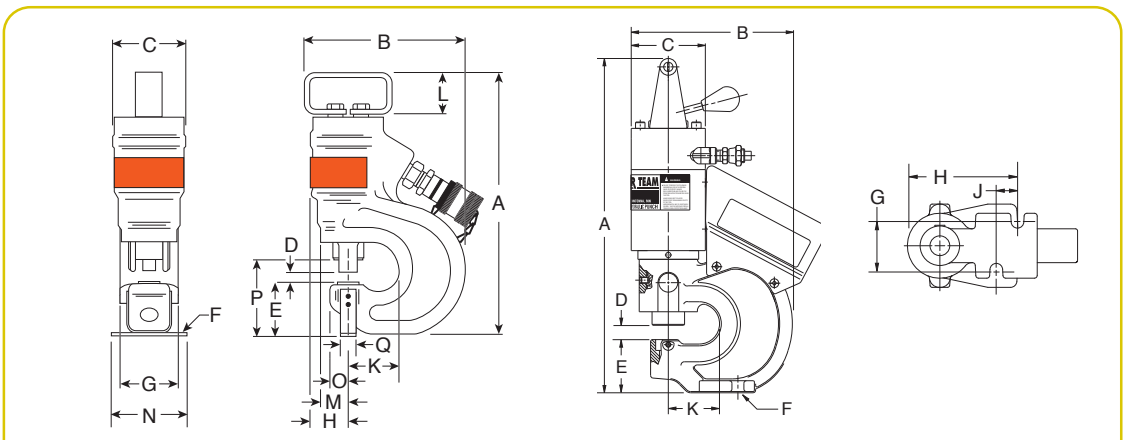

Cap.	Order Number	Max. Oper. Press.	Max. Oil Cap.	Max. Material Thickness	Mtng. Holes																
					A (in.)	B (in.)	C (in.)	D (in.)	E (in.)	F (in.)	G (in.)	H (in.)	J (in.)	K (in.)	L (in.)	M (in.)	N (in.)	O (in.)	P (in.)	Q (in.)	
20	HP20	10,000 psi	3.9 cu.in.	$\frac{1}{2}$	$16\frac{1}{2}$	$7\frac{61}{64}$	$3\frac{21}{32}$	$\frac{5}{8}$	$2\frac{19}{32}$	$\frac{9}{16}$	$2\frac{1}{8}$	$4\frac{7}{8}$	$1\frac{5}{16}$	$2\frac{1}{4}$	—	—	—	—	—	—	
35	HP35	10,000 psi	4.6 cu.in.	$\frac{1}{2}$	$13\frac{3}{4}$	9	$3\frac{3}{4}$	$\frac{9}{16}$	$2\frac{7}{8}$	$\frac{1}{4}$	3	$1\frac{13}{16}$	—	$2\frac{13}{16}$	$2\frac{1}{4}$	$1\frac{1}{2}$	$3\frac{1}{2}$	$\frac{7}{8}$	4	$\frac{3}{4}$	

**No. HP20** – Basic punch. Wt., 33 lbs.

**No. HP20S** – Punch frame with cylinder, valve, handle, two coupling nuts, plus five punch and die sets in 1/4", 5/16", 3/8", 7/16", and 17/32" dia. Wt., 35 lbs.

**No. HP20SP\*** – Complete punch set with PE102A pump (115V, 50/60 Hz), 9682 nipple, two 9792 female couplers and two 9793 male couplers. Also includes two 9758 10' hoses, 9680 coupling, and same punch and die sets as in HP20S (above). Tool is completely assembled and pre-filled with oil. In storage box. Wt., 83 lbs.



HP20



**Punch Set HP20SP**  
Includes the PE102A pump, hoses, couplers, punch and die sets in sizes 1/4", 5/16", 3/8", 7/16", and 17/32" diameter, with storage box.

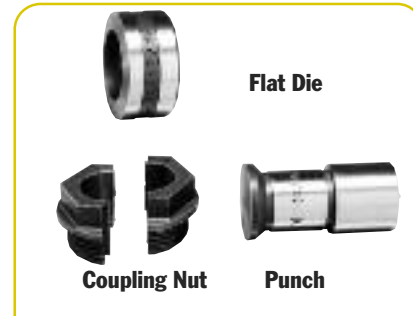

Flat Die

Coupling Nut

Punch

**PUNCH/DIE SETS FOR HP20 & HP35 HYDRAULIC PUNCHES**

For use with HP20 Hydraulic Punch

For use with HP35 Hyd. Punch

Punch Size (in.)	Punch Style	Punch No.	Flat Die No.	Bevel Die No.	Coupling Nut No.	Punch/w Flat Die Set	Punch/w Bevel Die Set	Punch Size (in.)	INCHES		MM	
									Hole Dia.	Bolt	Hole Dia.	Bolt
1/4	Round	251970	251983	—	252001	—	—	1/4	1/4	#10	6.3	—
5/16		251971	251984	—	252001	PD313	—	5/16	5/16	1/4	7.9	—
3/8		251972	251985	251996	252001	PD375	PD375B	3/8	3/8	5/16	9.5	M8
7/16		251973	251986	251997	252001	PD437	PD437B	7/16	7/16	3/8	11.2	M10
17/32		251974	251987	251998	252001	PD531	PD531B	17/32	17/32	7/16	13.5	M12
9/16		251975	251988	251999	252001	PD562	PD562B	9/16	9/16	1/2	14.3	—
11/16		251976	251989	—	252001	PD688	—	11/16	11/16	5/8	17.5	M16
25/32		251977	251990	—	252002	PD781	—	25/32	25/32	—	19.8	M18
13/16		251978	251991	—	252002	PD812	—	13/16	13/16	3/4	20.6	—
1/2	Square	251979	251992	—	252002	—	—	—	—	—	—	—
17/32		251980	251993	—	252002	—	—	—	—	—	—	—
1/4 X 3/4	Obround	251981	251994	—	252002	—	—	—	—	—	—	—
3/8 X 3/4		251982	251995	—	252002	—	—	—	—	—	—	—

**TYPICAL 20 TON STYLE TOOLING**

HYDRAULIC TOOLS



**ACCESSORIES FOR HP20 HYDRAULIC PUNCH**

No. HP20FS – Optional foot switch mounted in foot switch guard. Supplied with 10 foot cord and male remote connector. Wt., 2 lbs.

No. HP20HS – Optional handswitch. Supplied with 10 foot cord and male remote connector. Wt., 2 lbs.

No. 252000 – Optional coupling nut wrench. Makes punch/die changes easier without “rounding-off” coupling nuts. Wt., 0.5 lbs.