

C14-HHT / 14-HHT HAND HYDRAULIC CRIMPING TOOL

INTRODUCTION



The 14-HHT Series Crimping tool is a two-speed crimper designed for installing aluminum and copper connectors on stranded electrical conductors.

The two-speed pump provides a fast approach to the connector with minimal effort. The piston is retracted by lifting the handle slightly, twisting clockwise until it stops and then making a short pumping stroke

Note that the operator need not remove his hands from the tool for this operation.

The C-Head of the compressor can be rotated 360 degrees providing accessibility to awkward working positions.



WARNING

THE 14-HHT IS NOT TO BE USED FOR "HOT LINE" WORK

SPECIFICATIONS

PUMP SECTION:

Injector stroke: .56 inch (1.42 cm)
Low pressure pump output:
.441 cu. in. per stroke (.007 liter per stroke)
High pressure pump output:
.034 cu. in. per stroke (.0005 liter per stroke)
Opening of low pressure unloading valve:
500 psi (35 BAR)
Opening of low pressure relief valve:
25 psi (2 BAR)
Opening of high pressure relief valve:
10,000 to 10,400 psi (690 to 724 BAR)
Handle effort:
4.2 lbs. per 1,000 psi (1.90 kg per 69 BAR)
Reservoir capacity: 8.5 cu. in. (.14 liter)
Oil type: Amoco Rykon MV

TOOL SECTION:

Piston diameter:
1.88 inches (4.77 cm)
Stroke:
1.58 in. (4.01 cm)
Crimping force:
13.9 U.S. tons at 10,000 psi (12.6 metric tons
at 690 BAR)
Head rotation: 360 degrees

OVERALL DIMENSIONS:

Size:
3.1 x 8.3 x 23.1 inches long
(7.88 x 21.2 x 58.6 cm long)

TOTAL WEIGHT:

17.4 pounds with oil
(7.9 kg with oil)

CRIMPING CAPACITY:

No. 8 thru 750 MCM aluminum and
copper connectors
(6.37 sq. mm thru 379.5 sq. mm)

IMPORTANT SAFETY INFORMATION



This is the safety alert symbol.

It is used to alert you to potential personal injury hazards. Obey all safety messages that follow this symbol to avoid possible injury or death



DANGER

Denotes an imminently hazardous situation which, if not avoided, will result in death or serious injury.



WARNING

Denotes a potentially hazardous situation which, if not avoided, could result in death or serious injury.



CAUTION

Denotes a potentially hazardous situation which, if not avoided, may result in minor or moderate injury.

CAUTION

Caution used without the safety alert symbol indicates a potentially hazardous situation which, if not avoided, may result in property damage.

IMPORTANT

Denotes an operating or service procedure or condition considered essential for expedient and efficient operation and service.



WARNING To help prevent personal injury,



- Always wear eye protection whenever operating hydraulic equipment.



- Always wear hearing protection as required.

- Operation, repair, or maintenance of hydraulic equipment should be performed by a qualified person who understands the proper function of hydraulic equipment per local directives and standards.
- Hydraulic equipment must be assembled correctly and then checked for proper function before use. Use hydraulic components of the same hydraulic pressure ratings. An appropriate hydraulic pressure gauge is recommended to monitor pressure.



- Never place your hands or other body parts near a hydraulic fluid leak.
- Never use your hands or other body parts to check for a possible leak.

High pressure fluid can be injected under your skin causing serious injury and/or infection.



- Exercise caution to avoid the risk of fire. An incomplete crimp can cause a fire. Use proper die, connector and cable. Improper combinations can result in an incomplete crimp.



- DO NOT USE FOR HOT LINE WORK
- This tool is not insulated. When using this unit near energized electrical lines, use proper personal protective equipment.



CAUTION

- This tool is intended for two-handed operation. Maintain a firm grip on both handles during operation. Using this tool in any other manner can result in injury or equipment damage.
- Do not advance Ram without Dies inserted.

IMPORTANT

- Properly dispose of all fluids, components, and assemblies at the end of their useful life.
- Hydraulic fluid should be compatible with all hydraulic components.



WARNING



It is the operators responsibility to read and understand the following safety statements,

- Only qualified operators should install, operate, adjust, maintain, clean, repair, or transport this machinery.
- Inspect tool before use. Replace any worn or damaged parts. Failure to observe these warnings can result in severe injury or death.



WARNING



Keep hands away from the crimping tool head when crimping.

OPERATING INSTRUCTIONS

CAUTION DO NOT OPERATE THE COMPRESSOR WITHOUT DIES.

Installing Die Set

1. Select the proper dies that corresponds to the size and type of connector to be crimped.
2. Push die release button on the C-head and slide die half into the jaw. Release the button and slide the die half until the retainer snaps and locks die into place.
3. Install remaining die half in same manner. Note: Piston must be partially extended to gain access to bottom die release button

Making Crimping

1. Prepare the cable by stripping off the appropriate amount of insulation.
2. Select a connector that corresponds to the conductor and the application.
3. Place connector to be crimped between die halves.
4. To crimp, pump handle. After dies touch, continue pumping until an audible popping sound is heard. A slight reduction of handle effort will be felt, indicating crimp is complete.
5. To retract piston, slightly spread handles apart, twist pump lever clockwise until it stops, firmly push the lever down to depress the pressure release plunger.

Note: To stop the ram from retracting completely, raise the pump handle. This speeds the crimping process when multiple crimps are required.

IMPORTANT

The majority of service troubles are caused by dirt collecting about the tool or in the oil system. Keep the tool clean and prevent foreign matter from entering the compressor while filling the reservoir. Lubricate all moving parts and keep the C-head stop screw, ram guide screw, and reservoir handle stop screw tightened.

FILLING RESERVOIR To add or replace oil in the compressor, retract the ram completely. Loosen the reservoir handle stop screw and remove the handle. Remove the reservoir plug and O-ring seal. Pull the stem of the reservoir bladder out as far as possible. Add oil until it fills the stem. See "Compatible Hydraulic Fluids" Section

CAUTION DO NOT USE BRAKE FLUID OF ANY KIND.

PERIODIC MAINTENANCE

Occasionally lubricate release button assemblies. Use of a molybdenum disulfide grease is recommended. Pivot pin and lifter pin assemblies should also be cleaned and lubricated occasionally to prevent sticking.

OIL LEAKAGE

A small amount of weepage from the piston and pump seals is normal and required to keep moving parts lubricated. Excessive leakages indicate a need for seal replacements and should be done only by an authorized service center.

REPLACING HYDRAULIC SEALS

Maintenance and repair of this tool should be provided with the same reasonable care given other fine equipment. Service should be performed by adequately trained personnel in repair shops under clean conditions. For those owners having adequately staffed repair facilities, a hydraulic seal replacement kit No. 4-1066 containing O-rings, gaskets, etc., needed for one complete replacement of hydraulic seals in the compressor. In addition, a repair kit No. 4-1065 (pump mechanism) is available. Include compressor serial number when ordering all parts.

To replace the seals it is necessary to separate the C-head and piston assemblies from the cylinder. Remove both die halves. Removing the quick coupler drains the oil and aids in dis-assembly. Remove screw and washer to unlock cylinder.

Unscrew the C-head and the piston will also rotate. After nine complete turns the piston spring rod is unthreaded from within the cylinder and the piston guide arrangement should be removed. Further rotation will separate the C-head from the cylinder. Pull the piston from the cylinder. All seals and rings are now accessible.

Reassemble with clean parts lubricated with the same grade of oil used in the remote pump. The steel piston washer and leather wiper are installed on the outside of the piston with the steel washer next to the shoulder on the piston.

Sheet No. 2 of 7

Rev 1 Date: 13 June 2005

REPLACING HYDRAULIC SEALS (continued)

Insert piston into cylinder, rotate assembly until hand tight. Backoff one-half turn to permit the piston wipers to center themselves in the C-head bore. Thread the C-head onto the cylinder until the bottom of the die groove in piston is flush at a corresponding point on the C-head. Continue rotation until the key slots align. At this attitude, top of piston should not have entered C-head opening and a die-half can be inserted in piston groove.

Reassemble the piston guide arrangement with Loctite on screw threads.

Invert the tool and fill the cylinder with oil. Bleed air from cylinder by rocking tool back and forth. Assemble 3/8 inch female quick coupler.

TROUBLE SHOOTING

If the ram will not extend completely, it will generally be found that there is an insufficient amount of oil in the crimper's hydraulic system. This trouble can also be caused by faulty pump plunger packing or release valve packing by the pressure release valve being stuck open, or by foreign matter preventing the release valve balls from seating properly. Faulty packing will usually be detected by excess oil leakage around the pump plunger. Foreign matter can frequently be flushed from a valve seat by pumping very rapidly with abrupt strokes.

If the dies will not close and pumping is difficult, check the die number to make certain the proper size die is being used on the accessory. If the dies will not close and pumping becomes easier, usually additional oil is needed in the crimper. There is also the possibility that the pressure release valve balls are not seating properly.

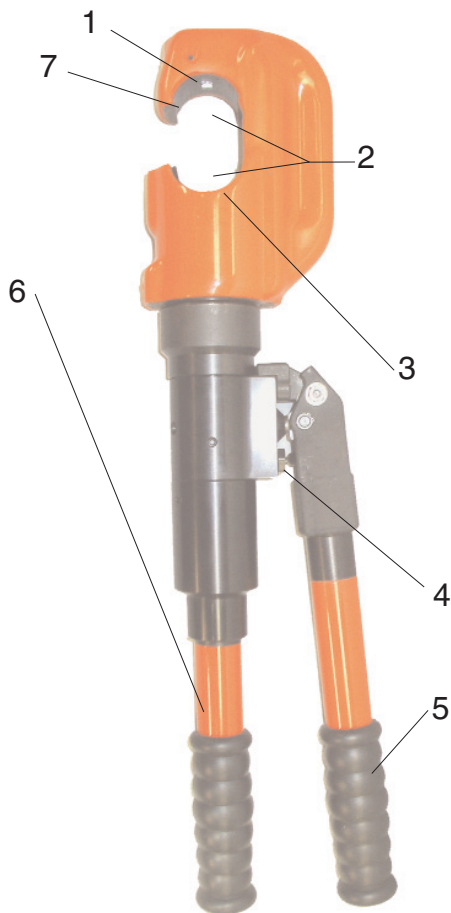

Illustration

- | | |
|-----------------------|---------------------|
| 1. Die Release Button | Plunger |
| 2. Dies | 5. Lever Handle |
| 3. Die Release Button | 6. Reservoir Handle |
| 4. Pressure Release | 7. C-Head |

If the ram will not retract completely, it will generally be found that there is too much oil in the crimper. Drain enough to permit complete retraction. If the ram will not retract and the oil reservoir is not full, the ram is likely being held by a deformed washer.

A small amount of leakage is desirable around the ram; pump plunger, and pressure release valve plunger to lubricate these parts. If enough leakage occurs to cause the oil to run, the packing should be replaced.

If the dies do not lock in position, the action of the retaining pins is probably restricted by dirt. Clean and oil these parts.

If it is difficult to unlock the die-haves, the die release buttons should be lubricated. The die retaining pin set screw in the C-head above the die release button is staked in position. To further tighten this screw will make it difficult or impossible to release the die.

COMPATIBLE HYDRAULIC FLUIDS:

The use of Amoco Rykon MV oil is recommended.

Compatible fluids include:

Mobil DTE 13	Mobil ATF 220
Shell Tellus 32	Arco Dexron III
Citgo AW32	Citgo Dexron III

Other fluids also may be used if they meet or exceed the following specifications:

Viscosity: 180 SSU at 100 degree F.

Flash Point: 350 degree F

Pour Point: -50 degree F:

INSTRUCTIONS FOR CONVERSION TO 14-HTR



14-HHT TOOL

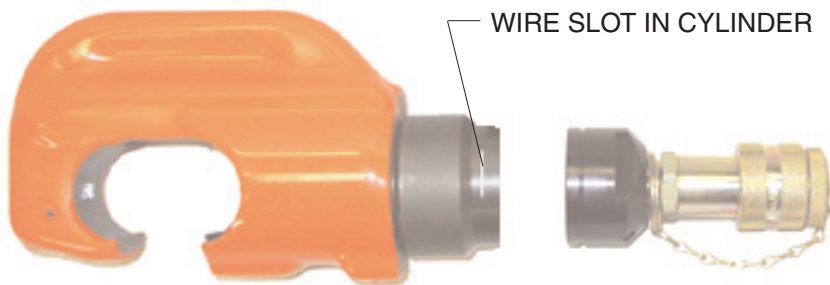

C-HEAD ASSEMBLY
(PART NUMBER 3000092)

REMOTE END CAP ASSEMBLY
(PART NUMBER 4-0765)



CONVERSION ASSEMBLY
(PART NUMBER 4-0766)

- 1-RETAINING WIRE
- 1-WRAP AROUND DECAL

1. Fully retract tool ram and make sure all pressure has dissipated.
2. Place tool in a vise with handles pointing upward. Remove adhesive label covering slot in cylinder.
3. Pry hooked end of retaining wire out of slot in cylinder.
4. Holding hooked end of wire with pliers, rotate cylinder to force retaining wire out of groove and through slot. Discard wire.
5. Carefully separate pump assembly from cylinder assembly, holding discharge spring in place.
6. Apply lubricant to groove in end cap of remote tool and to retaining wire.
7. Insert end cap into back end of cylinder assembly. Rotate cylinder assembly until hole in end cap appears in slot in cylinder.
8. Place hooked end of new wire from conversion kit into hole in end cap. Align free length of wire along slot in cylinder. Rotate cylinder assembly in opposite direction to feed wire through slot and into groove.
9. When wire is fully engaged, hooked end will snap out of hole in end cap to permit full head rotation. Wedge spring pin in slot in cylinder, allowing wire to move freely beneath. Seal slot with new adhesive label.
10. Purge air from remote tool and pump system using normal fill and bleed procedures.

PARTS LIST

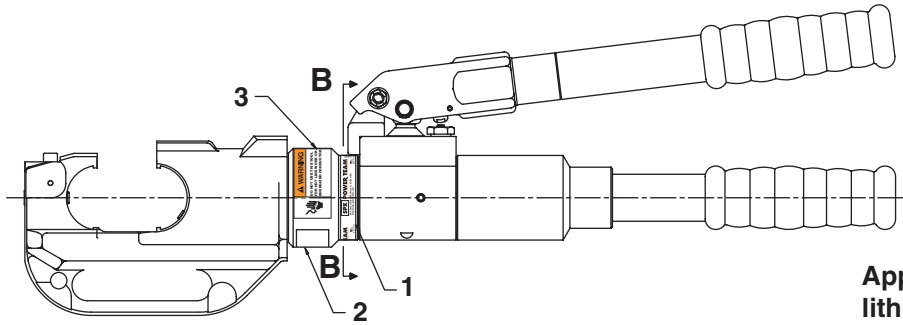

Apply "White Lube" lithium grease (213083) to wire and groove before assembling

C14-HHT / 14-HHT

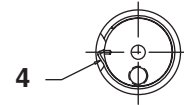

Item No.	Part No.	No. Req'd	Description
----------	----------	-----------	-------------

Item No.	Part No.	No. Req'd	Description
----------	----------	-----------	-------------

1	1000053	1	Decal, (Tradename Power Team)
2	420691	1	Decal, (Product Blank)
3	1000055	1	Decal, (Warning & Caution)
4	3-9678	1	Retaining Wire

ITEM NOT SHOWN			
	2000147	1	Bag, Nylon Carrying (2.5' x 6' x 22')
	4-0826-BK	1	Case, Carrying

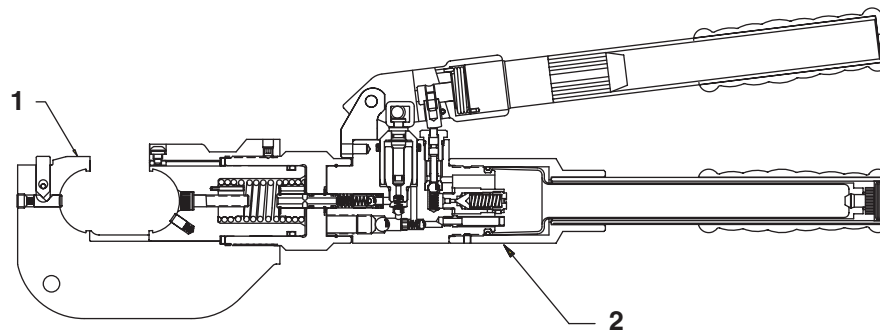
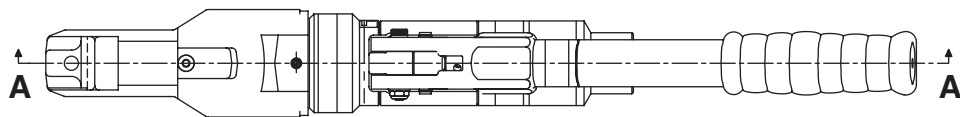

SECTION A-A

C14-HHT / 14-HHT

Item No.	Part No.	No. Req'd	Description
----------	----------	-----------	-------------

Item No.	Part No.	No. Req'd	Description
----------	----------	-----------	-------------

1	3000092	1	C-Head/Ram/Cylinder Assembly
---	---------	---	------------------------------

2	3000089	1	Pump, Mech. Sub Assembly
---	---------	---	--------------------------

PARTS LIST

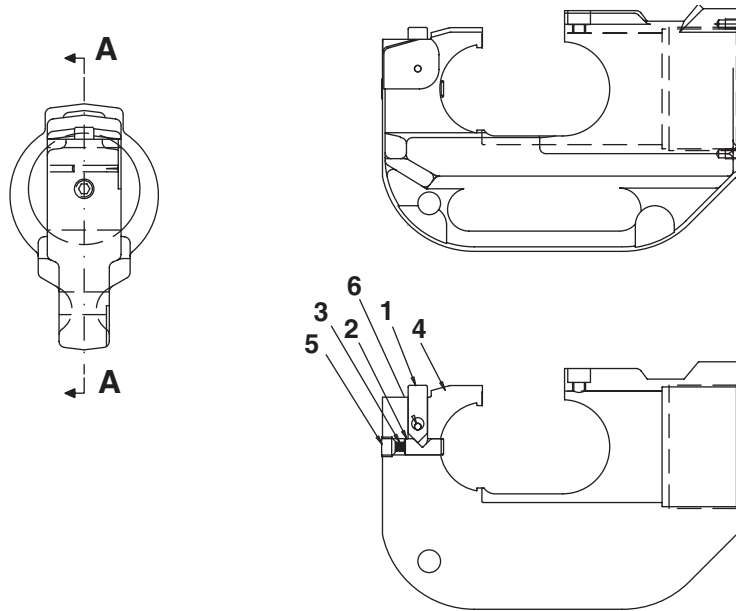

SECTION A-A

C-HEAD ASSEMBLY 3000091 & 3-8368

Item No.	Part No.	No. Req'd	Description
1	3-1237	1	Shaft
2	3-1238	1	Pin, Retainer
3	3-1239	1	Spring, Compression
4	2000154	1	C-Head (coated)
4	3-8341	1	C-Head

Item No.	Part No.	No. Req'd	Description
5	5-0662	1	Screw, Set
6	5-1265	1	Pin, Drive

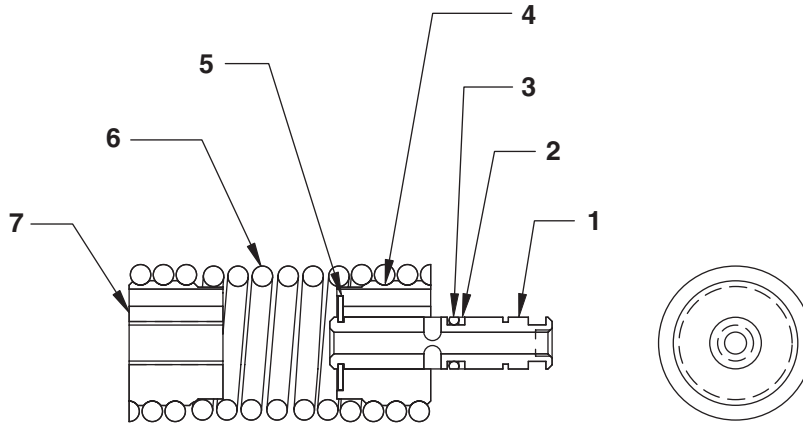

SPRING ASSEMBLY 4-1324

Item No.	Part No.	No. Req'd	Description
1	4-1322	1	Tube, Transfer
2	5-3245	1	Ring, Back-Up
3	10266	1	O-Ring
4	3-9683	1	Retaining, Swivel

Item No.	Part No.	No. Req'd	Description
5	11032	1	Ring, Retaining
6	3-9681	1	Spring, Tension
7	3-9682	1	Retainer, Threaded

PARTS LIST

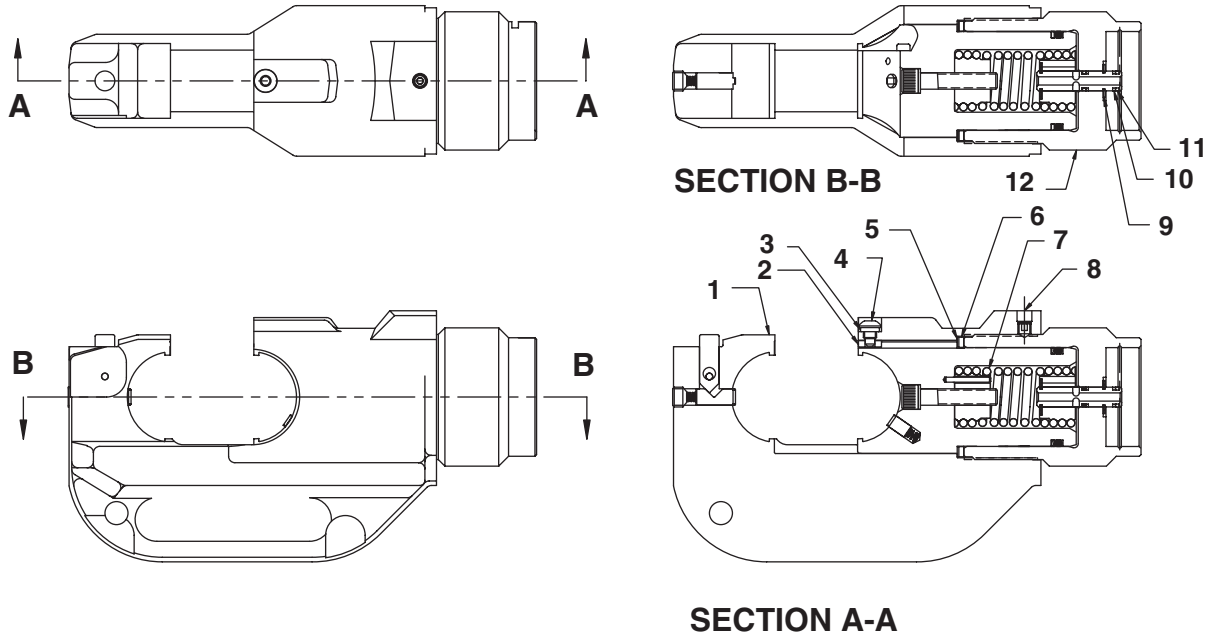

C-HEAD/RAM CYLINDER ASSEMBLY 3000092 & 4-0715

Item No.	Part No.	No. Req'd	Description	Item No.	Part No.	No. Req'd	Description
1	3000091	1	C-Head Assembly (Coated)	7	4-0717	1	Ram Sub-Assembly
	3-8368	1	C-Head Assembly	8	5-0152	1	Screw, Socket Set
2	3-1204	1	Key	9	11032	1	Ring, Retaining
3	5-1258	1	Lock Washer	10	5-3245	1	O-Ring
4	3-1203	1	Screw	11	10266	1	O-Ring
5	3-8390	1	Washer, Piston (Ref.)	12	4-0716	1	Cylinder
6	3-8391	1	Wiper, Piston (Ref.)				

Press Bushings in flush with inside surface using arbor press.

Insert Spacer before pressing in Bushings.

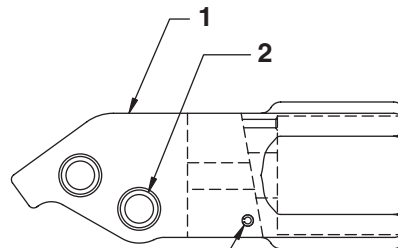
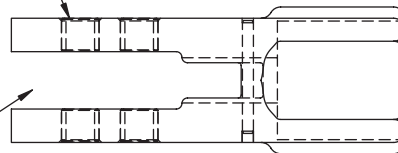

Slot in pin must be facing front (9 o'clock in this view)

LEVER HEAD SUB-ASSEMBLY 3-8352

Item No.	Part No.	No. Req'd	Description	Item No.	Part No.	No. Req'd	Description
1	3-8348	1	Head, Lever	3	11566	1	Pin, Spring
2	3-4838	4	Bushing				

PARTS LIST

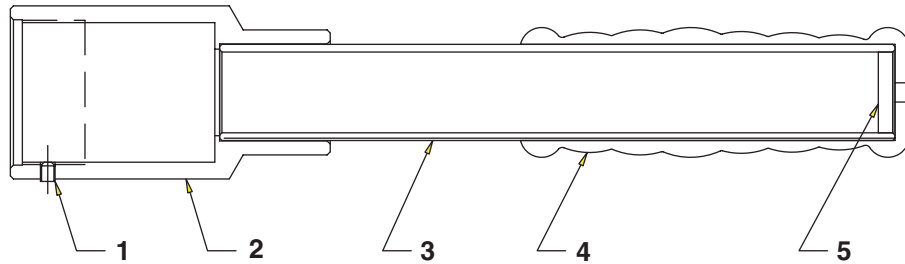
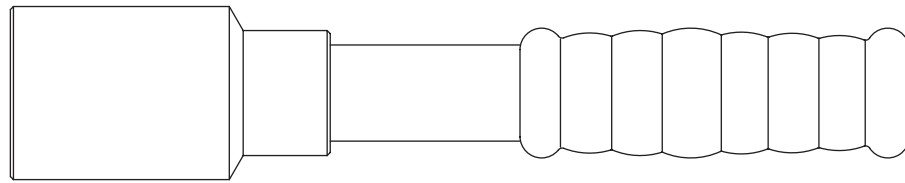

SECTION VIEW

RESERVOIR HANDLE ASSEMBLY 3000087

Item No.	Part No.	No. Req'd	Description	Item No.	Part No.	No. Req'd	Description
1	5-0425	1	Screw, Set	4	3-5056	1	Grip, Handle
2	3000086	1	Handle/Adapter Sub-Assembly	5	4-0413	1	Plug, Felt
3	5-2377	.1 oz	Cement				

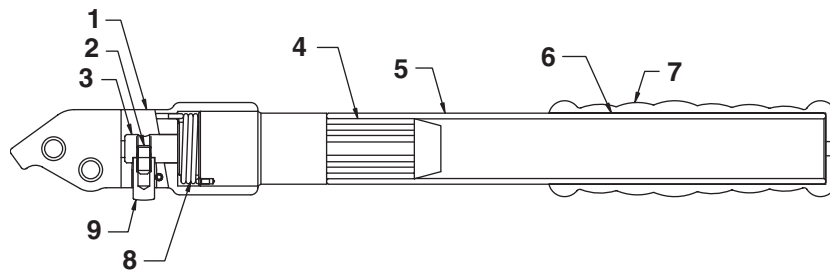
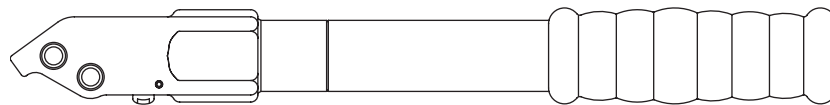

LEVER ASSEMBLY 3000088

Item No.	Part No.	No. Req'd	Description	Item No.	Part No.	No. Req'd	Description
1	3-8352	1	Head Sub-Assembly, Lever	6	5-2377	.1 oz.	Cement
2	10138	1	Screw, Set	7	3-5056	1	Grip, Handle
3	3-8349	1	Shaft, Release	8	3-8351	1	Spring, Torsion
4	5-2538	.1 oz.	Adhesive	9	3-8350	1	Pin, Striker
5	2000148	1	Handle				

PARTS LIST

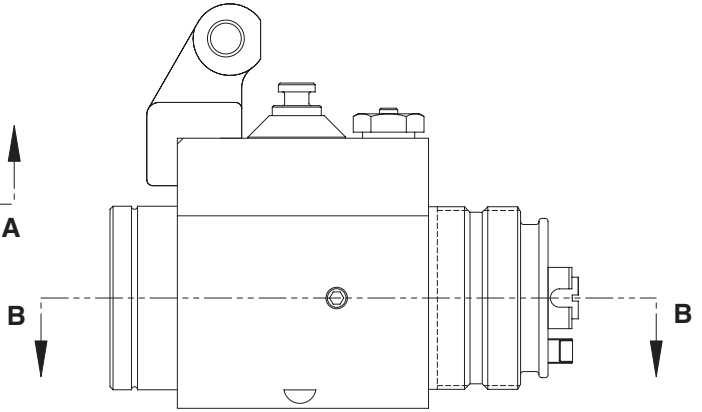
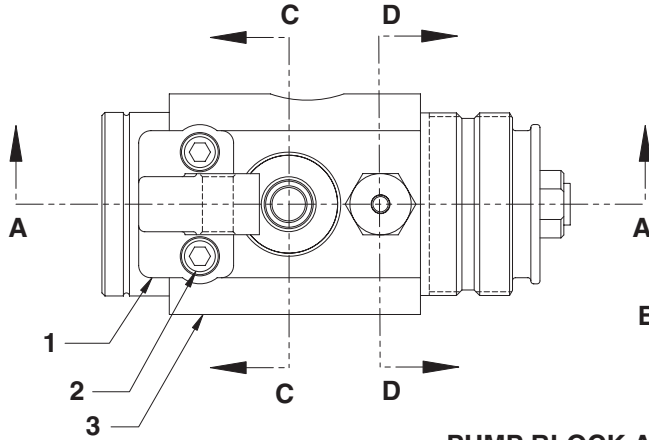

PUMP BLOCK ASSEMBLY 4-0640

Item No.	Part No.	No. Req'd	Description
1	3-5134	1	Bracket, Fulcrum
2	10008	2	Screw, SHC

Item No.	Part No.	No. Req'd	Description
3	3-9676	1	Block, Pump

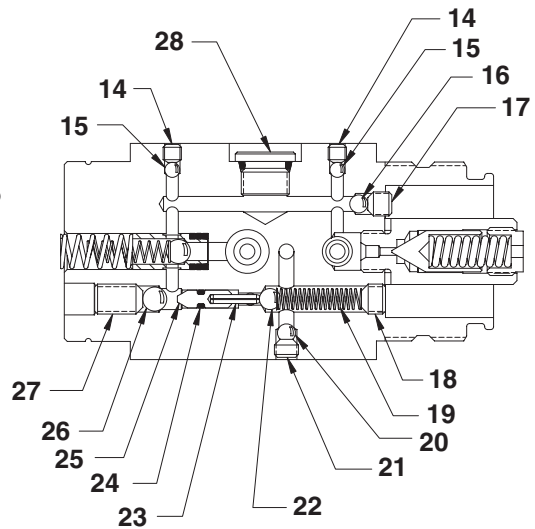
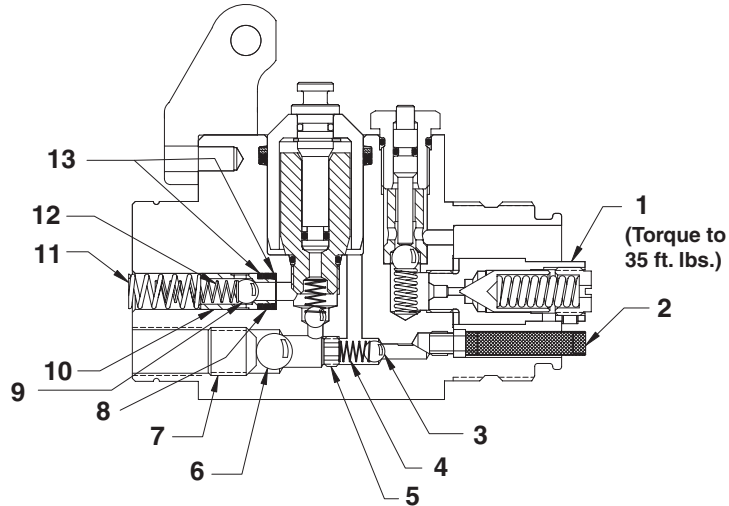

SECTION A-A

PUMP BLOCK ASSEMBLY 4-0640

SECTION B-B

Item No.	Part No.	No. Req'd	Description
1	3-2716	1	Valve, H.P. Relief
2	3-7629	1	Filter, Intake
3	10374	1	Ball
4	3-5129	1	Spring, Compression
5	5-0873	1	Screw, Hollow
6	10378	1	Ball
7	5-2551	1	Screw, Set
8	10266	1	O-Ring
9	10375	1	Ball
10	4-0495	1	Insert, H.P. Discharge
11	5-2923	1	Spring, Compression
12	5-3674	1	Spring, Compression
13	12184	1	Ring, Back-Up
14	5-0341	2	Screw, Set
15	10419	2	Ball

Item No.	Part No.	No. Req'd	Description
16	12223	1	Ball
17	5-0343	1	Screw, Set
18	5-0659	1	Screw, Set
19	5-1992	1	Spring, Compression
20	12223	1	Ball
21	5-3399	1	Screw, Set
22	10374	1	Ball
23	5-0121	1	Pin, Spring
24	5-3261	1	O-Ring
25	3-7474	1	Plunger, L.P.
26	10375	1	Ball
27	5-0649	1	Screw, Set
28	5-3855	1	Plug, Seal

PARTS LIST

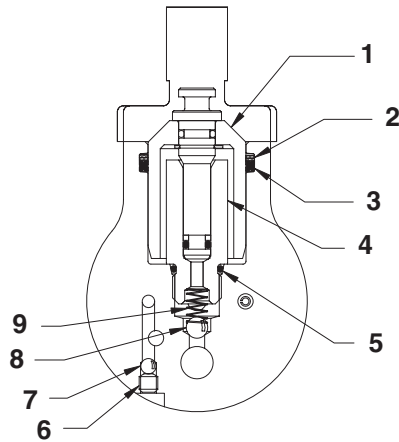

SECTION C-C

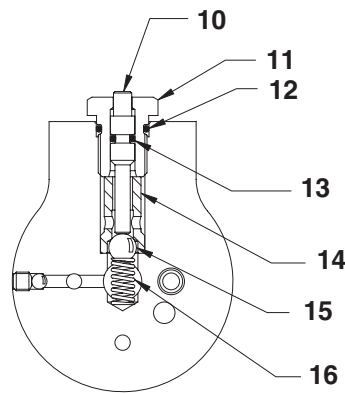

SECTION D-D

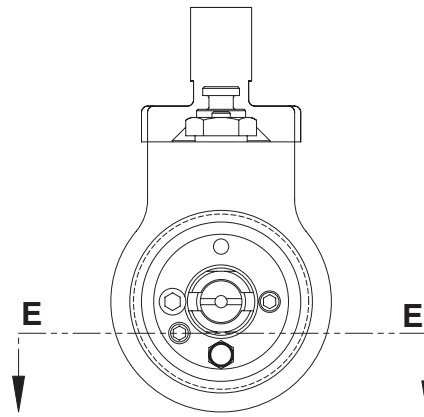

SECTION E-E

PUMP BLOCK ASSEMBLY 4-0640

Item No.	Part No.	No. Req'd	Description
1	4-0642	1	Injector Assembly
2	5-0049	1	Ring, Back-Up
3	5-3341	1	Quad-Ring
4	4-0641	1	Housing, H.P.
5	12098	2	O-Ring
6	5-0341	1	Screw, Set
7	10419	1	Ball
8	10374	1	Ball
9	3-5129	1	Spring, Compression
10	3-5011	1	Plunger, Release

Item No.	Part No.	No. Req'd	Description
11	3-5010	1	Screw
12	12098	2	O-Ring
13	10264	1	O-Ring
14	3-5009	1	Insert
15	10423	1	Ball
16	5-3000	1	Spring, Compression
17	12223	1	Ball
18	5-3260	1	Spring, Compression
19	5-2062	1	Screw, Set

PARTS LIST

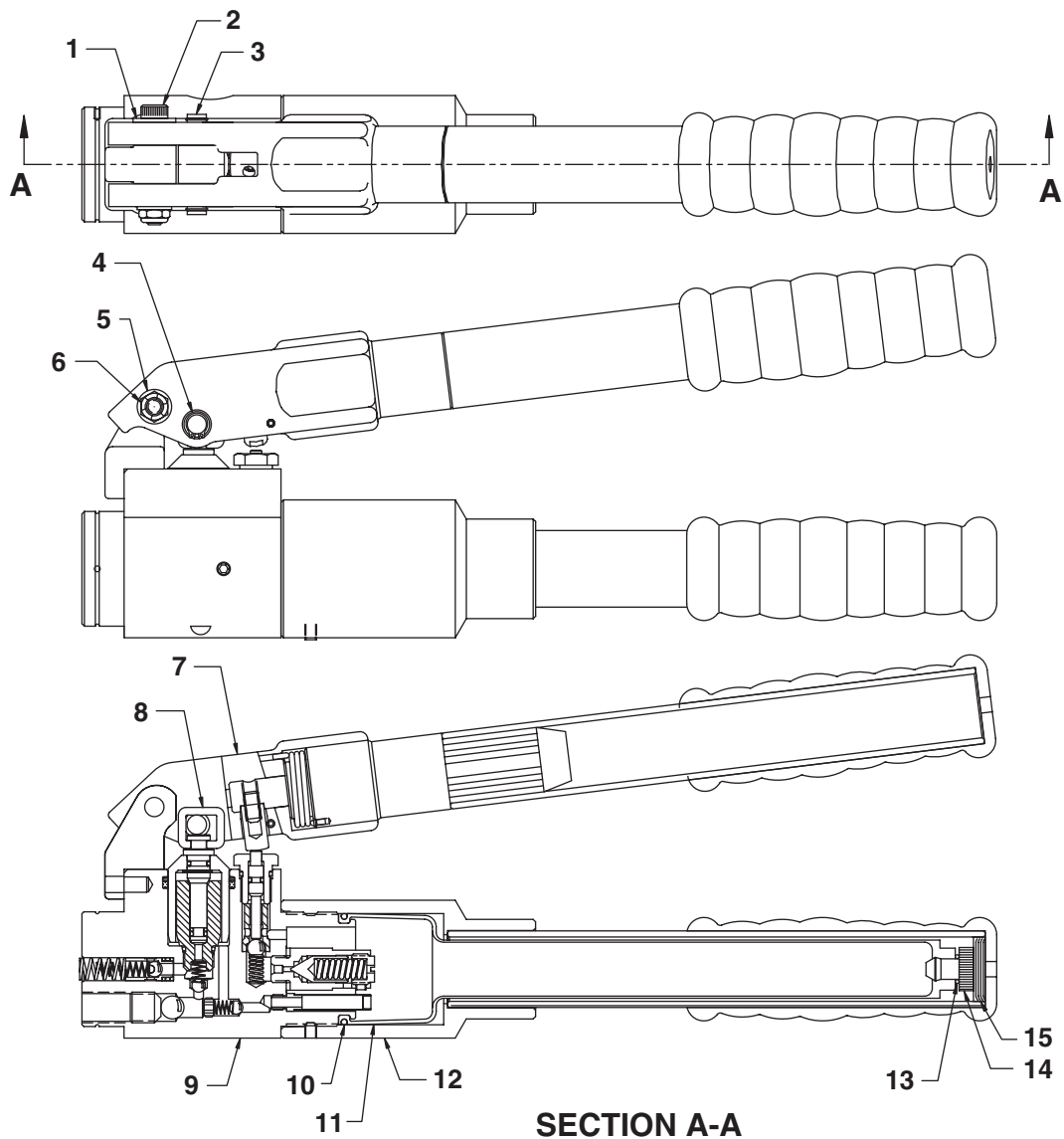

PUMP MECHANISM SUB ASSEMBLY 3000089

Item No.	Part No.	No. Req'd	Description	Item No.	Part No.	No. Req'd	Description
1	5-3913	1	Washer	9	4-0640	1	Block Assembly, Pump
2	252248	1	Screw, Shoulder	10	5-2820	1	O-Ring
3	3-1199	1	Pin, Fulcrum	11	4-0635	1	Bladder
4	251925	2	Ring, Retaining	12	3000087	1	Lever Assembly
5	10228	1	Washer	13	10267	1	O-Ring
6	5-2716	1	Nut, Lock	14	4-0425	1	Plug, Bladder
7	3000088	1	Handle Assembly	15	4-0413	1	Plug, Felt Reservoir
8	3-4917	1	Lifter, Injector				

PARTS LIST

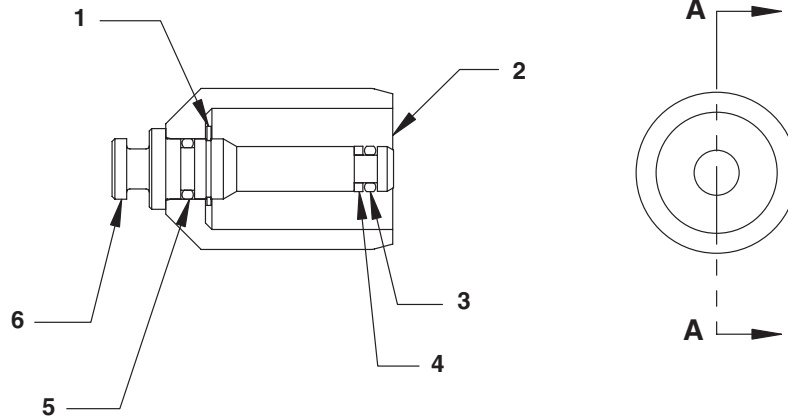

SECTION A-A

INJECTOR SUB - ASSEMBLY 4-0642

Item No.	Part No.	No. Req'd	Description
1	251069	1	Ring, Retaining
2	3-8123	1	Injector, L.P.
3	5-2380	1	O-Ring

Item No.	Part No.	No. Req'd	Description
4	5-2726	1	Ring, Back-Up
5	10266	1	O-Ring
6	4-0643	1	Injector, H.P.

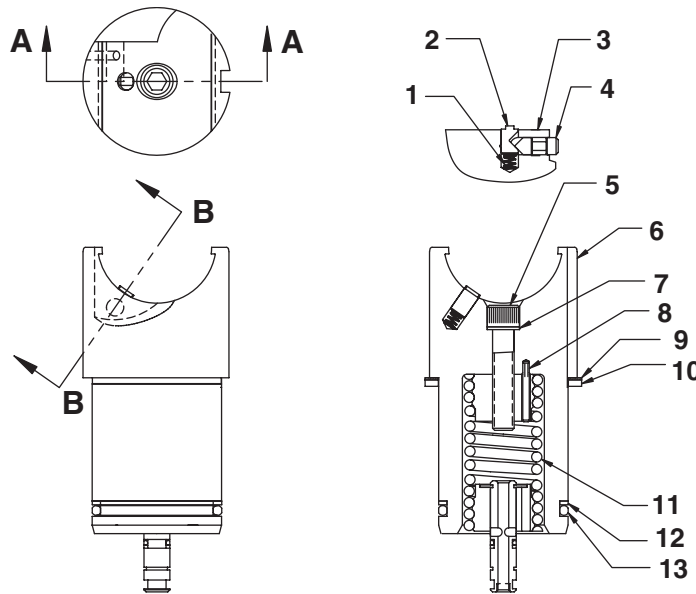

RAM ASSEMBLY 4-0717

Item No.	Part No.	No. Req'd	Description
1	3-1239	1	Spring, Compression
2	3-1241	1	Pin, Retaining
3	5-1269	1	Pin, Spring
4	3-1242	1	Shaft, Release
5	10948	1	Screw, SHC
6	4-0718	1	Body, Ram
7	3-4145	1	Washer, Seal

Item No.	Part No.	No. Req'd	Description
8	5-1996	1	Pin, Drive
9	3-8390	1	Washer
10	3-8391	1	Wiper
11	4-1324	1	Spring Assembly
12	19733	1	Ring, Back-Up
13	5-1263	1	O-Ring