

13-HHC-B HYDRAULIC CUTTER TOOL



INTRODUCTION

The 13-HHC-B Hydraulic Cutter Remote is a lightweight, compact and extremely durable tool that has been designed for cutting a wide variety of materials.

The Cutter features insert type blades that can be easily replaced in the field with the use of only a screw driver. Other features include a hinged "Flip Top" Head and a full 360 Degrees of head rotation.

The Cutter can be operated with any suitable hand or power pump capable of pressure output of 10,000 PSI. No special control valves are required since the cutter piston is spring returned.



WARNING



The 13-HHC is not to be used for hot line work.

SPECIFICATIONS

PUMP SECTION:

Injector Stroke:	.56 in. (1.42 cm)
L P Output Per Stroke:	.441 cu. in. (.007 liter)
H P Output Per Stroke:	.034 cu. in. (.0005 liter)
L P Unloading Valve Setting:	500 psi (3,447 kPA)
L P Relief Valve Setting:	25 psi (172 kPA)
H P Relief Valve Setting:	10,000 psi (68,950 kPA)
Handle Effort:	4.2 lbs. per 1,000 psi (1.90 kg per 6,895 kPA)
Reservoir Capacity:	8.5 cu. in. (.139 liter)
Oil Type Recommended:	Amoco Rykon MV

TOOL SECTION:

Bore Diameter:	1.875 in. (4.76 cm)
Stroke:	2.180 in. (5.54 cm)
Cutting Force:	13.180 tons U.S. (12.5 tons Metric)
Head Rotation:	360 degrees continuous

GENERAL:

Total Weight:	20.1 lbs. (9.1 kg)
---------------	--------------------

Size:	4.15 x 7.39 x 25.66 in. long (10.54 x 18.77 x 65.17 cm long)
-------	--

CUTTING CAPACITY: (See Notes)

Wire Rope:	1 in. (2.54 cm)
Soft Copper/Alum Wire:	1.25 in. (3.17 cm)
Gr. 2 Soft Steel Bolts:	.875 in. (2.22 cm)
Bare Stranded Copper/ Alum Wire:	2.00 in. (5.08 cm)
ACSR Underground Power Cable:	2.00 in. (5.08 cm)
Stranded Galvanized Wire:	.75 in. (1.90 cm)

Notes:

Size shown are for stranded bare wires. When cutting insulated wire, size is over insulation. Rating for soft steel should not exceed ASTM 1022. Rating for hard drawn steel wire should not exceed ASTM 1042.

IMPORTANT SAFETY INFORMATION



This is the safety alert symbol.

It is used to alert you to potential personal injury hazards. Obey all safety messages that follow this symbol to avoid possible injury or death



DANGER

Denotes an imminently hazardous situation which, if not avoided, will result in death or serious injury.



WARNING

Denotes a potentially hazardous situation which, if not avoided, could result in death or serious injury.



CAUTION

Denotes a potentially hazardous situation which, if not avoided, may result in minor or moderate injury.

CAUTION

Caution used without the safety alert symbol indicates a potentially hazardous situation which, if not avoided, may result in property damage.

IMPORTANT

Denotes an operating or service procedure or condition considered essential for expedient and efficient operation and service.



WARNING



It is the operators responsibility to read and understand the following safety statements,

- Only qualified operators should install, operate, adjust, maintain, clean, repair, or transport this machinery.
- Inspect tool before use. Replace any worn or damaged parts. Failure to observe these warning can result in severe injury or death.



WARNING



Keep hands away from the cutter head assembly head when cutting.



To help prevent personal injury,



- Always wear eye protection whenever operating hydraulic equipment.



- Always wear hearing protection as required.

- Operation, repair, or maintenance of hydraulic equipment should be performed by a qualified person who understands the proper function of hydraulic equipment per local directives and standards.
- Hydraulic equipment must be assembled correctly and then checked for proper function before use. Use hydraulic components of the same hydraulic pressure ratings. An appropriate hydraulic pressure gauge is recommended to monitor pressure.



- Never place your hands or other body parts near a hydraulic fluid leak. Never use your hands or other body parts to check for a possible leak.

High pressure fluid can be injected under your skin causing serious injury and/or infection.



WARNING

- Do not exceed cutting capacity of materials listed on sheet one. Cutting of too large or too hard materials could cause blades to shatter and cause injury.



- This tool is not insulated. When using this unit near energized electrical lines, use proper personal protective equipment.



CAUTION

- Do not cut piano or music wire.
- Do not operate cutter with top support open.

IMPORTANT

- Properly dispose of all fluids, components, and assemblies at the end of their useful life.
- Hydraulic fluid should be compatible with all hydraulic components.

OPERATING INSTRUCTIONS

Insert material to be cut between blades.

If part to be cut is very long, open cutter head by pulling out pull pin assembly, slide cutter over part and close head, locking in place with pull pin assembly fully engaged.

Pump lever handle to close bottom blade on material.

After a few strokes, a slight click will be heard indicating that the pump has shifted into the high-pressure stage. Continue pumping lever until material has been cut.

To retract piston, lift lever handle slightly and rotate handle clockwise until it stops. Push handle downward until pressure release plunger has been depressed and piston retracted. Lifting lever slightly at any time will stop piston retraction.

Note:

After extended use or cutting hard materials, blades will become worn and pitted. Kit No. 4-1235 is available from the factory for blade replacement. Replace worn or damaged blades to maintain safe, efficient cutting operations.

Blade Replacement (Kit No. 4-1235)

To replace top blade, withdraw pull pin assembly and open top support. Remove slotted screw and top blade. Insert new top blade with flat side facing bottom blade and secure with new slotted screw and lockwasher.

To replace bottom blade, advance piston until bottom blade screw is exposed. Remove hex socket screw and bottom blade. Insert new bottom blade with flat side facing top blade and secure with new screw.

Close top support and replace pull pin assembly. Cutter is now ready for use.



PERIODIC MAINTENANCE:

Occasionally lubricate pull pins and pivot pins with a molybdenum disulfide grease. The greatest single cause of failure for hydraulic tools is dirt. Extreme caution should be used to prevent the entry of contaminant's into the unit.

Internal Relief Valve

If cutter fails to cut properly when blades appear to be in good condition, the internal relief valve may have lost its proper setting (See "Pressure Gage Port")

Pressure Gage Port

This cutter features a port for the installation of a gage to determine the high-pressure relief valve setting. (See 4-0790 Gage Assembly)

Oil Leaks

A slight weeping of oil from the ram and pump seals is normal and required to keep moving parts lubricated. Excessive leakage indicates a need for seal replacement.

Seal Replacement

Maintenance and repairs of this type should only be preformed by properly trained personnel in repair shops under clean conditions. In addition to all parts shown on keyed parts list, 4-1161 Seal Kit and 4-1065 are available for replacing seals in the cutter head sub-assembly and in the pump mechanism sub-assembly.

Filling Reservoir

To add or replace oil in the cutter, retract blade completely. Loosen the reservoir handle stop screw and remove the handle. Remove the reservoir plug and O-ring seal. Pull the stem of the reservoir bladder out as far as possible. Add oil until it fills the stem. See "Compatible Hydraulic Fluids" section.

TROUBLE SHOOTING

If the blade will not extend completely, and pumping becomes easier, it will generally be found that there is an insufficient amount of oil in the compressor's hydraulic system. This trouble can also be caused by faulty pump plunger packing or release valve packing by the pressure release valve being stuck open, or by foreign matter preventing the release valve balls from seating properly. Faulty packing will usually be detected by excess oil leakage around the pump plunger. A stuck valve ball can usually be freed by rapping the tool sharply.



CAUTION

Avoid damage to other parts in the process of rapping. Foreign matter can frequently be flushed from a valve seat by pumping very rapidly with abrupt strokes.

If the blade will not retract completely, it will generally be found that there is too much oil in the cutter's hydraulic system. Drain enough to permit complete retraction. If the blade will not retract and the oil reservoir is not full, the ram is likely being held by a deformed washer.

A small amount of leakage is desirable around the ram; pump plunger, and pressure release valve plunger to lubricate these parts. If enough leakage occurs to cause the oil to run, the packing should be replaced.

Compatible Hydraulic Fluids:

The use of Amoco Rykon MV oil is recommended. Compatible fluids include:

Mobil DTE 13
Mobil ATF 220
Shell Tellus 32
Arco Dexron III
Citgo AW32
Citgo Dexron III

Other fluids also may be used if they meet or exceed the following specifications:

Viscosity: 180 SSU at 100 degree F.
Flash Point: 350 degree F
Pour Point: -50 degree F

INSTRUCTIONS FOR CONVERSION TO 13-HCR TOOL



13-HHC TOOL

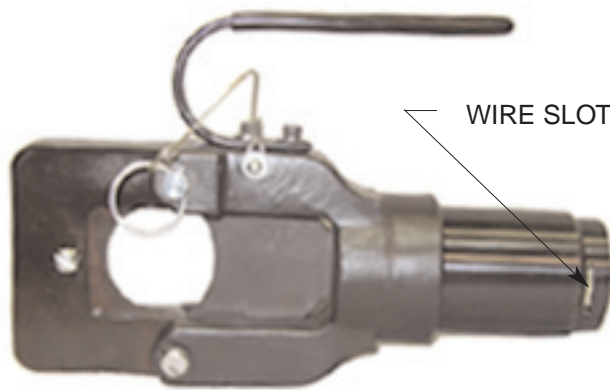

CUTTER HEAD SUB-ASSEMBLY
(PART NUMBER 4-0929)

WIRE SLOT IN CYLINDER



REMOTE END CAP ASSEMBLY
(PART NUMBER 4-0765)



CONVERSION ASSEMBLY
(PART NUMBER 4-0766)

1-RETAINING WIRE
1-WRAP AROUND DECAL

1. Fully retract tool ram and make sure all pressure has dissipated.
2. Place tool in a vise with handles pointing upward. Remove adhesive label covering slot in cylinder.
3. Pry hooked end of retaining wire out of slot in cylinder.
4. Holding hooked end of wire with pliers, rotate cylinder to force retaining wire out of groove and through slot. Discard wire.
5. Carefully separate pump assembly from cylinder assembly, holding discharge spring in place.
6. Apply lubricant to groove in end cap of remote tool and to retaining wire.
7. Insert end cap into back end of cylinder assembly. Rotate cylinder assembly until hole in end cap appears in slot in cylinder.
8. Place hooked end of new wire from conversion kit into hole in end cap. Align free length of wire along slot in cylinder. Rotate cylinder assembly in opposite direction to feed wire through slot and into groove.
9. When wire is fully engaged, hooked end will snap out of hole in end cap to permit full head rotation. Wedge spring pin in slot in cylinder, allowing wire to move freely beneath. Seal slot with new adhesive label.
10. Purge air from remote tool and pump system using normal fill and bleed procedures.

PARTS LIST

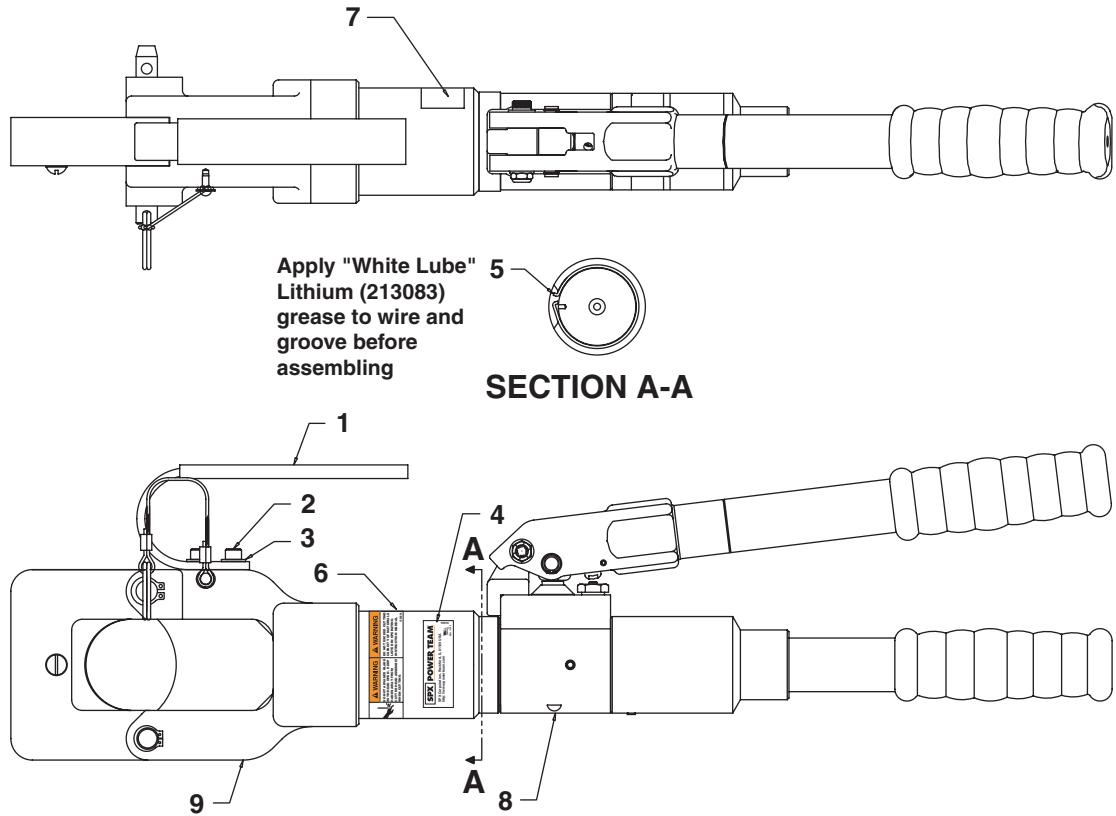

13-HHC-B

Item No.	Part No.	No. Req'd	Description
1	4-0812	1	Handle Assembly, Lift
2	10006	2	Screw, Socket Head
3	10228	2	Washer, Plain
4	1000056	1	Decal, (Tradename Power Team)
5	3-9678	1	Retaining Wire
6	1000054	1	Decal, (Warning)
7	420691	1	Decal, (Product Blank)

Item No.	Part No.	No. Req'd	Description
8	3000089	1	Pump, Mechanical Sub Assembly
9	4-0929	1	Cutter Head Sub Assembly
	ITEM NOT SHOWN		
	2000147	1	Bag, Nylon Carrying

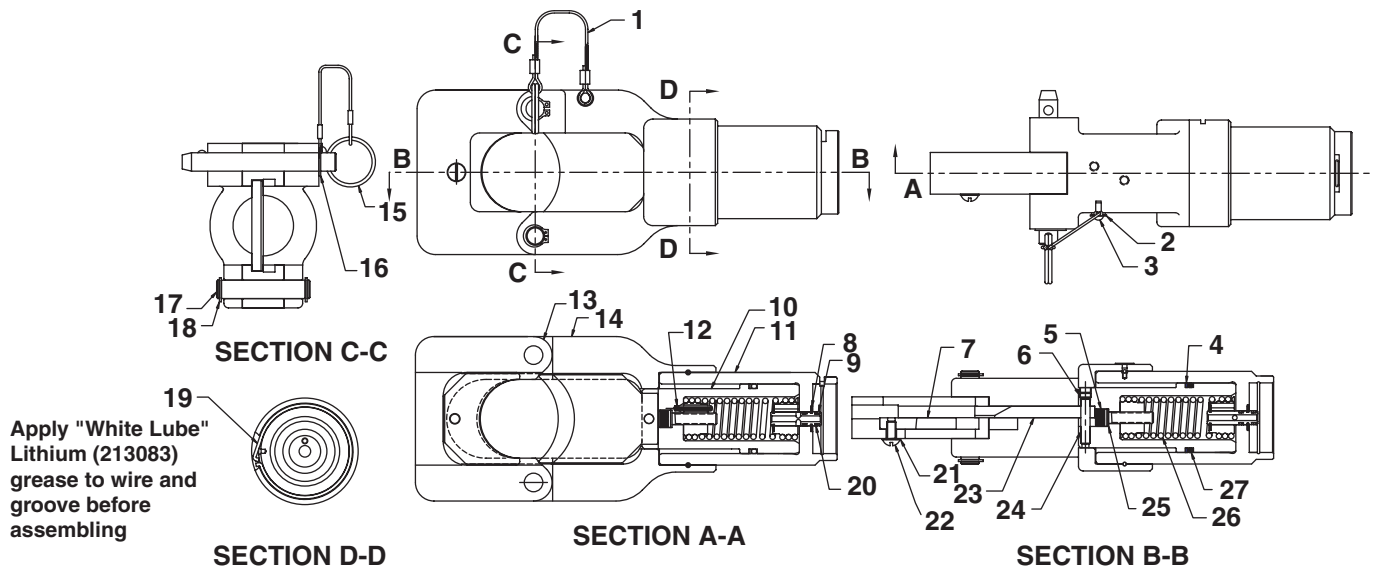

CUTTER-HEAD SUB ASSEMBLY 4-0929

Item No.	Part No.	No. Req'd	Description	Item No.	Part No.	No. Req'd	Description
1	3-9008	1	Cable Assembly	15	5-3859	1	Pin Assembly, Pull
2	11089	1	Washer, Flat	16	5-3860	1	Ring, Grip
3	5-3481	1	Screw, Drive	17	3-8223	1	Pin, Pivot
4	19733	1	Washer, Back-up	18	5-3172	2	Retaining Ring
5	10809	1	Screw, Soc. Hd. (5/16-18 x 1-1/4)	19	3-9007	1	Retaining Wire
6	5-0873	1	Screw, Hollow Set	20	5-3245	1	Ring, Back-Up
7	3-9698	1	Blade, Top	21	11351	1	Washer, Ext. Tooth
8	11032	1	Ring, Retaining	22	10174	1	Screw, Rd. Hd. (1/4-20 x 1/2)
9	10266	1	O-Ring	23	3-9699	1	Blade, Bottom
10	3-9005	1	Piston	24	5-3914	1	Pin
11	4-0669	1	Cylinder	25	3-4145	1	Washer, Nylon
12	5-2386	1	Pin, Spring	26	4-0670	1	Spring Assembly
13	3-9700	1	Support, Top	27	5-3427	1	O-Ring
14	4-0668	1	Yoke				

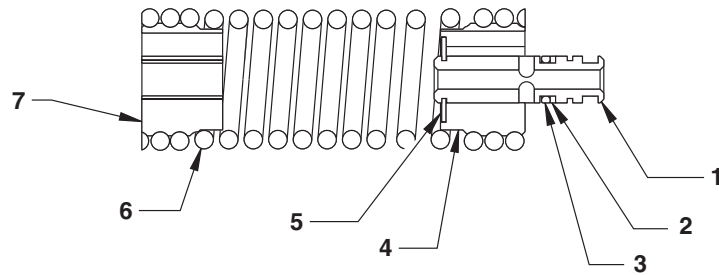

SPRING ASSEMBLY - 4-0670

Item No.	Part No.	No. Req'd	Description	Item No.	Part No.	No. Req'd	Description
1	3-9680	1	Tube, Transfer	5	11032	1	Ring, Retaining
2	5-3245	1	Ring, Back-Up	6	3-4144	1	Spring, Tension
3	10266	1	O-Ring	7	3-9012	1	Retainer, Threaded
4	3-9683	1	Retaining, Swivel				

PARTS LIST

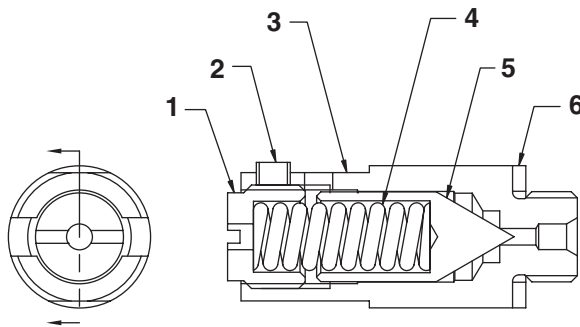

HIGH PRESSURE RELIEF VALVE 3-2716

Item No.	Part No.	No. Req'd	Description	Item No.	Part No.	No. Req'd	Description
1	3-1091	1	Screw, Adjusting	4	3-1234	1	Spring, Compression
2	5-1264	1	Screw, Set	5	3-0654	1	Plunger, Valve
3	3-1232	1	Body, Valve	6	3-1233	1	Washer, Seal

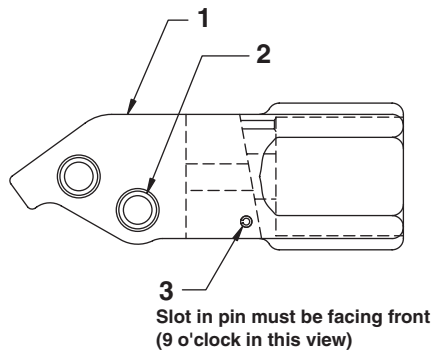
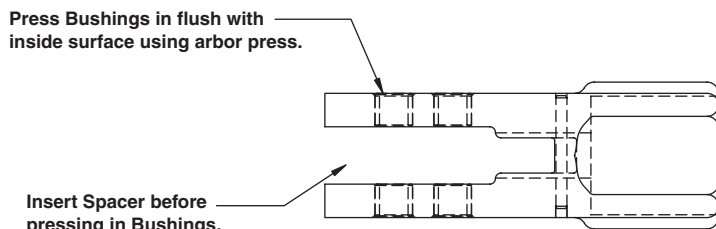

LEVER HEAD SUB-ASSEMBLY 3-8352

Item No.	Part No.	No. Req'd	Description	Item No.	Part No.	No. Req'd	Description
1	3-8348	1	Head, Lever	3	11566	1	Pin, Spring
2	3-4838	4	Bushing				

PARTS LIST

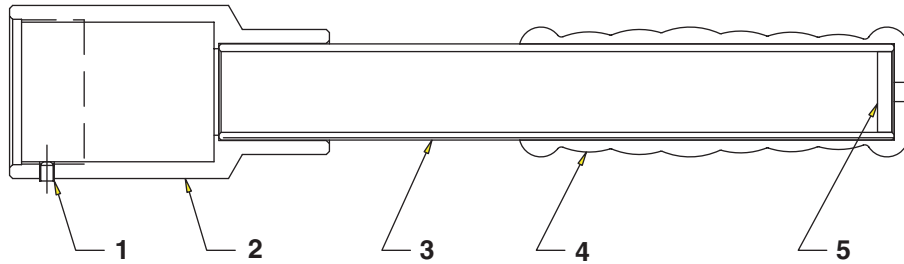
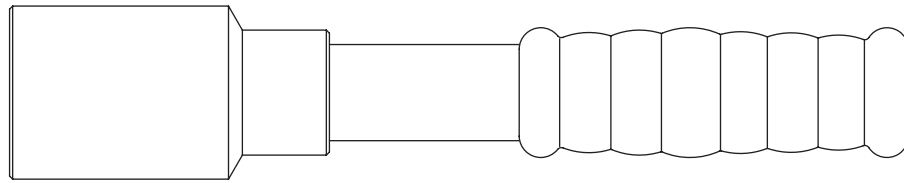

SECTION VIEW

RESERVOIR HANDLE ASSEMBLY 3000087

Item No.	Part No.	No. Req'd	Description	Item No.	Part No.	No. Req'd	Description
1	5-0425	1	Screw, Set	4	3-5056	1	Grip, Handle
2	3000086	1	Handle/Adapter Sub-Assembly	5	4-0413	1	Plug, Felt
3	5-2377	.1 oz	Cement				

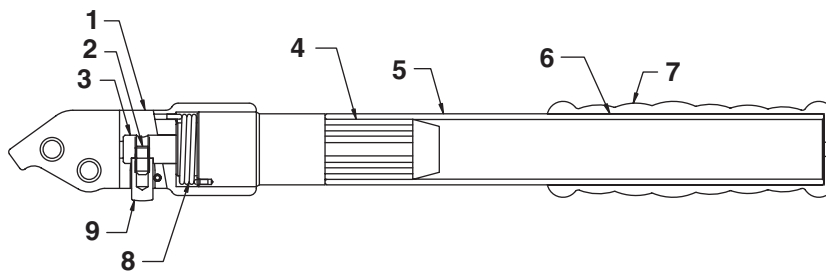
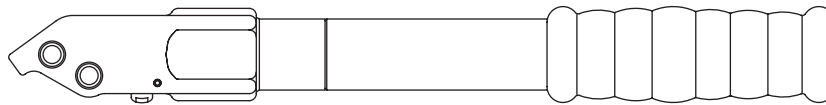

LEVER ASSEMBLY 3000088

Item No.	Part No.	No. Req'd	Description	Item No.	Part No.	No. Req'd	Description
1	3-8352	1	Head Sub-Assembly, Lever	6	5-2377	.1 oz.	Cement
2	10138	1	Screw, Set	7	3-5056	1	Grip, Handle
3	3-8349	1	Shaft, Release	8	3-8351	1	Spring, Torsion
4	5-2538	.1 oz.	Adhesive	9	3-8350	1	Pin, Striker
5	2000148	1	Handle				

PARTS LIST

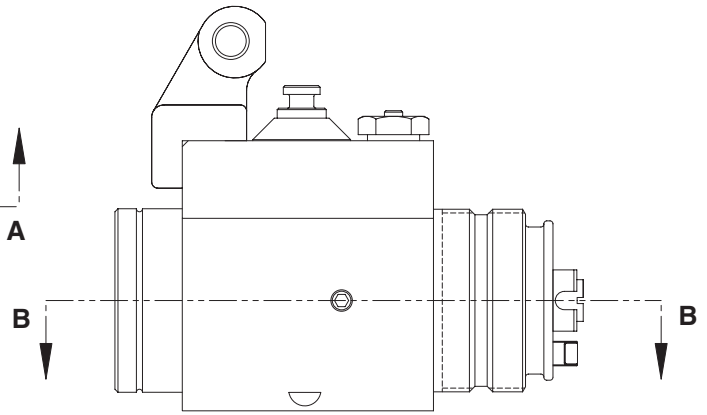
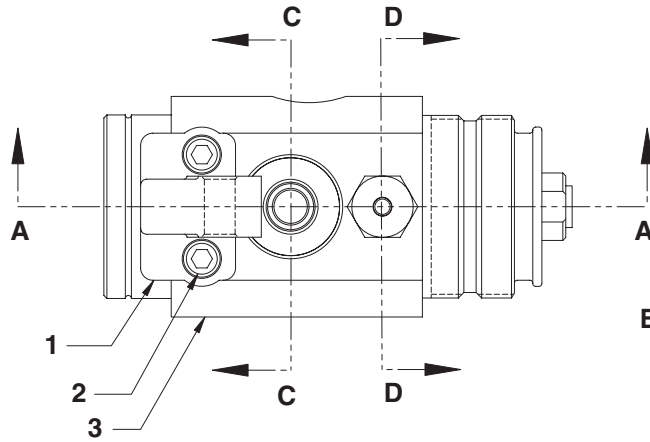

PUMP BLOCK ASSEMBLY 4-0640

Item No.	Part No.	No. Req'd	Description
1	3-5134	1	Bracket, Fulcrum
2	10008	2	Screw, SHC

Item No.	Part No.	No. Req'd	Description
3	3-9676	1	Block, Pump

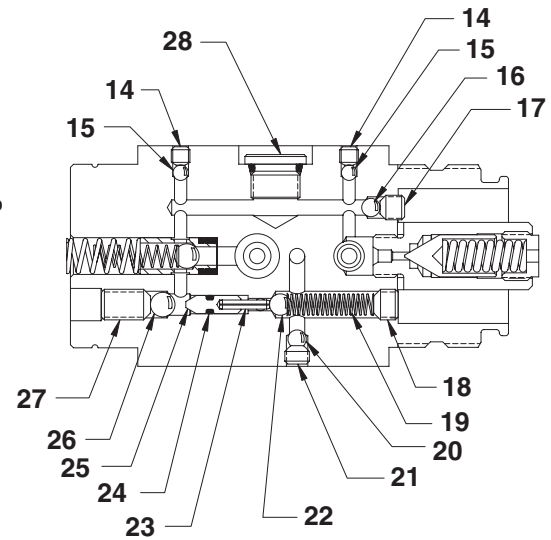
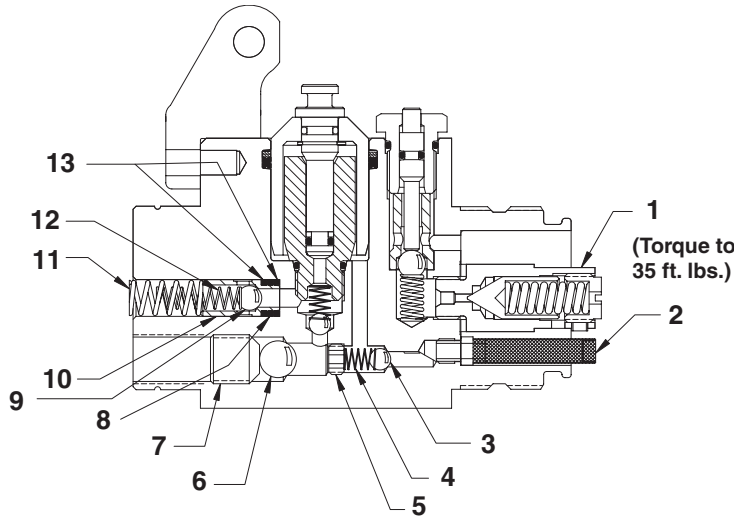

SECTION A-A

PUMP BLOCK ASSEMBLY 4-0640

SECTION B-B

Item No.	Part No.	No. Req'd	Description
1	3-2716	1	Valve, H.P. Relief
2	3-7629	1	Filter, Intake
3	10374	1	Ball
4	3-5129	1	Spring, Compression
5	5-0873	1	Screw, Hollow
6	10378	1	Ball
7	5-2551	1	Screw, Set
8	10266	1	O-Ring
9	10375	1	Ball
10	4-0495	1	Insert, H.P. Discharge
11	5-2923	1	Spring, Compression
12	5-3674	1	Spring, Compression
13	12184	1	Ring, Back-Up
14	5-0341	2	Screw, Set
15	10419	2	Ball

Item No.	Part No.	No. Req'd	Description
16	12223	1	Ball
17	5-0343	1	Screw, Set
18	5-0659	1	Screw, Set
19	5-1992	1	Spring, Compression
20	12223	1	Ball
21	5-3399	1	Screw, Set
22	10374	1	Ball
23	5-0121	1	Pin, Spring
24	5-3261	1	O-Ring
25	3-7474	1	Plunger, L.P.
26	10375	1	Ball
27	5-0649	1	Screw, Set
28	5-3855	1	Plug, Seal

PARTS LIST

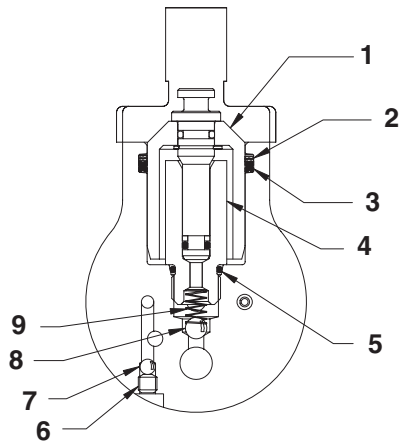

SECTION C-C

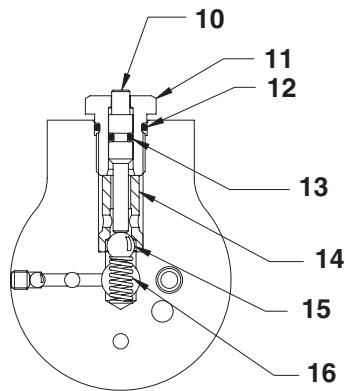

SECTION D-D

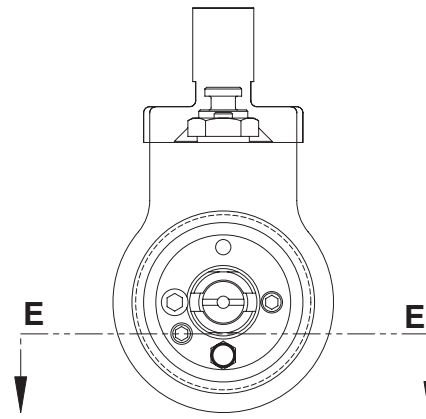

SECTION E-E

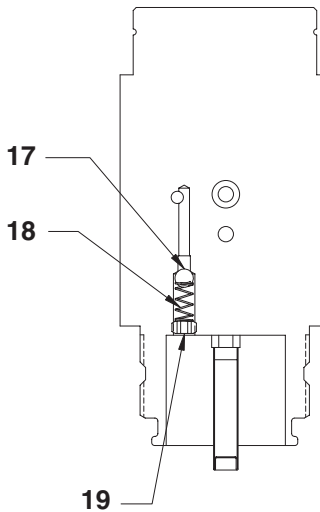

PUMP BLOCK ASSEMBLY 4-0640

Item No.	Part No.	No. Req'd	Description
1	4-0642	1	Injector Assembly
2	5-0049	1	Ring, Back-Up
3	5-3341	1	Quad-Ring
4	4-0641	1	Housing, H.P.
5	12098	2	O-Ring
6	5-0341	1	Screw, Set
7	10419	1	Ball
8	10374	1	Ball
9	3-5129	1	Spring, Compression
10	3-5011	1	Plunger, Release

Item No.	Part No.	No. Req'd	Description
11	3-5010	1	Screw
12	12098	2	O-Ring
13	10264	1	O-Ring
14	3-5009	1	Insert
15	10423	1	Ball
16	5-3000	1	Spring, Compression
17	12223	1	Ball
18	5-3260	1	Spring, Compression
19	5-2062	1	Screw, Set

PARTS LIST

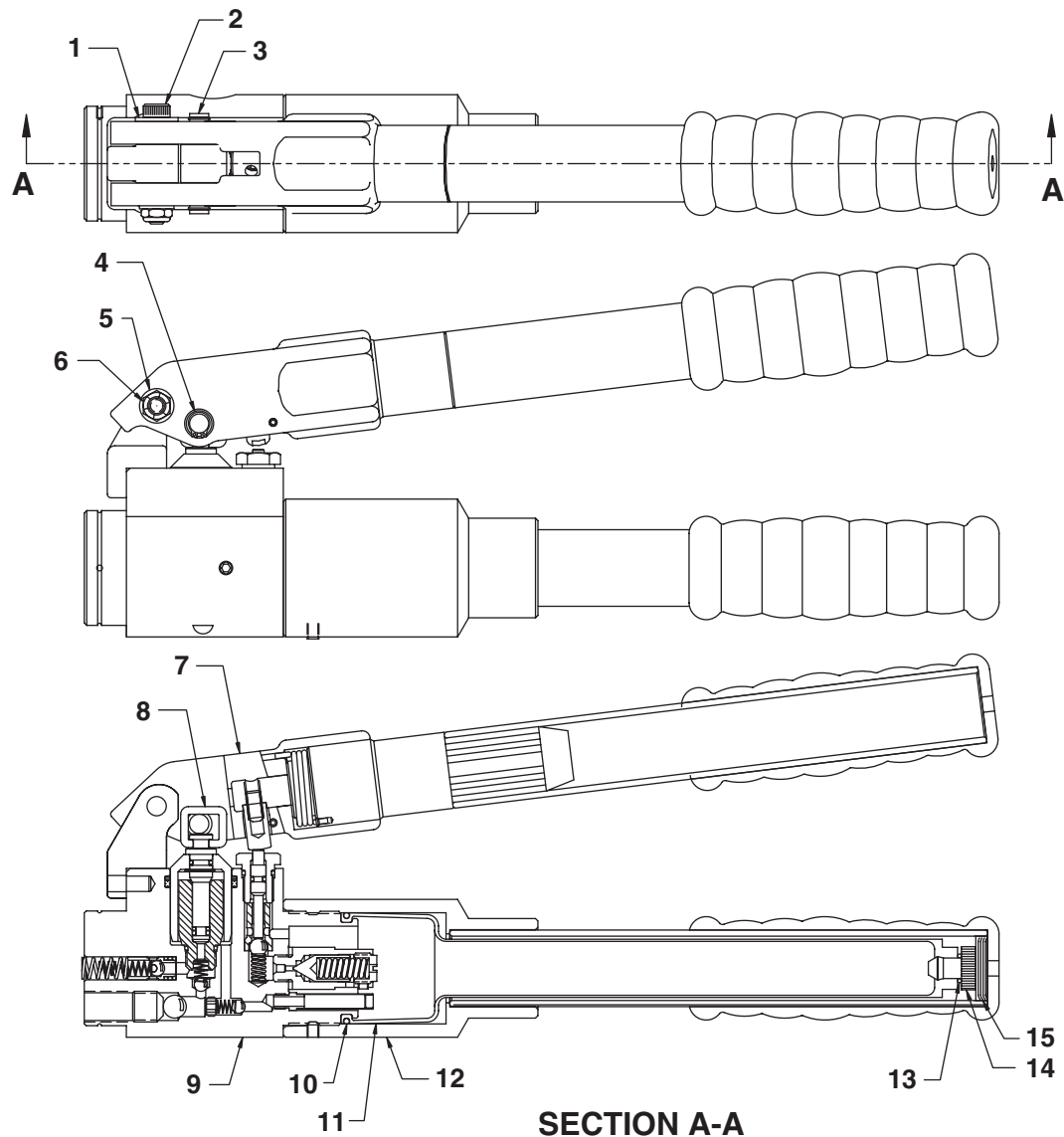

PUMP MECHANISM SUB ASSEMBLY 3000089

Item No.	Part No.	No. Req'd	Description	Item No.	Part No.	No. Req'd	Description
1	5-3913	1	Washer	9	4-0640	1	Block Assembly, Pump
2	252248	1	Screw, Shoulder	10	5-2820	1	O-Ring
3	3-1199	1	Pin, Fulcrum	11	4-0635	1	Bladder
4	251925	2	Ring, Retaining	12	3000087	1	Lever Assembly
5	10228	1	Washer	13	10267	1	O-Ring
6	5-2716	1	Nut, Lock	14	4-0425	1	Plug, Bladder
7	3000088	1	Handle Assembly	15	4-0413	1	Plug, Felt Reservoir
8	3-4917	1	Lifter, Injector				

PARTS LIST

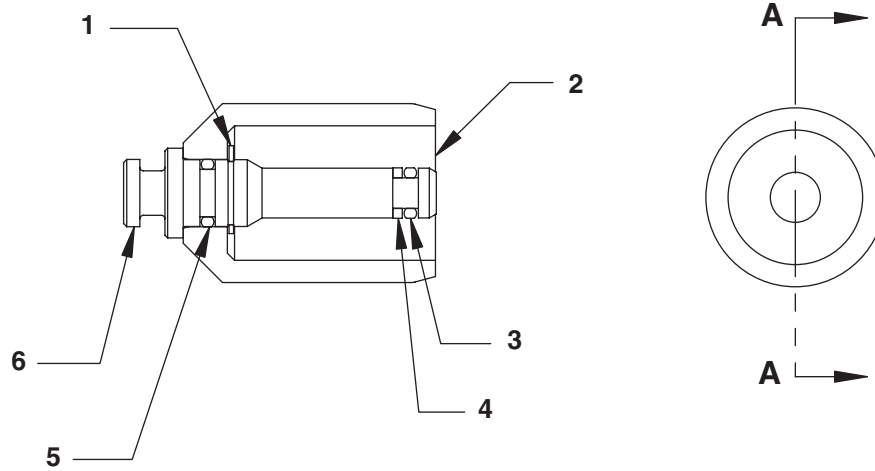

SECTION A-A

INJECTOR SUB - ASSEMBLY 4-0642

Item No.	Part No.	No. Req'd	Description	Item No.	Part No.	No. Req'd	Description
1	251069	1	Ring, Retaining	4	5-2726	1	Ring, Back-Up
2	3-8123	1	Injector, L.P.	5	10266	1	O-Ring
3	5-2380	1	O-Ring	6	4-0643	1	Injector, H.P.