

## Technical data | TQS - series

- 4-gear **full metal** gear
- **Brushless** PowerDrive motor with 30% higher efficiency
- Li-ion rechargeable battery with **SafetyCell** Technology.
- Motor and electronics are completely **dust-protected**
- **High rotational speed** for precise and fast bolting
- Aluminium support for **weight reduction** and higher operating comfort
- Newly developed narrow gear body

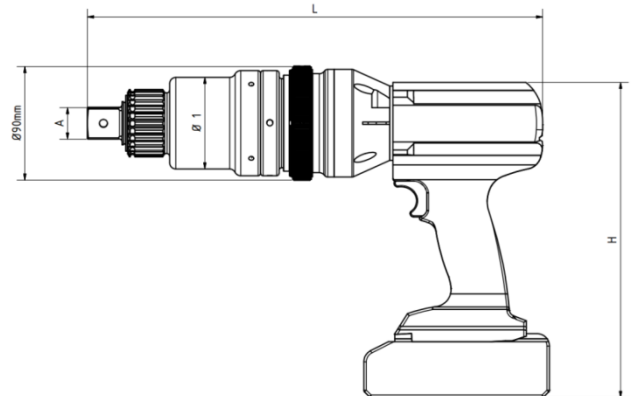

Typ		TQS-065	TQS-095	TQS-130	TQS-220	TQS-300	TQS - 400
Art.- Nummer		59 065 110	59 095 120	59 130 130	59 220 140	59 300 150	59 400 160
Leistungsbereich		50 - 650 Nm	100 - 950 Nm	100 - 1.300 Nm	100 - 2.200 Nm	100 - 3.000 Nm	150 - 4.000Nm
Drehzahl	1 Gang	8 U/min	7,7 U/min	4,25 U/min	2,1 U/min	1,2 U/min	1,25 U/min
Drehzahl	2 Gang	16 U/min	15 U/min	8,5U/min	4,2 U/min	2,5 U/min	2,5 U/min
Drehzahl	3 Gang	36 U/min	35 U/min	20 U/min	9,5 U/min	6 U/min	5,5 U/min
Drehzahl	4 Gang	70 U/min	66 U/min	39 U/min	18 U/min	12 U/min	11 U/min
Länge mm		380	390	380	410	410	410
Höhe mm		250	250	250	250	250	250
Breite(Antriebsmaschine)mm		80	80	80	80	80	80
Durchmesser Verriegelung mm		90	90	90	90	90	90
Durchmesser Getriebe mm		75	75	88	88	88	88
Werkzeugantrieb Zoll		3/4"	3/4" - 1"	1"	1"	1"	1 1/2"
Gewicht ohne Abstützung		4,75 kg	6,8kg	6,9 kg	8,2 kg	8,3 kg	9,5 kg