

TFA15TI

INTEGRAL
HYDRAULIC
FLANGE
ALIGNMENT
TOOL



CONTENTS

1. INTRODUCTION
2. TOOL SAFETY
 - 2.1 GENERAL SAFETY
 - 2.2 PERSONNEL COMPETENCY
 - 2.3 DISCLAIMER
 - 2.4 DEFINITION OF TERMS
 - 2.5 HAZARDS
3. TOOL OPERATION
 - 3.1 GENERAL GUIDANCE
 - 3.2 HANDLING
 - 3.3 TOOL INSTALLATION
 - 3.4 ADJUSTMENT LEG
 - 3.5 WING EXTENSION
 - 3.6 CYLINDER ADJUSTMENT SLEEVE
 - 3.7 TOOL CHECKS
 - 3.8 ALIGNMENT
 - 3.9 SECURING THE FLANGE JOINT
4. TOOL MAINTENANCE
 - 4.1 INSPECTION
 - 4.2 CLEANING
 - 4.3 SERVICING
 - 4.4 LUBRICATION PROCEDURE
 - 4.5 STORAGE & TRANSPORTATION
 - 4.6 OPERATING CONDITIONS
 - 4.7 SUB-SEA USAGE
5. TFA15TI
 - 5.1 TOOL CAPABILITIES
 - 5.2 TOOL FUNCTION
 - 5.3 KIT CONTENTS
 - 5.4 DIMENSIONS
6. TROUBLESHOOTING
 - 6.1 TFA15TI TROUBLESHOOTING
7. REGULATORY INFORMATION
 - 7.1 REGISTERED HEAD OFFICE
 - 7.2 APPLICABLE PATENT NUMBERS
8. PARTS LISTS & SERVICE KITS

03/07/14

1.

INTRODUCTION

The Equalizer™ TFA hydraulic flange alignment tool has been developed to assist in the aligning of large flanges on the inside of large pipes, for example those which make up the tower sections of a wind-turbine.

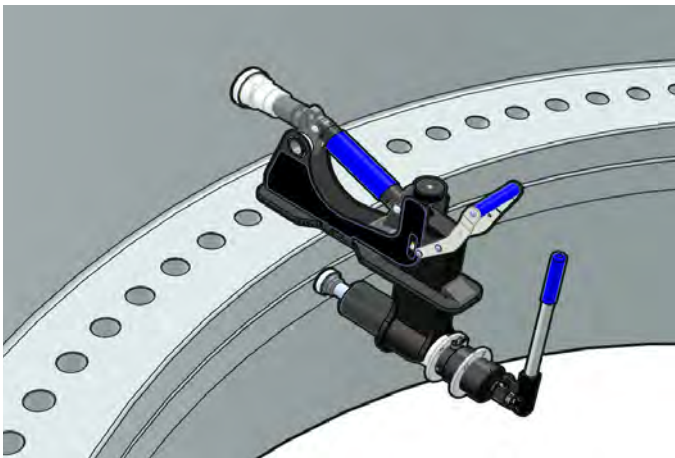

The tool has been designed to cope with the larger loads and dimensions associated with these flange joints while remaining relatively lightweight and user-friendly.

It is essential that the user familiarises themselves with the contents of this manual prior to using the tool.

This manual contains information for the following tools:

- TFA15TI Integral Hydraulic Flange Alignment Tool

2.

TOOL SAFETY

2.1

GENERAL SAFETY

These instructions cover the safe operation and maintenance of THE EQUALIZER **TFA15TI** FLANGE ALIGNMENT tool. The use of any tools should be as part of a broader task-based risk assessment, which should be carried out by the operation supervisor or other competent person.

Failure to comply with the safety information contained within this manual could result in personal injury or equipment damage. Read all instructions, warnings and cautions carefully, and follow all safety precautions.

The safety of the operator, any assisting personnel and the general public is of paramount importance. Always work in accordance with applicable national, local, site & company-wide safety procedures.

2.2

PERSONNEL COMPETENCY

Only personnel deemed competent in the use of mechanical and hydraulic equipment should use these tools.

2.3

DISCLAIMER

Equalizer cannot be held responsible for injury or damage resulting from unsafe product use, lack of maintenance or incorrect product and/or system operation. If in doubt as to the safety precautions and applications, contact Equalizer using the contact details at the back of this manual.

2.4

DEFINITION OF TERMS

A CAUTION is used to indicate correct operating or maintenance procedures and practices to prevent damage to, or destruction of equipment or other property.

A WARNING indicates a potential danger that requires correct procedures or practices to avoid personal injury.

A DANGER is only used when your action or lack of action may cause serious injury or even death.



DO: an illustration showing how the tool should be used.



DON'T: an illustration showing an incorrect way to use a tool.

2.5

HAZARDS



WARNING: ensure all hydraulic components are rated to a safe working pressure of 700bar (10,000psi).



WARNING: Do not overload equipment. The risk of hydraulic overloading can be minimised by using the Equalizer Hand Pump, which has a factory-set safety valve preventing the safe working pressure being exceeded.

If alternative hydraulic pumps are used, ensure that there are adequate systems to limit the the working pressure to 700 bar (10,000 psi).



CAUTION: ensure components are protected from external sources of damage, such as excessive heat, flame, moving machine parts, sharp edges and corrosive chemicals.



CAUTION: Take care to avoid sharp bends and kinks in hydraulic hoses. Bends and kinks can cause severe back-up pressure and cause hose failure. Protect hoses from dropped objects; a sharp impact may cause internal damage to hose wire strands. Protect hoses from crush

risks, such as heavy objects or vehicles; crush damage can cause hose failure.



WARNING: Applying pressure to a damaged hose may cause it to rupture.



WARNING: Immediately replace worn or damaged parts. Use only genuine Equalizer parts from approved distributors or service centres. Equalizer parts have been engineered and manufactured to be fit-for-purpose.



DANGER: To minimise risk of personal injury keep hands and feet away from the tool and workpiece during operation.



WARNING: Always wear suitable clothing and Personal Protective Equipment (PPE). Do not handle pressurised hoses; escaping oil under pressure can penetrate the skin, causing serious injury. Seek medical attention immediately if oil penetration is suspected.



WARNING: Only pressurize complete and fully connected hydraulic systems. Do not pressurize systems that contain unconnected couplers.



CAUTION: Do not lift hydraulic equipment by the hoses or couplers. Use only the designated carrying handles.



CAUTION: Lubricate tools as directed in this manual prior to operation. Use only approved lubricants of high quality, following the lubricant manufacturers instructions.

3.

TOOL OPERATION

3.1

GENERAL GUIDANCE

Prior to alignment, an assesment should be carried out to determine the most appropriate positioning of the tool on the flange joint.



The TFA flange alignment tool should always be installed in such a way that the lower flange is closer to the user and the upper flange is further away. The tool is designed to hook into the bolt-hole of the upper flange and push the lower flange into alignment.



Prior to installation, ensure the Adjustment Leg and Cylinder Adjustment Sleeve are fully retracted. Ensure that the Alignment piston is fully retracted.

3.2

HANDLING

The tool should be lifted and manouvered using its two handles.

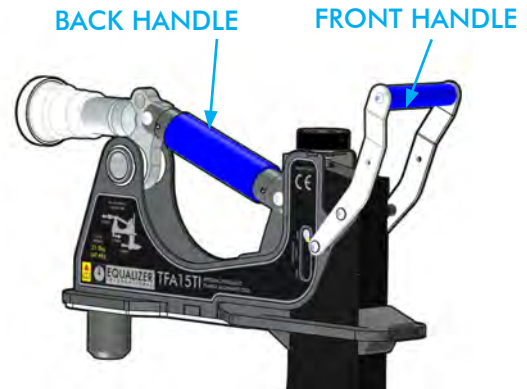

3.3

TOOL INSTALLATION

Position the tool into the bolt-hole ensuring that the hook is fully located into the bolt-hole and the base plate of the tool is sitting flat against the upper flange.

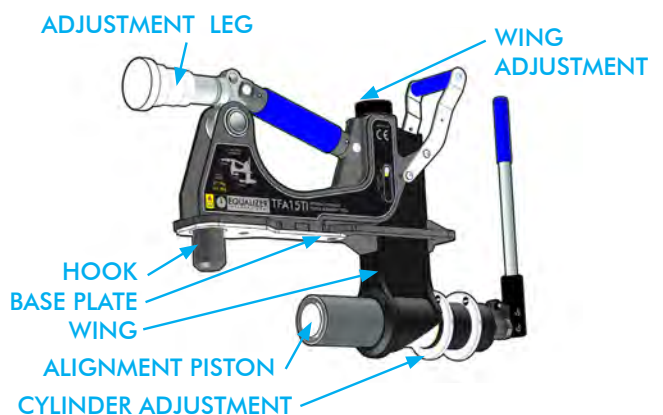
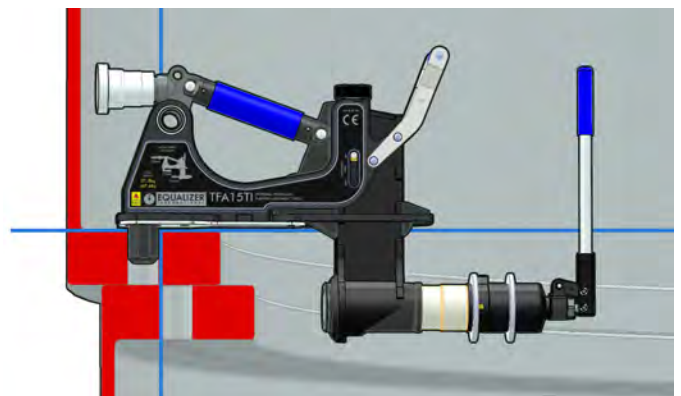

3.4 ADJUSTMENT LEG

Extend the Adjustment Leg by turning the knurled foot clockwise until it contacts the pipe wall. Ensure that the tool is sitting squarely.

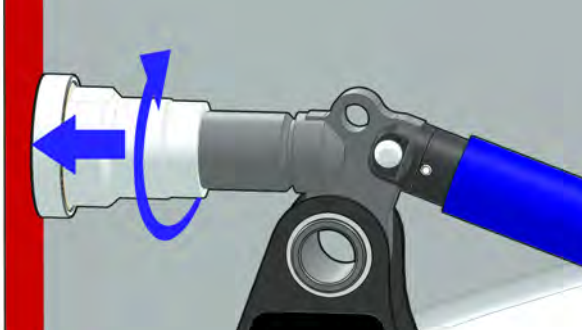

3.5 WING EXTENSION

The Alignment Piston is located on an adjustable wing which can be extended to enable the tool to be used on a variety of flange sizes.

Use the Wing Extension adjustment knob to lower the wing until the foot of the Alignment piston is positioned within the space between the upper and lower faces of the lower flange.

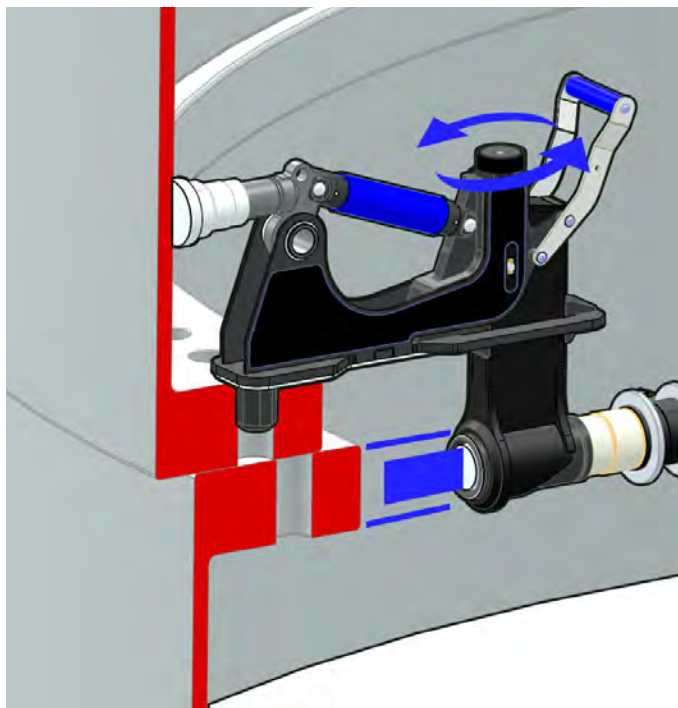

3.6 CYLINDER ADJUSTMENT SLEEVE

The Alignment Piston has a 65mm stroke. The Cylinder Adjustment Sleeve extends the reach of the tool to fit a variety of flange sizes, without compromising its maximum alignment capacity.

Turn the Cylinder Adjustment Sleeve by the knurled ring until the Alignment Foot is touching the lower flange.

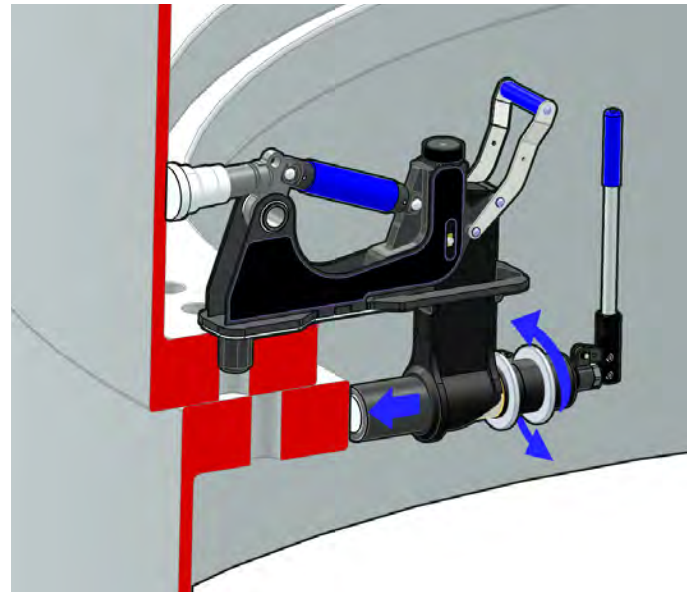

3.7

TOOL CHECKS



Ensure that the tool is sitting square on the flange, that the wing is parallel to the pipe wall and that the Adjustment Leg is adjusted prior to actuating the tool. Actuating the tool when it is not correctly installed could cause injury or equipment damage.

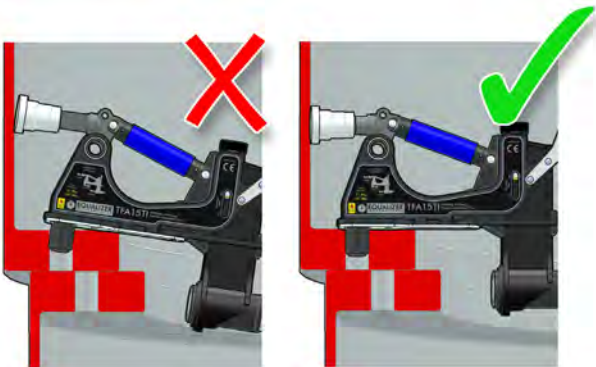
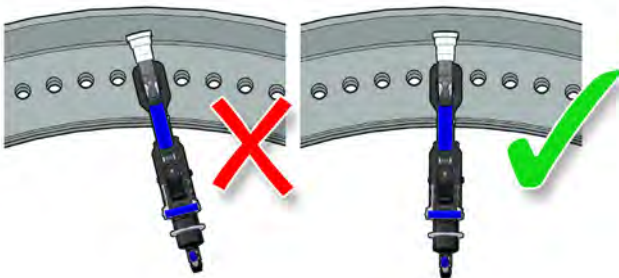
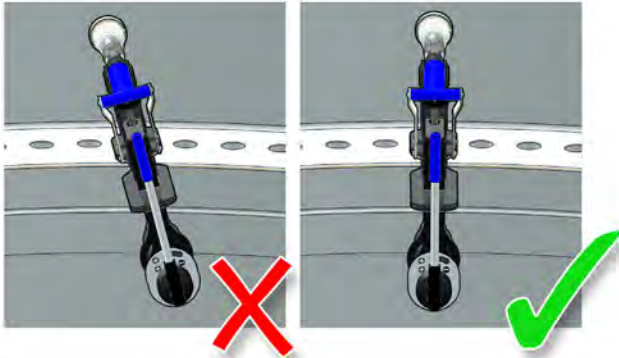

Do not allow fingers, hands or other body parts to come into contact with the flange while actuating the tool. Only hold the tool by its designated handles.

3.8

ALIGNMENT

Refer to section 5.2 for tool actuation instructions.

Actuating the tool will extend the Alignment Piston and align the flanges.

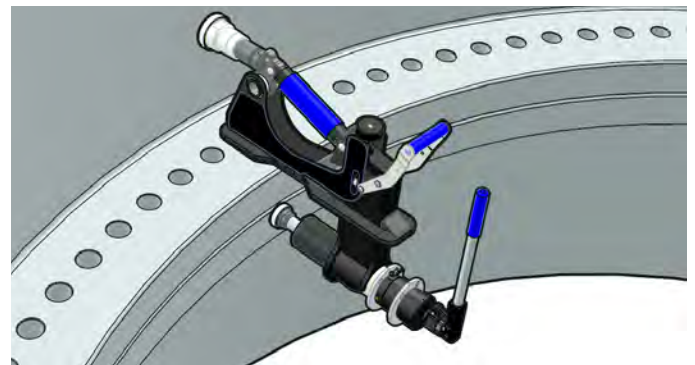
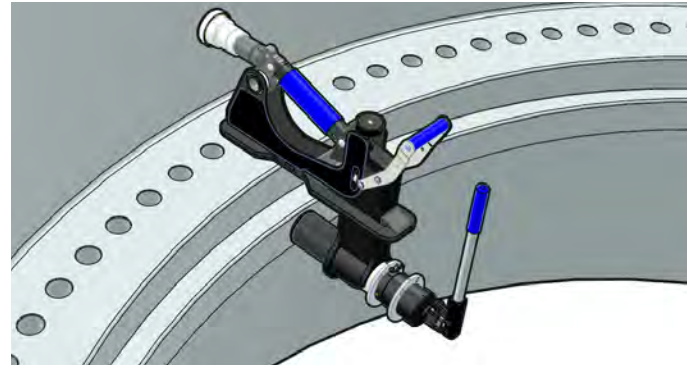

3.9

SECURING THE FLANGE JOINT

After the flange joint has been aligned it can be secured by installing as many bolts as possible into the bolt holes.

It may be necessary to repeat the alignment process several times while working around the flange joint.

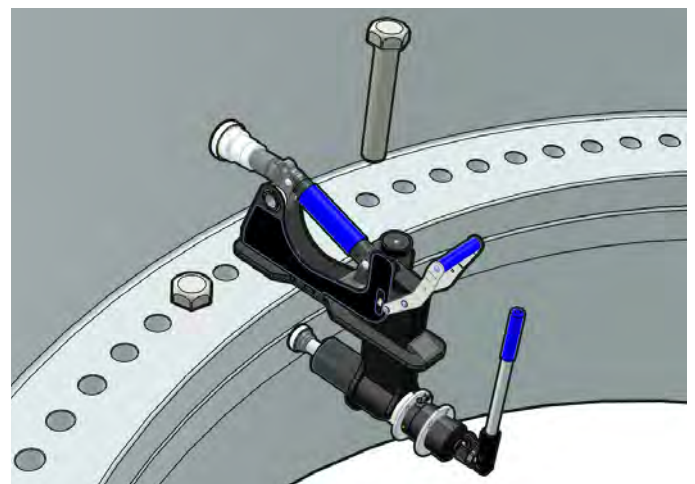

4.

TOOL MAINTENANCE

4.1 INSPECTION

A thorough inspection should be carried out prior to usage, storage or transportation to ensure the completeness and condition of the tool.

Inspection should include:

- visual inspection of the outer parts of the tool, checking for obvious damage, degradation or missing parts
- visual inspection of the Alignment Piston (requiring tool actuation). Damage to the Alignment Piston can be indicative of tool over-load.

Cleaning and servicing should be undertaken as required prior to the tool being used, stored or transported.

4.2 CLEANING

To lightly clean the tool, wipe gently with a damp cloth.

If more thorough cleaning is required (for example following immersion in water) carry out the following cleaning procedure:

- strip the tool down, observing the schematics in section 8.
- clean the components using detergent, following the manufacturer's guidelines
- rinse the components to remove traces of detergent
- dry the components thoroughly

Inspect, service and lubricate the tool immediately after the cleaning process.

4.3 SERVICING

Replace missing worn or damaged parts. Use only genuine Equalizer parts from approved distributors or service centres. Equalizer parts have been engineered and manufactured to be fit-for-purpose.

Grease all moving parts by following the Lubrication Procedure prior to usage, storage or transportation.

If topping up or replacing hydraulic oil as part of a service, use only premium quality hydraulic oil of the grade 15cSt.

4.4 LUBRICATION PROCEDURE

Apply grease following cleaning and servicing, prior to usage, storage or transportation. Never assemble and leave a tool without following the greasing procedure as degradation or damage may occur.

Use only high pressure molybdenum disulphide grease.

Apply grease liberally to the following areas:

- the Adjustment Leg thread
- the Wing Extension thread
- the Cylinder Adjustment thread

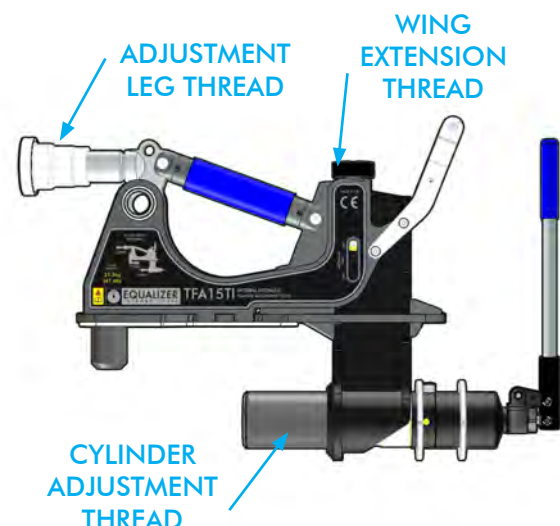

4.5

STORAGE & TRANSPORTATION

Equalizer tools should be stored in a cool dry place. Tools should always be cleaned, serviced and lubricated prior to storage. Ensure that tools are stored in their designated packing cases.

4.6

OPERATING CONDITIONS

HYDRAULIC TOOLS:

Minimum Flange Contact Temperature: -30°C (-22°F)

Maximum Flange Contact Temperature: 70°C (158°F)

4.7

SUB-SEA USAGE

Using TFA15TI Sub-Sea

The TFA15TI is actuated by means of single-acting spring-return hydraulic cylinder and can be used sub-sea providing the following actions are taken:

- The pump release valve is fully opened and remains open until the tool has descended to the working depth. This will allow the pressure to equalise.
- The tool is actuated via the hand pump by a diver.
- Upon completion of works the release valve is left in the fully-open position until the tool has ascended to the surface.
- The tool and pump are stripped-down, cleaned and lubricated immediately to minimise corrosion.

5.

TFA15TI

INTEGRAL HYDRAULIC FLANGE ALIGNMENT TOOL

The TFA15TI flange alignment tool uses an integral hydraulic cylinder to advance the alignment foot and align the flanges.

5.1

TFA15TI TOOL CAPABILITIES

ALIGNMENT FORCE

With the maximum integral pump pressure applied, the tool can apply 15T of alignment force through the alignment foot. Depending on the extension of the wing, the reaction forces may be as high as:

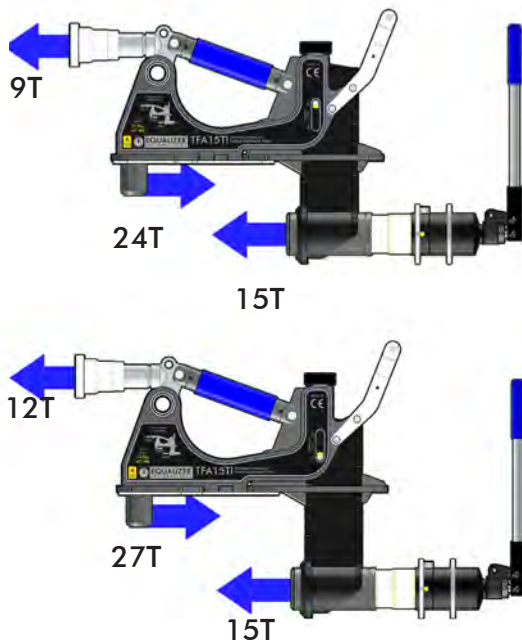

RANGE OF APPLICATION

	DIMENSION	MINIMUM	MAXIMUM
B	Bolt Hole Diameter	45mm	51mm
M	Misalignment	0mm	65mm
R	Rise	150mm	250mm
D	Pipe Leg Drop	83mm	123mm
W	Wing Reach	120mm	160mm
H	Reaction Spacing	200mm	200mm

MINIMUM EXTENSION

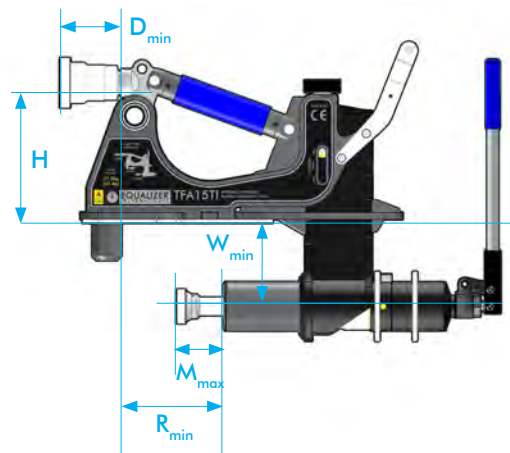

MAXIMUM EXTENSION

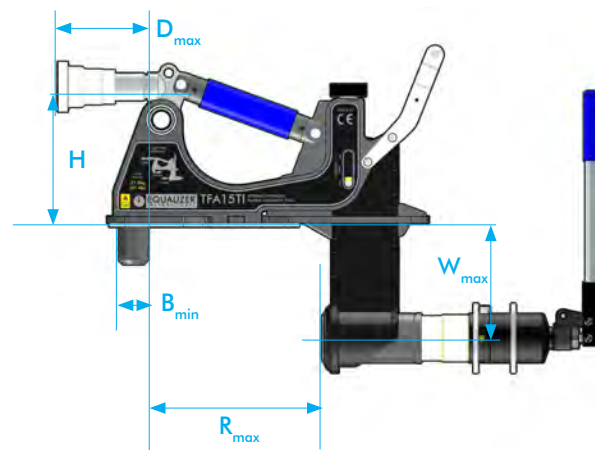

5.2

TFA15TI TOOL FUNCTION

HYDRAULIC TOOL OPERATION

Prior to operation, ensure the air-vent in the integral hand pump is not obstructed. Any obstruction in the air-vent can cause a vacuum in the system which can limit the cylinder's travel.

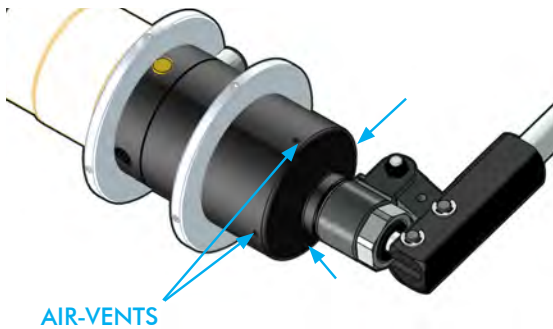

The TFA15TI uses a hydraulic cylinder to advance the Alignment Piston and align the flanges. The hydraulic pressure is applied using the integrated hand pump, enabling accurate control of the force applied.

The integral hand pump has a control lever which allows the user to select advance (+) or retract (-).



ACTUATING THE TFA15TI

Follow the Tool Operation instructions (see Section 3), using the following instructions to actuate the TFA15TI tool.

When advance (+) is selected, pumping the handle will advance the Alignment Piston.



RETRACTING THE TFA15TI

Selecting retract (-) will depressurise the cylinder and cause it to retract under the force of its internal spring. The handle does not need to be pumped to retract the tool.

5.3

TFA15TI KIT CONTENTS

STANDARD KIT

- 1 x TFA15TI Tool
- 1 x Instruction Manual
- 1 x Hard Case

Product Code: TFA15TISTD



5.4

TFA15TI DIMENSIONS

Tool Weight: 21.5kg (47.4lb)

Box Dimensions:

- 585.0mm (23.0")
- 900.0mm (35.4")
- 160.0mm (11.8")

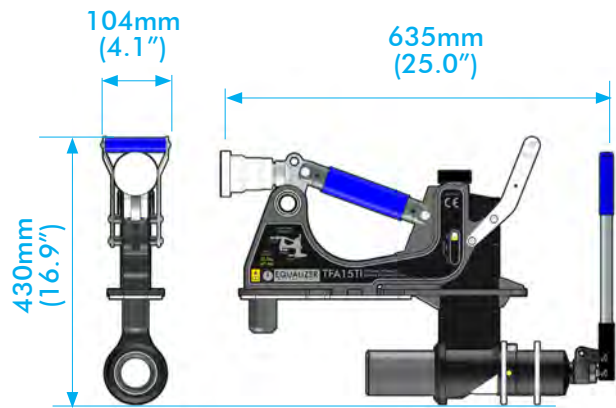

6.

TROUBLESHOOTING

6.1 TFA15TI TROUBLESHOOTING

THE ALIGNMENT PISTON ADVANCES SOME OF THE WAY AND THEN STOPS PROGRESSING

POSSIBLE CAUSE:

- The air-vent is obstructed by dirt or debris.
- The tool has reached its maximum load.

RECOMMENDED ACTION:

- Carefully unblock the air-vent using a small blunt object.

THE ALIGNMENT PISTON DOESN'T MOVE

POSSIBLE CAUSE:

- There is an air-lock within the hydraulic system.

RECOMMENDED ACTION:

- Select Retract (-) and prime pump to circulate oil around the system.

POSSIBLE CAUSE:

- Insufficient oil in the hydraulic system.

RECOMMENDED ACTION:

- Refer to an approved Equalizer distributor for further instruction.

POSSIBLE CAUSE:

- Retract (-) is selected.

RECOMMENDED ACTION:

- Select Advance (+) and pump the handle.

POSSIBLE CAUSE:

- Air has accumulated around pump inlet when used upside down.

RECOMMENDED ACTION:

- Inspect the tool for oil leaks on the reservoir,

possibly indicative of a perished bladder. Refer to an approved Equalizer distributor for repair.

THE ALIGNMENT PISTON MOVES AS INTENDED, BUT DOESN'T SEEM TO BE ACHIEVING FULL PRESSURE WHEN UNDER LOAD

POSSIBLE CAUSE:

- Intermediate valve not seating / relief valve leaking.

RECOMMENDED ACTION:

- Refer to an approved Equalizer distributor for further instruction.

HYDRAULIC PRESSURE SLOWLY DIMINISHES AND THE PUMP HANDLE RISES

POSSIBLE CAUSE:

- The outlet check valve is leaking.

RECOMMENDED ACTION:

- Refer to an approved Equalizer distributor for further instruction.

HYDRAULIC PRESSURE SLOWLY DIMINISHES AND THE PUMP HANDLE DOES NOT RISE

POSSIBLE CAUSE:

- The release valve is leaking.

RECOMMENDED ACTION:

- Refer to an approved Equalizer distributor for further instructions.

POSSIBLE CAUSE:

- The piston seal is leaking.

RECOMMENDED ACTION:

- Inspect the tool for oil leaks, possibly indicative of a perished seal or loose blanking plug. Refer to an approved Equalizer distributor for further instructions.

TOOL ACTUATION FEELS SOFT AND UNRESPONSIVE

POSSIBLE CAUSE:

- There is air in the hydraulic system.

RECOMMENDED ACTION:

- Refer to an approved Equalizer distributor for further instruction.

7.

REGULATORY INFORMATION

7.1

REGISTERED HEAD OFFICE

EQUALIZER INTERNATIONAL LTD.
Equalizer House
Claymore Drive
Aberdeen
Scotland
AB23 8GD

7.2

APPLICABLE PATENT NUMBERS

The following list of Patents are applicable to EQUALIZER INTERNATIONAL LTD TFA15TE and TFA15TI tools:

REGISTERED PATENTS

- 5832582
- AU690191
- NO319697
- 6327763
- 318535
- 0916051B

8.

PARTS LISTS & SERVICE KITS

TFA15TI PARTS LIST

270000-01 REV.01

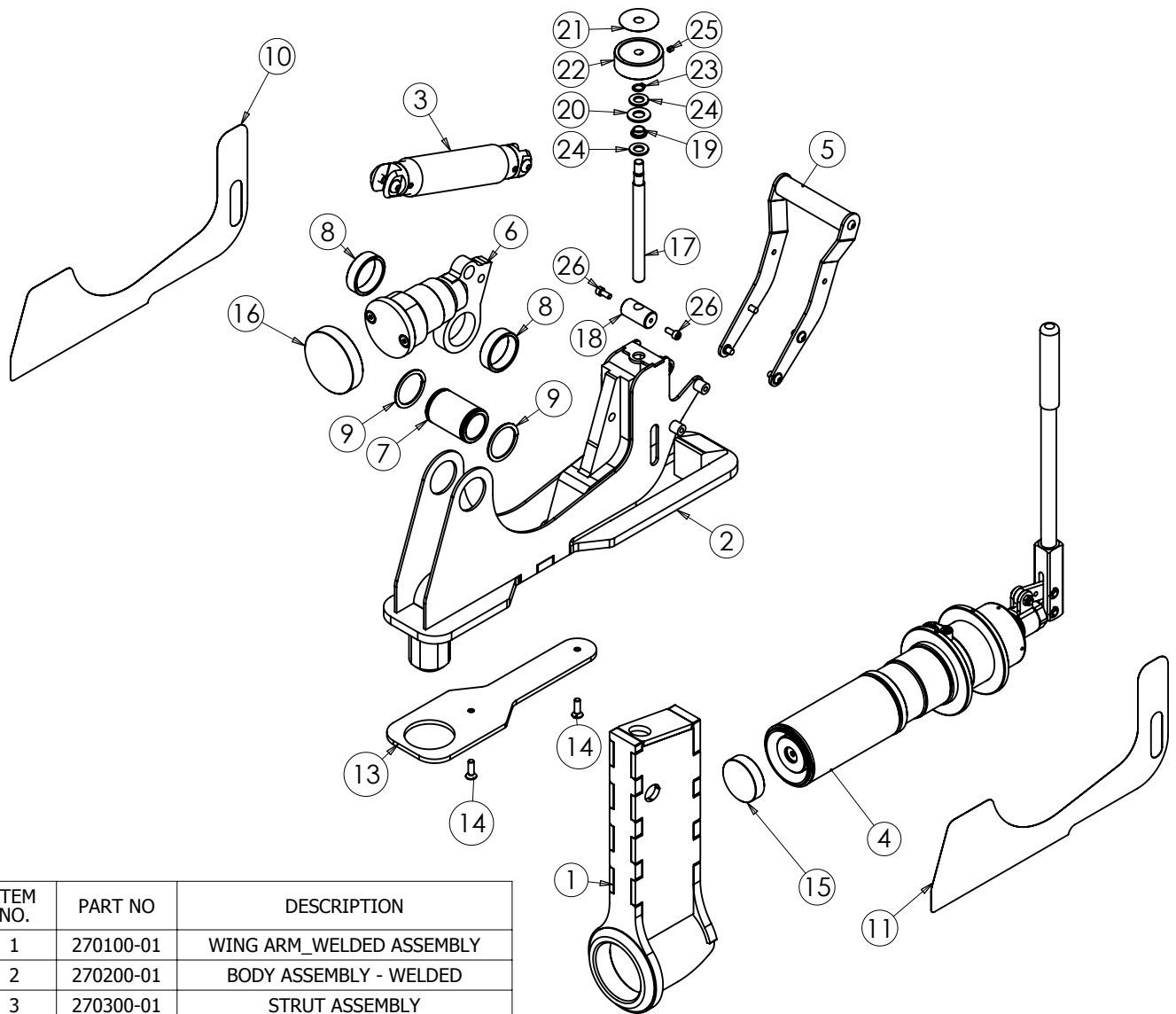

ITEM NO.	PART NO	DESCRIPTION
1	270100-01	WING ARM_WELDED ASSEMBLY
2	270200-01	BODY ASSEMBLY - WELDED
3	270300-01	STRUT ASSEMBLY
4	270500-01	CYLINDER ASSEMBLY
5	271300-01	HANDLE ASSEMBLY
6	270400-01	ADJUSTABLE LEG ASS
7	270900-01	ADJUSTMENT LEG FIXING SHAFT
8	272000-01	SIDE SPACER BUSH
9	270800-01	SPIRAL CLIP
10	070393-01	RHS STICKER
11	070392-01	LHS STICKER
13	KIT 271400-01	PROTECTION PAD
14		M6 CSK HEX SCREW
15		FOOT CAP FLANGE
16		FOOT CAP TOWER
17	KIT 271500-01	ADJUSTMENT ROD
18		ADJUSTER BOSS
19		ADJUSTMENT BUSH
20		ADJUSTMENT BUSH WASHER
21		WING ADJUST DECAL_TFA15TI
22		RELEASE KNOB
23		10MM EXTERNAL CIRCLIP
24		WASHER 10mm ID
25		M5 SCKT SET SCREW
26		M5x12mm SCKT HEAD CPSCREW

TFA15TI CYLINDER ASSEMBLY PARTS LIST

270500-01 REV.01

ITEM NO.	PART NO	DESCRIPTION	QTY/ASS
1	840300-01	H.CYLINDER & PUMP TI ASSEMBLY	1
2	270600-01	CYLINDER FOOT ASSEMBLY	1
3	270701-01	CYLINDER ADJUSTING RING	2
4	270501-01	TI CYLINDER SLEEVE	1
5	KIT 271900-01	SPIRAL RETAINING RING	2
6		M6 SCKT SET SCREW	1
7		M5 SCKT SET SCREW	4

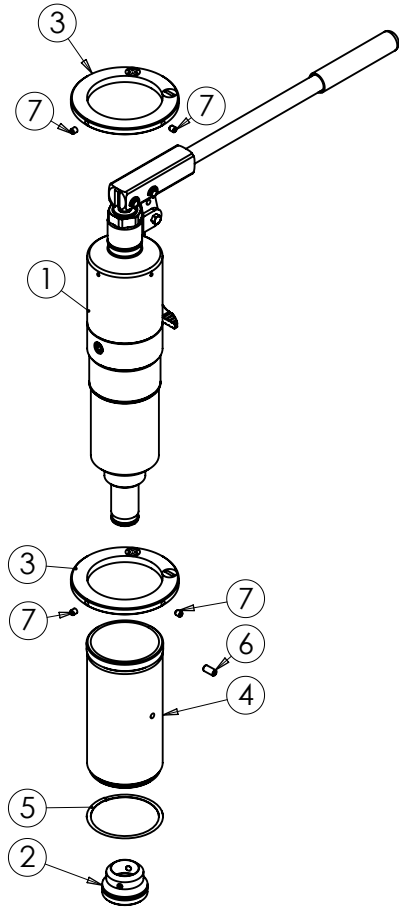

TI CYLINDER PARTS LIST

840300-01 REV.02

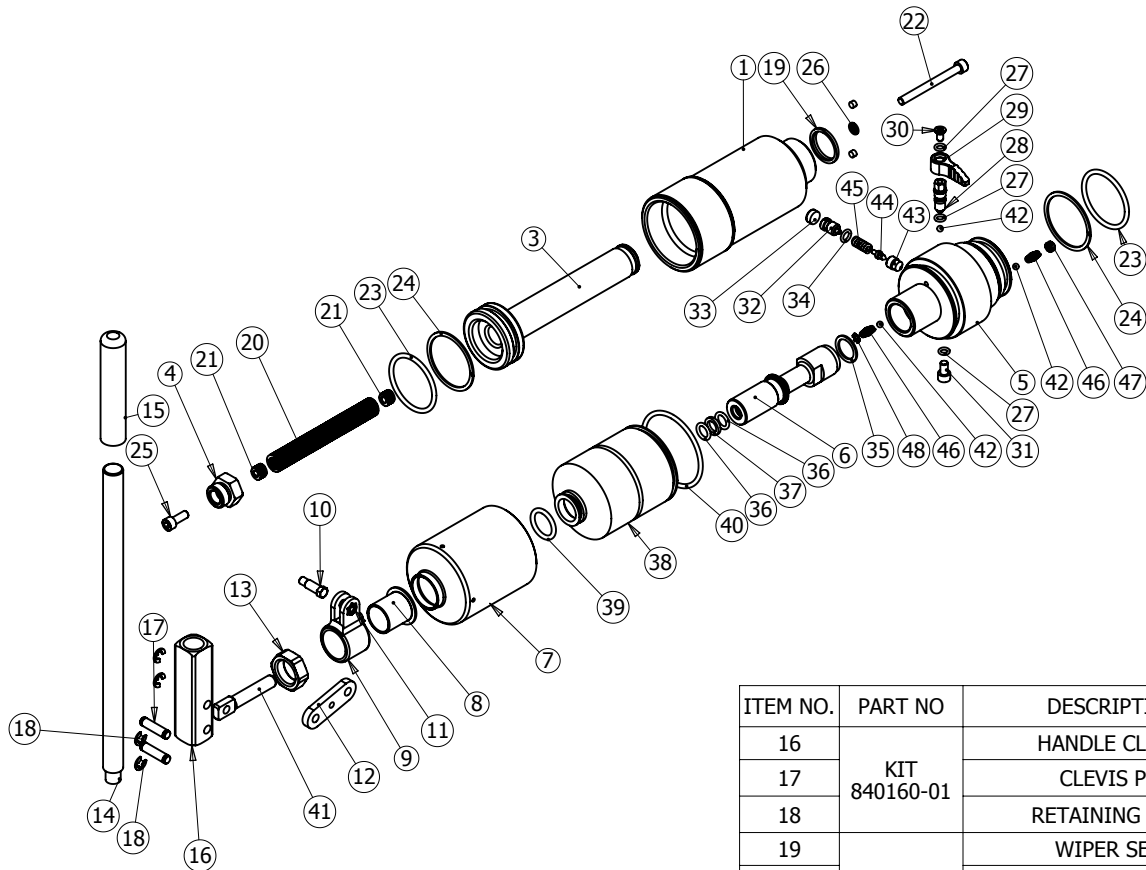

ITEM NO.	PART NO	DESCRIPTION	QTY.
1	830301-01	CYLINDER BODY	1
2	830310-01	CYL VENT PLUG	2
3	830302-01	PISTON	1
4	840100-01	NUT	1
5	840301-01	CYLINDER BASE	1
6	376901-01	PUMP PISTON HOUSING	1
7	840302-01	BLADDER HOUSING	1
8	372401-01	PISTON HOUSING CAP	1
9	372501-01	SWIVEL CLEVIS	1
10	373201-01	CLEVIS SCREW	1
11	373301-01	ANTI-LOOSEN NUT	1
12	373101-01	LINK CONNECTOR	1
13	372601-01	RETAINING NUT	1
14	373401-01	HANDLE ROD	1
15	306502-01	HANDLE GRIP	1

ITEM NO.	PART NO	DESCRIPTION	QTY.
16		HANDLE CLEVIS	1
17	KIT 840160-01	CLEVIS PIN	2
18		RETAINING RING	4
19		WIPER SEAL	1
20		TENSION DIE SPRING	1
21		SPRING LOCK	2
22	KIT 840110-01	M6 CAPSCREW	1
23		O-RING	2
24		BACK-UP RING	2
25		SCREW	1
26		M6 GASKET SEAL	1
27		O-RING	3
28		RELIEF VALVE SCREW	1
29		RELIEF VALVE KNOB	1
30		FIXING SCREW	1
31		OIL FILL SCREW	1
32		OVERLOAD COVER SCREW	1
33		CAP	1
34	KIT 840120-01	O-RING	1
35		WASHER	1
36		O-RING	2
37		BACK UP RING	1
38		RESERVOIR BLADDER	1
39		O-RING	1
40		O-RING	1
41		PUMP PISTON ROD	1
42		STEEL BALL	1
43		STEEL BALL	2
44		CONE SEAT	1
45		CONE	1
46	KIT 375020-01	LONG SEPARATOR SPRING	1
47		SPRING	2
48		SCREW	1
49		SPRING LOCK	1

STRUT ASSEMBLY PARTS LIST

270300-01 REV.01

ITEM NO.	PART NO	DESCRIPTION	QTY/ASS
1	270301-09	STRUT TUBE	1
2	270302-09	CLEVIS	2
3	KIT 271600-01	M8 BUTTON HEX SCREW	4
4		FOAM GRIP - 34MM X 135MM	1
5		6MM ROLL PIN	2

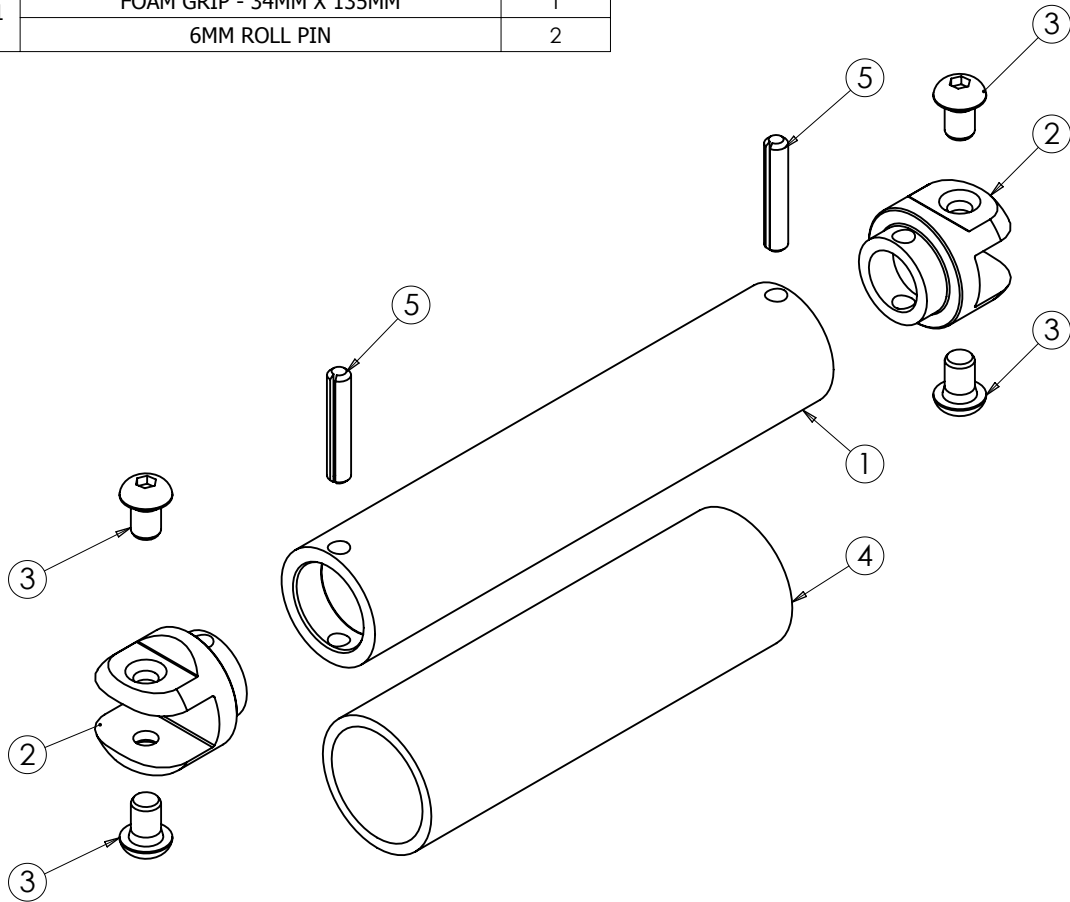

SAFETY BOND ASSEMBLY PARTS LIST

270800-01 REV.01

ITEM NO.	PART NO	DESCRIPTION	QTY/ASS
1	270800-01	SAFETY BOND ASSEMBLY	1

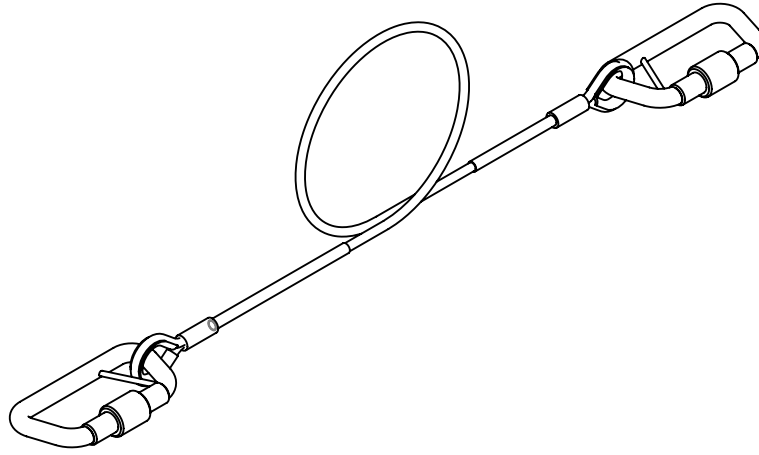

HANDLE ASSEMBLY PARTS LIST

271300-01 REV.01

ITEM NO.	PART NO	DESCRIPTION	QTY/ASS
1	501301-01	HANDLE BAR	1
2	501101-01	HANDLE LEFT	1
3	501201-01	HANDLE RIGHT	1
4	KIT 271800-01	BLUE HANDLE SLEEVE	1
5		WASHER (0.8MM)	6
6		SCREW FOR HANDLE	6
7		SPACER	2

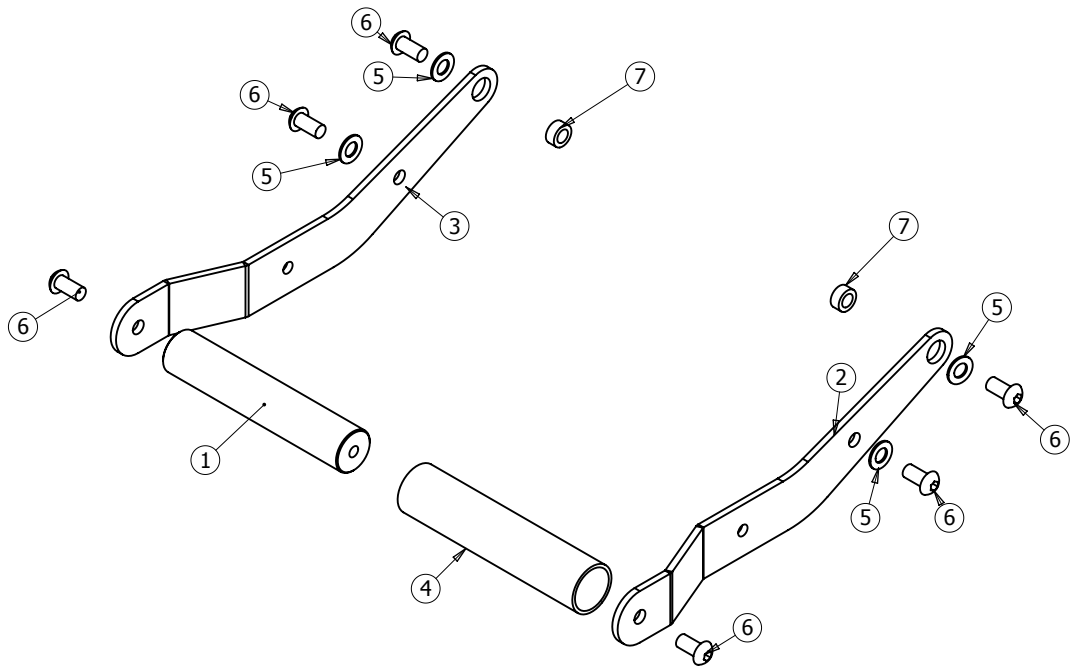

ADJUSTMENT LEG ASSEMBLY PARTS LIST

270400-01 REV.01

ITEM NO.	PART NO	DESCRIPTION	QTY/ASS
1	270401-01	CLEVIS WELDED ASSEMBLY	1
2	270402-01	ADJUSTMENT FOOT	1
3		ADJUSTMENT FOOT PAD	1
4	KIT 271700-01	SPIRAL CLIP	1
5		M6 CSK HEX SCREW	2

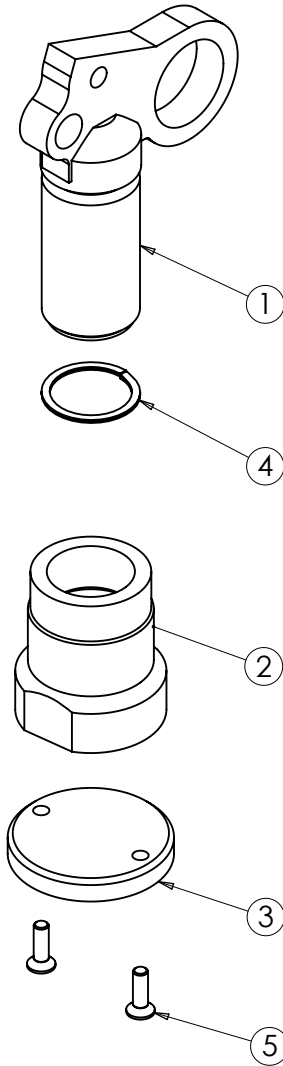

PROTECTIVE PAD SERVICE KIT

271400-01 REV.01

ITEM NO.	DESCRIPTION	QTY/ASS
1	M6 CSK HEX SCREW	2
2	FOOT CAP TOWER	1
3	FOOT CAP FLANGE	1
4	PROTECTION PAD	1

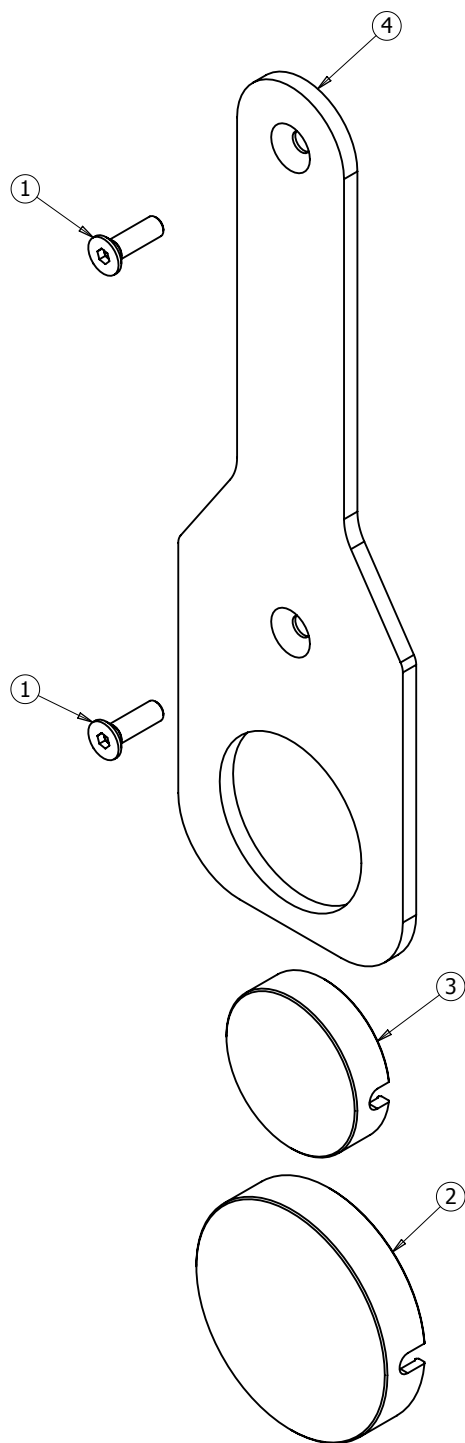

WING ADJUSTMENT SERVICE KIT

271500-01 REV.01

ITEM NO.	DESCRIPTION	QTY/ASS
1	ADJUSTMENT ROD	1
2	ADJUSTER BOSS	1
3	ADJUSTMENT BUSH	1
4	ADJUSTMENT BUSH WASHER	1
5	WING ADJUST DECAL_TFA15TI	1
6	RELEASE KNOB	1
7	10MM EXTERNAL CIRCLIP	1
8	WASHER 10mm ID	2
9	M5 SCKT SET SCREW	4
10	M5x12mm SCKT HEAD CPSCREW	2

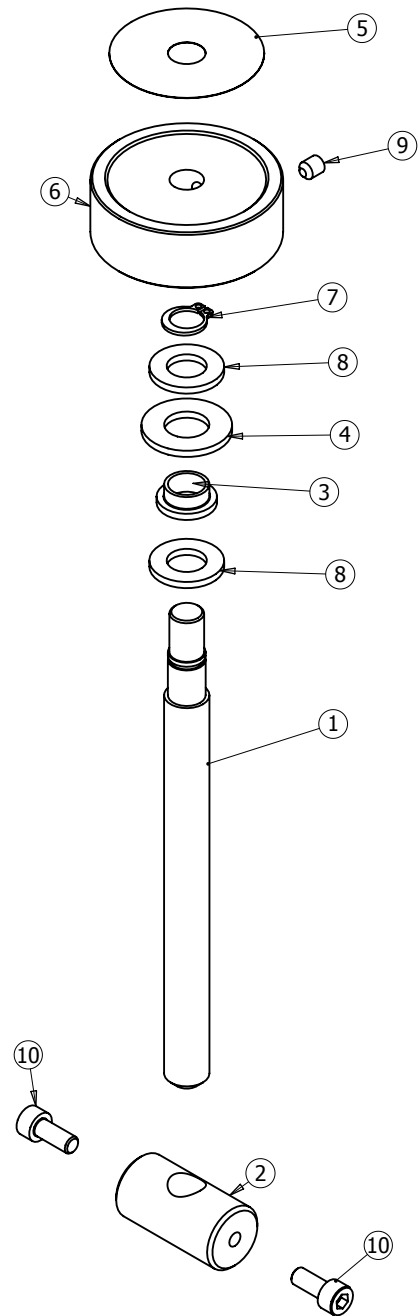

CLEVIS SERVICE KIT

840160-01 REV.01

ITEM NO.	DESCRIPTION	QTY
1	HANDLE CLEVIS	1
2	CLEVIS PIN	2
3	RETAINING RING	4

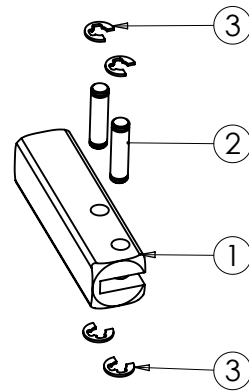

INTEGRAL MANIFOLD SERVICE KIT

375020-01 REV.01

ITEM NO.	DESCRIPTION	QTY.
1	STEEL BALL	2
2	CONE SEAT	1
3	CONE	1
4	LONG SEPARATOR SPRING	1
5	SPRING	2
6	SCREW	1
7	SPRING LOCK	1

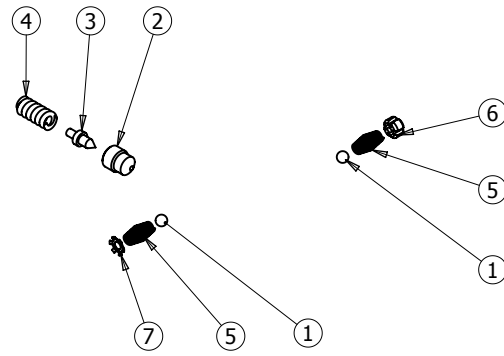

INTEGRAL BLADDER SERVICE KIT

840120-01 REV.02

ITEM NO.	DESCRIPTION	QTY.
1	STEEL BALL	1
2	O-RING	3
3	RELIEF VALVE SCREW	1
4	RELIEF VALVE KNOB	1
5	FIXING SCREW	1
6	OIL FILL SCREW	1
7	OVERLOAD COVER SCREW	1
8	CAP	1
9	O-RING	1
10	WASHER	1
11	O-RING	2
12	BACK UP RING	1
13	O-RING	1
14	PUMP PISTON ROD	1
15	RESERVOIR BLADDER	1
16	O-RING	1

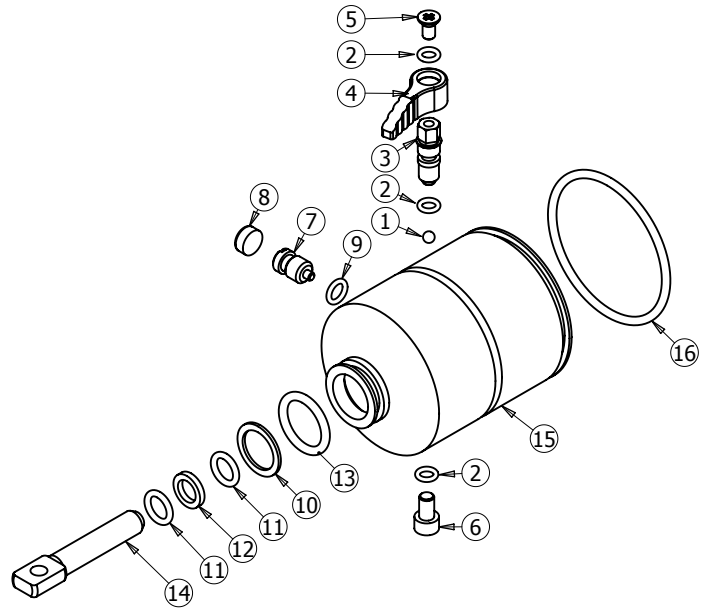

CYLINDER SERVICE KIT

840110-01 REV.02

ITEM NO.	DESCRIPTION	QTY.
1	WIPER SEAL	1
2	TENSION DIE SPRING	1
3	SPRING LOCK	2
4	M6 CAPSCREW	1
5	O-RING	2
6	BACK-UP RING	2
7	SCREW	1
8	M6 GASKET SEAL	1

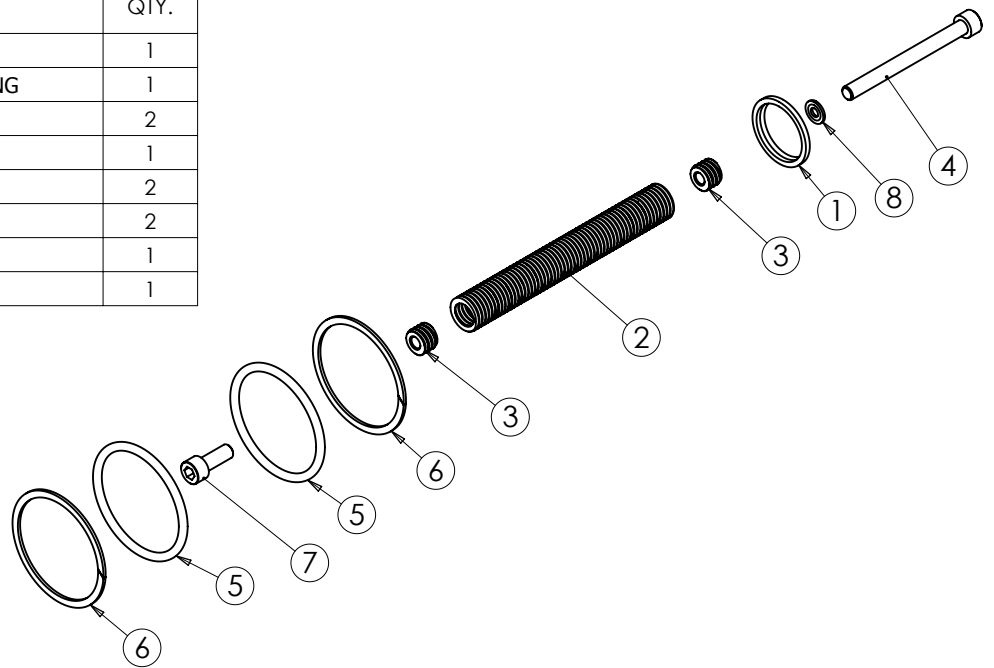



EQUALIZER INTERNATIONAL LTD.

**Head Office
Equalizer House
Claymore Drive
Aberdeen
Scotland
UK**

**AB23 8GD
t: +44 (0) 1224 701970
f: +44 (0) 1224 823791**

**Houston Office
1330 Yale Street
Houston TX 77008
USA**

t: +1 (713) 927-1840

www.equalizerinternational.com