



FLANGE TOOL INNOVATION

PRODUCT DATA SHEET

TFA15TI INTEGRAL HYDRAULIC FLANGE ALIGNMENT TOOL

ALIGNING FORCE:
15T

TOOL WEIGHT
21.5kg (48.5lb)

KIT COMPONENTS

- 1 x TFA15TI Tool
- 1 x Instruction Manual
- 1 x Hard Case

Product Code: TFA15TISTD



REACTION FORCES

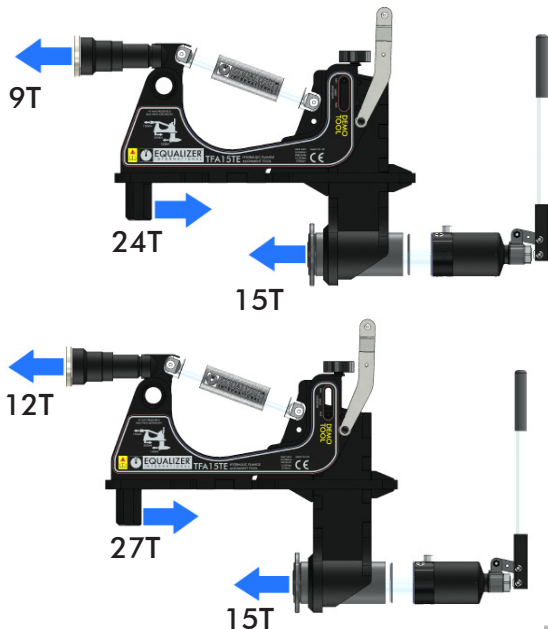

WEIGHTS AND DIMENSIONS

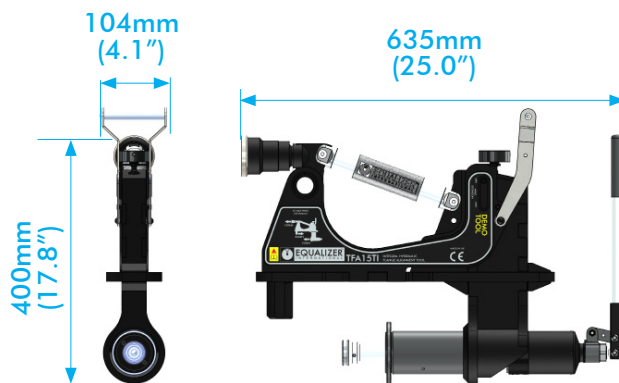

Box Dimensions:
585.0mm (23.0")
900.0mm (35.4")
170.0mm (11.8")

Tool Weight:
21.5kg (48.5lb)

info@equalizerinternational.com
www.equalizerinternational.com

TFA15TI

INTEGRAL HYDRAULIC FLANGE ALIGNMENT TOOL



FLANGE TOOL INNOVATION

RANGE OF APPLICATION

MINIMUM EXTENSION

MAXIMUM EXTENSION

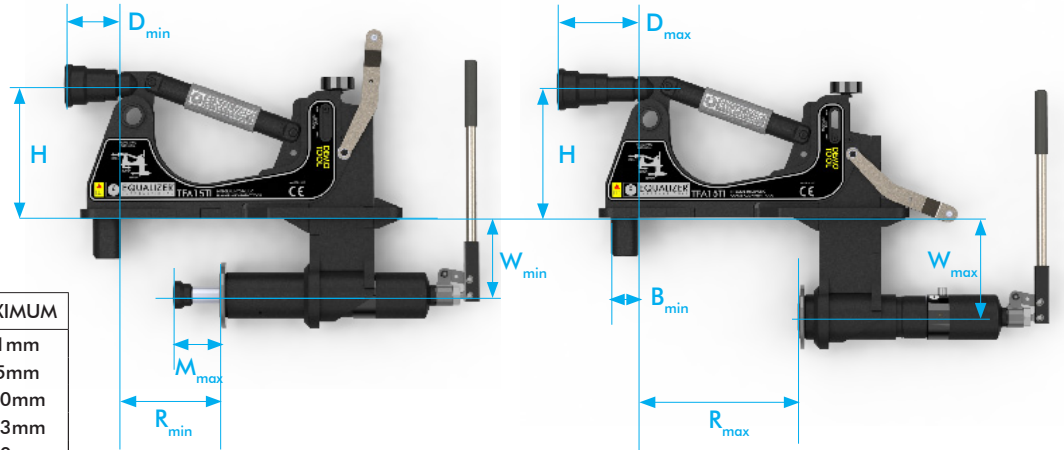

	DIMENSION	MINIMUM	MAXIMUM
B	Bolt Hole Diameter	45mm	51mm
M	Misalignment	0mm	65mm
R	Rise	150mm	250mm
D	Pipe Leg Drop	83mm	123mm
W	Wing Reach	120mm	160mm
H	Reaction Spacing	200mm	200mm

