



FA1™

FLANGE ALIGNMENT TOOL

Operator Instruction Manual



EQUALIZER[™]
INTERNATIONAL



info@equalizerinternational.com
www.equalizerinternational.com

INNOVATION IN ITS MOST FUNCTIONAL FORM

INDEX

SECTION	CONTENTS	PAGE NO.
1	INTRODUCTION	2
2	SAFETY INFORMATION	2 - 3
3	TECHNICAL DATA	4
	3.1 KIT COMPONENTS	4
	3.2 HOW THE FA1TM WORKS	
4	FLANGE MISALIGNMENT DETERMINATION PROCEDURE	5
	4.1 LATERAL MISALIGNMENT	5
5	FA1TM MECHANICAL FIXED FLANGE & ROTATIONAL ALIGNMENT TOOL	
	5.1 INSTALLATION & OPERATION	6 - 7
	5.2 EXAMINATION & STORAGE	8
	5.3 MAINTAINANCE	8
	5.4 PARTS LIST	9
	5.5 WEIGHTS & DIMENSIONS	10
	5.6 TROUBLESHOOTING	11
	5.7 APPLICATION DIMENSIONS	11
6	RANGE OF APPLICATION	
	6.1 BS10, API6BX UND API6B FLANGE TABLES	12
	6.2 ASME B16.5, B16.47 AND DIN WELD NECK FLANGE TABLES	13
	6.3 SPO FLANGE TABLE	14

1. INTRODUCTION

The Equalizer FA1™ TOOL is an aid of use in normal maintenance and installation procedures to enable the realignment of misaligned flanges within respective working capacities. For example, the tool can be used to assist in the replacement of ring and other types of flange joint. The use of these instructions will promote safe use, and maximise the service life of the tools.

2. SAFETY INFORMATION

The operator MUST read this manual prior to using the tools.

Failure to comply with the following cautions and warnings could cause equipment damage and personal injury; read the manual fully!

Read all the following instruction, warnings and cautions carefully. Follow all safety precautions to avoid personal injury or property damage during system operation.

Equalizer International Ltd cannot be responsible for damage or injury resulting from unsafe product use, lack of maintenance or incorrect product and/or system operation. Contact Equalizer International Ltd when in doubt as to the safety precautions and applications.

Only people competent in the use of mechanical and hydraulic equipment should use these tools.

In all installations the site safety requirements must be adhered to. ALSO the safety of the operator, and when present, any assisting personnel, is of paramount importance along with the safety of others including, when present, the general public.

These instructions are only to cover the safe operation of THE EQUALIZER FA1™ FLANGE ALIGNMENT TOOL, during normal maintenance/installation operations.

All other safety aspects must be controlled by the operation supervisor.

A **CAUTION** is used to indicate correct operating or maintenance procedures and practices to prevent damage to, or destruction of equipment or other property.

A **WARNING** indicates a potential danger that requires correct procedures or practices to avoid personal injury.

A **DANGER** is only used when your action or lack of action may cause serious injury or even death.



IMPORTANT: Operator must be competent in the use of hydraulic equipment. The operator must have read and understood all instructions, safety issues, cautions and warnings before starting to operate the Equalizer equipment.



WARNING: To avoid personal injury and possible equipment damage, make sure all hydraulic components are rated to a safe working pressure of 700bar (10,000psi)



WARNING: Do not overload equipment. Overloading causes equipment failure and possible personal injury. The risk overloading can be avoided by using the Equalizer Hand Pump, which has its safety valve set to 700bar by the factory. If alternative pumps are used, ensure they are rated at a safe working pressure 700bar (10,000psi)



CAUTION: Make sure that all system components are protected from external sources of damage, such as excessive heat, flame, moving machine parts, sharp edges and corrosive chemicals.



CAUTION: Avoid sharp bends and kinks that will cause severe back-up pressure in hoses. Bends and kinks lead to premature hose failure. Do not drop heavy objects onto hoses. A sharp impact may cause internal damage to hose wire strands; applying pressure to a damaged hose may cause it to rupture. Do not place heavy weights on the hoses, or allow vehicle to roll over the hoses; crush damage will lead to premature hose failure.



WARNING: Immediately replace worn or damaged parts with genuine Equalizer parts. Equalizer parts are designed to fit properly and withstand rated loads. For repair or maintenance service contact your Equalizer distributor or service centre.



DANGER: To avoid personal injury keep hands and feet away from the tool and workpiece during operation.



WARNING: Always wear suitable clothing and Personal Protective Equipment (PPE)



DANGER: Do not handle pressurised hoses. Escaping oil under pressure can penetrate the skin, causing serious injury. If oil is injected under the skin, seek medical attention immediately.



WARNING: Never pressurize unconnected couplers. Only use hydraulic equipment in a connected system.



IMPORTANT: Do not lift hydraulic equipment by the hoses or couplers. Use the carrying handle or other means of safe transport.



CAUTION: Do not operate the equipment without lubricating all moving parts as in section 5.4, 6.4 & 7.4. Use only high pressure molybdenum disulphide grease.

3. TECHNICAL DATA

	Tool Description	Aligning Force
FA1TM	Mechanical Fixed Flange Alignment Tool	1.0 T (10kN)

3.1 KIT COMPONENTS

- 1 x FA1TM Tool
- 1 x Ratchet & Strap
- 1 x Instruction Manual



Product Code: FA1TMSTD

3.2 HOW THE FA1TM WORKS

1. The FA1TM is secured to the lower of the two flanges by fully inserting the lift hook into the bolt-hole at the point of greatest misalignment.
2. The drop leg thumb screw is slacked and the drop leg is adjusted down to the pipe while the tool is held level in the bolt-hole.
3. The drop leg thumb screw is then tightened until firm.
4. The strap and ratchet are attached to the drop leg and around the pipe for added security.
5. The screw handle is then turned clockwise until the driven wedge comes into contact with the circumference of the opposite flange.

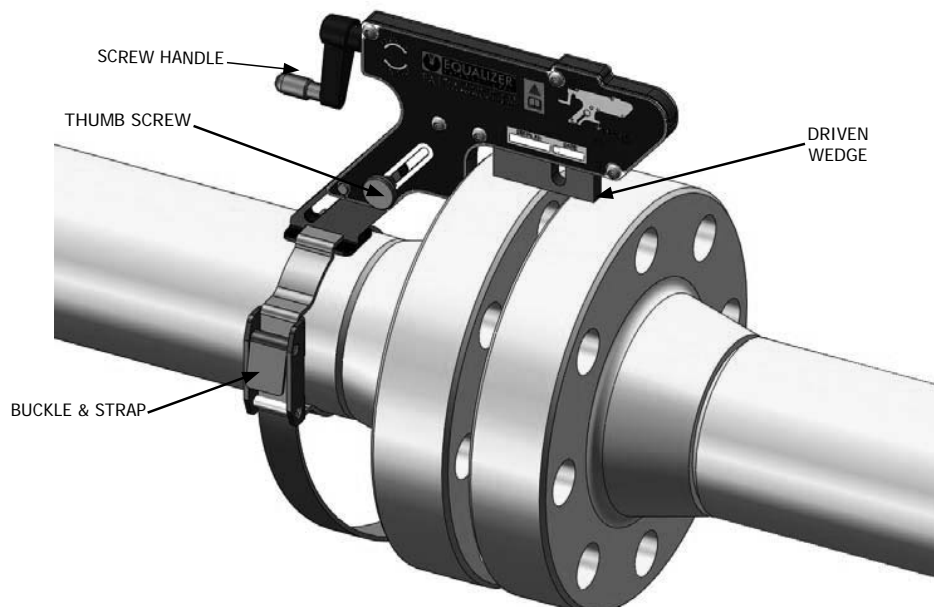

4. FLANGE MISALIGNMENT DETERMINATION

The tool being used must not be attached to a flanged joint prior to the misalignment procedure being carried out.

4.1 LATERAL MISALIGNMENT

1. Loosen and remove every second bolt around the flange, continue with this until misalignment occurs.

A flange joint, once broken down, may spring out of alignment at any point, or in any direction around its circumference. Misalignment may not occur until only a few bolts remain.

2. At this point the direction of any misalignment should become obvious. The alignment tool being used should be attached at the maximum point misalignment (point A or point B in the examples shown below) as shown in sections 5.3, 6.3 & 7.3.

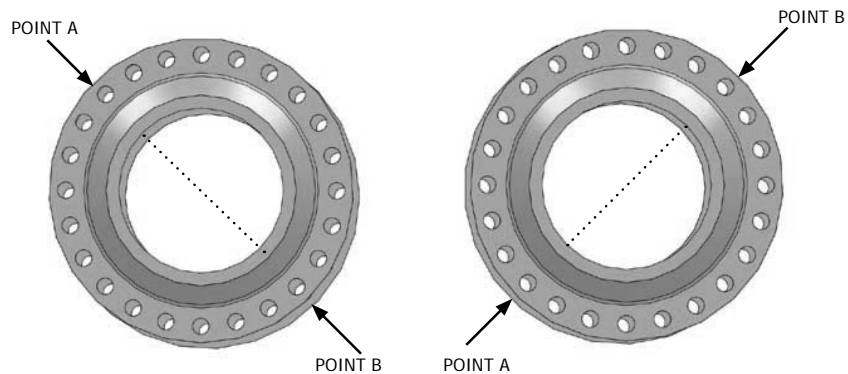

5. FA1™ MECHANICAL FIXED FLANGE ALIGNMENT TOOL

5.1 INSTALLATION AND OPERATION

1. Carry out the Flange Misalignment Determination Procedure (see section 4) to determine the points of maximum misalignment.

In this example, the points of maximum misalignment are at the top and bottom of the joint.

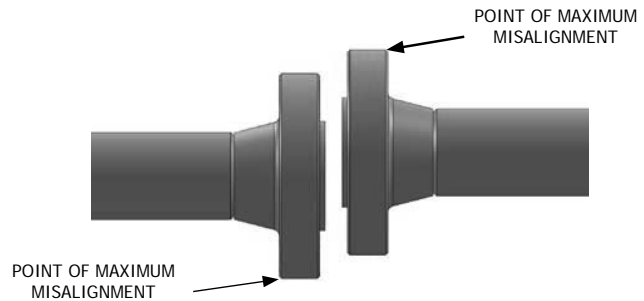

2. Guide the lift hook into the bolt-hole at the point of maximum misalignment.

Adjust the drop leg down onto the pipe by slackening the thumb screw in an anticlockwise direction.

The tool should be held up level within the bolt-hole during adjustment.

NB: The tool must be parallel to pipe during operation.

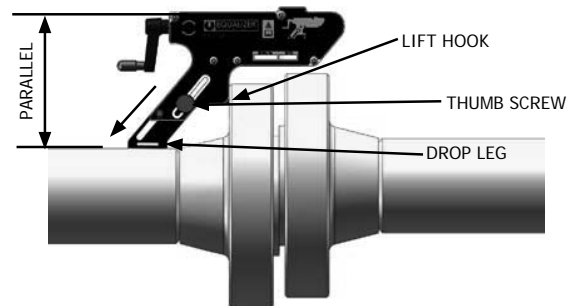

3. Rotate the screw handle clockwise until the driven wedge makes contact with the opposite flange.

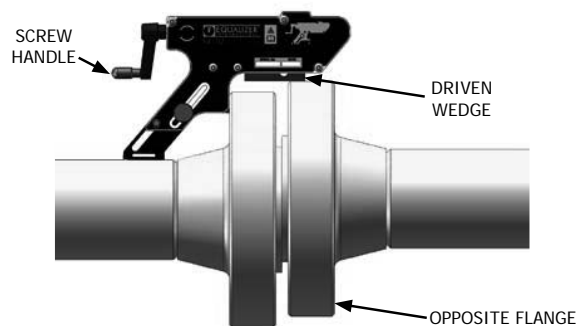

4. Thread the strap through the aperture on the base of the drop leg as shown.

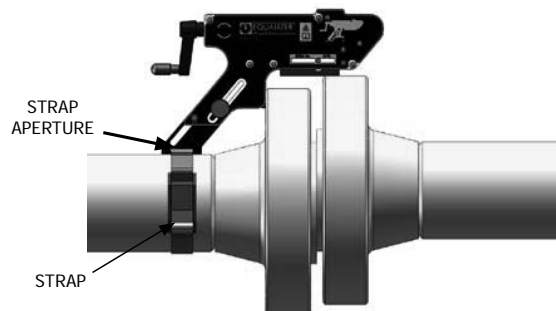

5. Feed the open end of the strap through the buckle mechanism as shown. Close the clasp to secure strap.

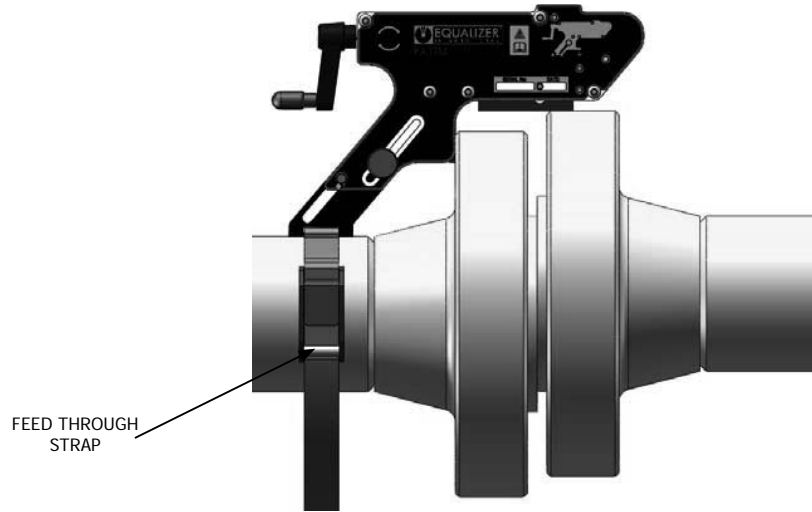

6. Now that everything is secured, rotate the handle clockwise to apply pressure to the circumference of the opposite flange & bring the flange joint in alignment.

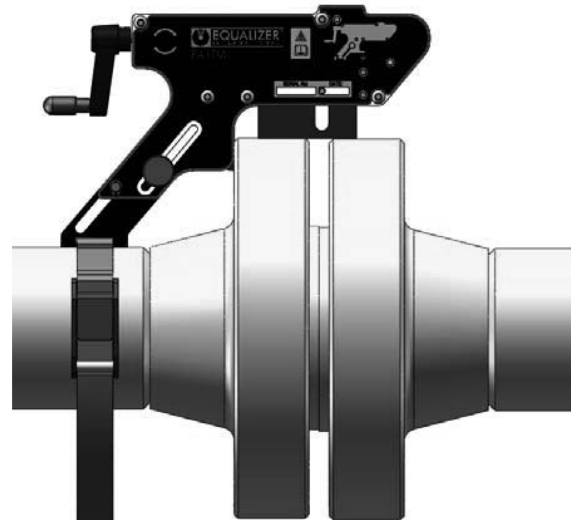
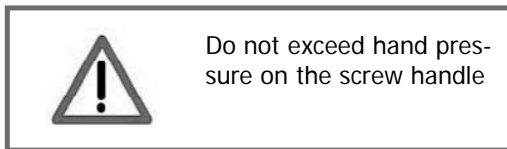

7. Once in alignment the bolts may be inserted and tightened. After replacing all of the bolts (apart from the bolt which will go into the bolt-hole in which the FA1™ is located) remove the tool by reversing steps 2-6. Insert the last bolt and tighten.

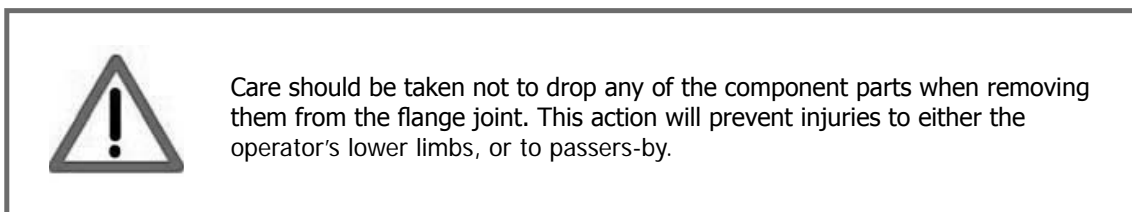

5.2 EXAMINATION & STORAGE

- 1 On return from each job before allocation against subsequent work, the completeness of the Equalizer FA1™ kit must be established and items examined to ensure that they are serviceable.
- 2 Any missing or damaged items are to be replaced as soon as possible and prior to the tool being used again.
- 3 Store the FA1™ in a cool, dry place and ensure all machined surfaces are greased.
- 4 Ensure wedges, pins and legs remain grit free and that parts move freely.

5.3 MAINTENANCE

- 1 Secure the tool upright on a bench.
- 2 Using a small flat screwdriver, lever out one circlip and unscrew 5 x 4mm hex screws.
- 3 Remove cover plate and remove any dirt or corrosion from moving parts.
- 4 Inspect components for wear and damage, replace if necessary! If there is no damage present, then they can be greased and re-assembled by reversing steps 1-4.

Recommended grease –
Rocol Sapphire Hi-Load or equivalent good quality hi load bearing grease.

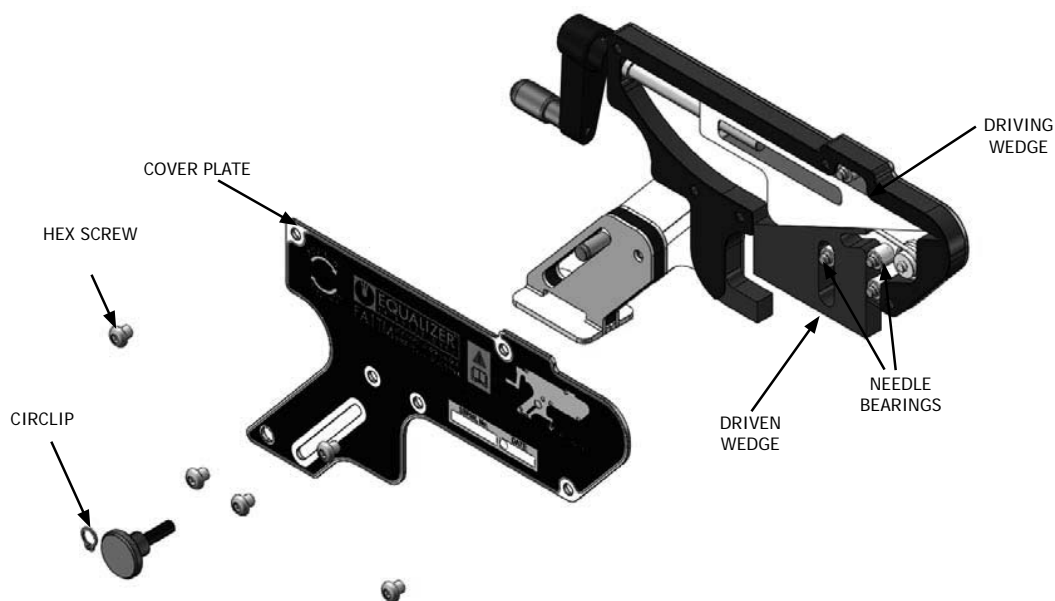

5.4 PARTS LIST

NO.	PART NO	DESCRIPTION	QTY.
1	070280-01	BODY PLATE STICKER LEFT	1
2	070281-01	BODY PLATE STICKER RIGHT	1
3	210100-01	DRIVING WEDGE	1
4	210200-01	BODY FRAME	1
5	210300-01	DRIVEN WEDGE	1
6	210400-01	DRIVE SCREW	1
7	210500-01	COVER PLATE LEFT	1
8	210501-01	COVER PLATE RIGHT	1
9	210600-01	CRANK HANDLE	1
10	210700-01	SPRING PIN	1
11	210800-01	TORSION SPRING	1
12	210900-01	NEEDLE BEARING	4
13	211100-01	BEARING SHAFT	4
14	211200-01	SPRING MANDREL	1
15	211300-01	M6 x 8mm Socket Fl. Screw	10
16	211600-01	DISTANCE PLATE	1
17	211800-01	DROP LEG	1
18	211900-01	LEG PIN 8mm	1
19	212000-01	SPRING RING 8mm	2
20	212200-01	LEG PLASTIC INSERT	1
21	230203-01	M6 RELEASE KNOB	1
22	771801-01	M6 HEX NUT	1
23	220800-01	RATCHET STRAP	1

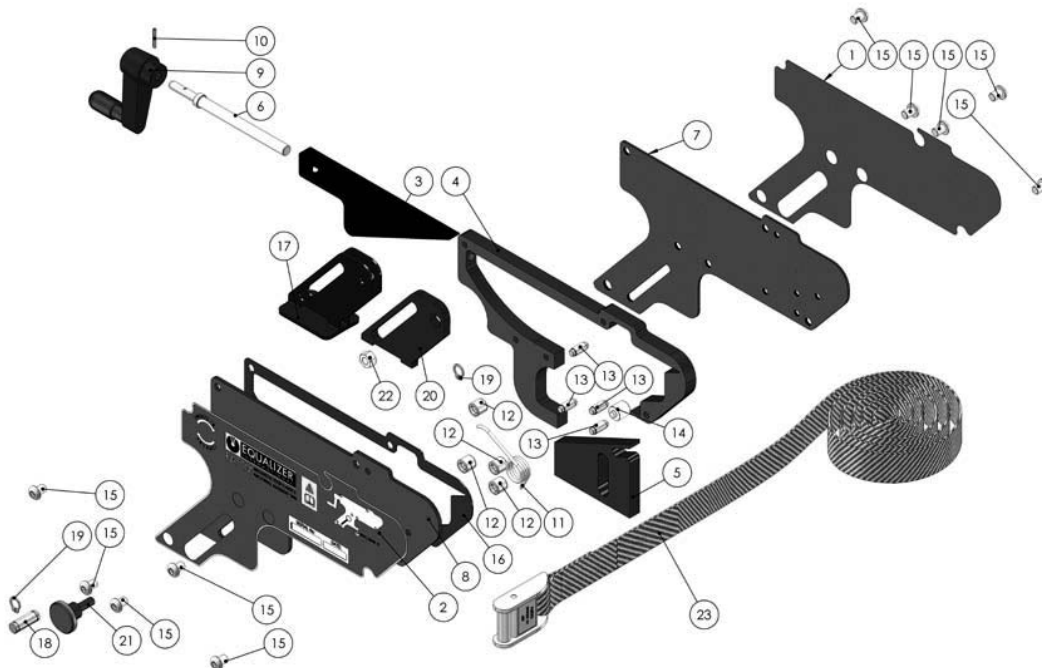

5.5 WEIGHTS & DIMENSIONS

WEIGHTS

Tool only = 1,6 kg (18,96 lbs)
 Ratchet & strap = 0,28 kg (0,62 lbs)

GROSS KIT WEIGHT = 8,88 kg (19,58 lbs)

DIMENSIONS

MINIMUM EXTENSION



MAXIMUM EXTENSION

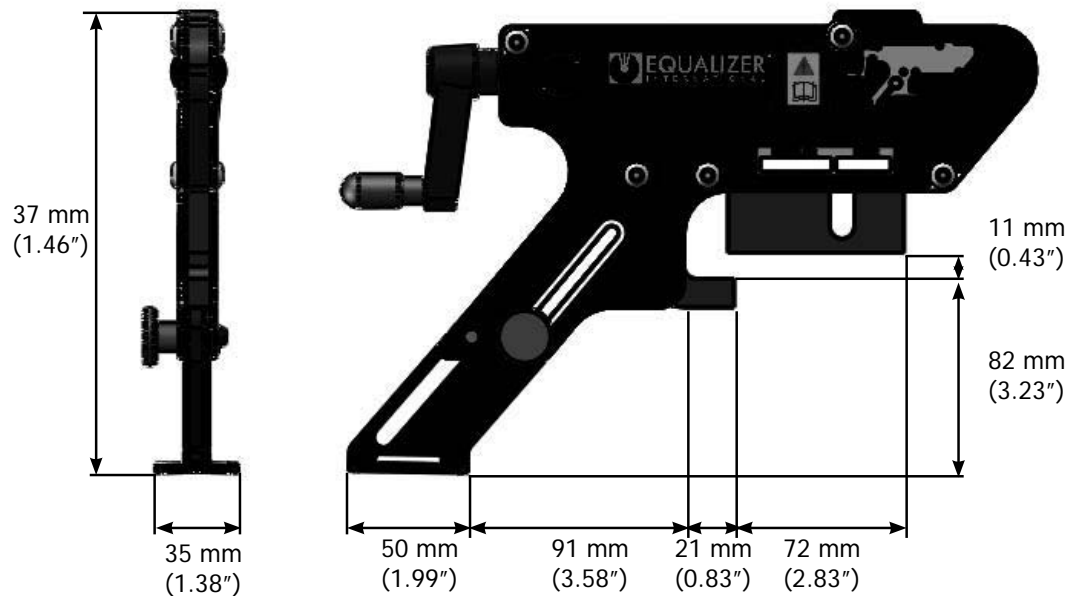

5.6 TROUBLESHOOTING

Problem: The tool is attached and appears to be functioning properly, but the joint will not align

There may be something restricting the joining from aligning.

Check the area around the joint to establish if there is an obstruction to the joint.

The joint may require more than 1.0 t (10 kN), force to align.

If the joint requires more force than that of the 1.0 T (10kN) tool, attach a second tool or another method of aligning should be adapted.

5.7 APPLICATION DIMENSIONS

MINIMUM AND MAXIMUM FLANGE SIZES

Dimension A: must be between 14 and 82mm (0.55" and 3.29").

Dimension B: bolt-hole diameter must be 16mm (0.63") or greater

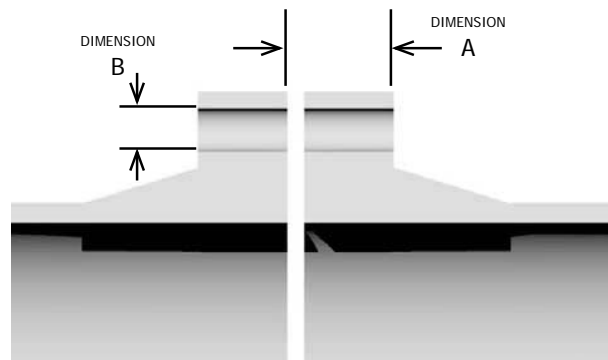

6.2 ASME B16.5 FLANGE RANGE OF APPLICATION

CLASS 150	TOOL		FA41TM																
NPS	3/4"	1"	1 1/4"	1 1/2"	2"	2 1/2"	3"	3 1/2"	4"	5"	6"	8"	10"	12"	14"	16"	18"	20"	24"
NPS	3/4"	1"	1 1/4"	1 1/2"	2"	2 1/2"	3"	3 1/2"	4"	5"	6"	8"	10"	12"	14"	16"	18"	20"	24"
TOOL	FA1TM		FA41TM																
CLASS 300	TOOL		FA41TM																
NPS	3/4"	1"	1 1/4"	1 1/2"	2"	2 1/2"	3"	3 1/2"	4"	5"	6"	8"	10"	12"	14"	16"	18"	20"	24"
NPS	3/4"	1"	1 1/4"	1 1/2"	2"	2 1/2"	3"	3 1/2"	4"	5"	6"	8"	10"	12"	14"	16"	18"	20"	24"
TOOL	FA1TM		FA41TM																
CLASS 400	TOOL		FA41TM																
NPS	3/4"	1"	1 1/4"	1 1/2"	2"	2 1/2"	3"	3 1/2"	4"	5"	6"	8"	10"	12"	14"	16"	18"	20"	24"
NPS	3/4"	1"	1 1/4"	1 1/2"	2"	2 1/2"	3"	3 1/2"	4"	5"	6"	8"	10"	12"	14"	16"	18"	20"	24"
TOOL	FA1TM		FA41TM																
CLASS 600	TOOL		FA41TM																
NPS	1/2"	3/4"	1"	1 1/4"	1 1/2"	2"	2 1/2"	3"	4"	5"	6"	8"	10"	12"	14"	16"	18"	20"	24"
NPS	1/2"	3/4"	1"	1 1/4"	1 1/2"	2"	2 1/2"	3"	4"	5"	6"	8"	10"	12"	14"	16"	18"	20"	24"
TOOL	FA1TM		FA41TM																
CLASS 900	TOOL		FA41TM																
NPS	1/2"	3/4"	1"	1 1/4"	1 1/2"	2"	2 1/2"	3"	4"	5"	6"	8"	10"	12"	14"	16"	18"	20"	24"
NPS	1/2"	3/4"	1"	1 1/4"	1 1/2"	2"	2 1/2"	3"	4"	5"	6"	8"	10"	12"	14"	16"	18"	20"	24"
TOOL	FA1TM		FA41TM																
CLASS 1500	TOOL		FA41TM																
NPS	1/2"	3/4"	1"	1 1/4"	1 1/2"	2"	2 1/2"	3"	4"	5"	6"	8"	10"	12"	14"	16"	18"	20"	24"
NPS	1/2"	3/4"	1"	1 1/4"	1 1/2"	2"	2 1/2"	3"	4"	5"	6"	8"	10"	12"	14"	16"	18"	20"	24"
TOOL	FA1TM		FA41TM																
CLASS 2500	TOOL		FA41TM																
NPS	1/2"	3/4"	1"	1 1/4"	1 1/2"	2"	2 1/2"	3"	4"	5"	6"	8"	10"	12"	14"	16"	18"	20"	24"
NPS	1/2"	3/4"	1"	1 1/4"	1 1/2"	2"	2 1/2"	3"	4"	5"	6"	8"	10"	12"	14"	16"	18"	20"	24"
TOOL	FA1TM		FA41TM																

ASME B16.47 FLANGE RANGE OF APPLICATION

CLASS 150	TOOL		FA41TM											
NPS	22"	26"	28"	30"	32"	34"	36"	38"	40"	42"	44"	46"	48"	
NPS	22"	26"	28"	30"	32"	34"	36"	38"	40"	42"	44"	46"	48"	
TOOL	FA41TM		FA97E											
CLASS 300	TOOL		FA41TM											
NPS	22"	26"	28"	30"	32"	34"	36"	38"	40"	42"	44"	46"	48"	
NPS	22"	26"	28"	30"	32"	34"	36"	38"	40"	42"	44"	46"	48"	
TOOL	FA41TM		FA97E											
CLASS 400	TOOL		FA41TM											
NPS	22"	26"	28"	30"	32"	34"	36"	38"	40"	42"	44"	46"	48"	
NPS	22"	26"	28"	30"	32"	34"	36"	38"	40"	42"	44"	46"	48"	
TOOL	FA41TM		FA97E											
CLASS 600	TOOL		FA41TM											
NPS	22"	26"	28"	30"	32"	34"	36"	38"	40"	42"	44"	46"	48"	
NPS	22"	26"	28"	30"	32"	34"	36"	38"	40"	42"	44"	46"	48"	
TOOL	FA41TM		FA97E											
CLASS 900	TOOL		FA41TM											
NPS	22"	26"	28"	30"	32"	34"	36"	38"	40"	42"	44"	46"	48"	
NPS	22"	26"	28"	30"	32"	34"	36"	38"	40"	42"	44"	46"	48"	
TOOL	FA41TM		FA97E											

DIN WELD NECK FLANGE RANGE OF APPLICATION

CLASS PN16	TOOL		FA1TM																									
NPS	1 1/2"	2"	2 1/2"	3"	4"	5"	6"	7"	8"	10"	12"	14"	16"	18"	20"	24"	28"	32"	36"	40"	48"	56"	72"	80"				
NPS	1 1/2"	2"	2 1/2"	3"	4"	5"	6"	7"	8"	10"	12"	14"	16"	18"	20"	24"	28"	32"	36"	40"	48"	56"	72"	80"				
TOOL	FA1TM		FA41TM																									
CLASS PN25	TOOL		FA1TM																									
NPS	1 1/2"	2"	2 1/2"	3"	4"	5"	6"	7"	8"	10"	12"	14"	16"	18"	20"	24"	28"	32"	36"	40"	48"	56"	72"	80"				
NPS	1 1/2"	2"	2 1/2"	3"	4"	5"	6"	7"	8"	10"	12"	14"	16"	18"	20"	24"	28"	32"	36"	40"	48"	56"	72"	80"				
TOOL	FA1TM		FA41TM																									
CLASS PN40	TOOL		FA1TM																									
NPS	1 1/2"	2"	2 1/2"	3"	4"	5"	6"	7"	8"	10"	12"	14"	16"	18"	20"	24"	28"	32"	36"	40"	48"	56"	72"	80"				
NPS	1 1/2"	2"	2 1/2"	3"	4"	5"	6"	7"	8"	10"	12"	14"	16"	18"	20"	24"	28"	32"	36"	40"	48"	56"	72"	80"				
TOOL	FA1TM		FA41TM																									
CLASS PN64	TOOL		FA1TM																									
NPS	3/4"	1"	1 1/2"	2"	2 1/2"	3"	4"	5"	6"	7"	8"	10"	12"	14"	16"	18"	20"	24"	28"	32"	36"	40"	48"	56"	72"	80"		
NPS	3/4"	1"	1 1/2"	2"	2 1/2"	3"	4"	5"	6"	7"	8"	10"	12"	14"	16"	18"	20"	24"	28"	32"	36"	40"	48"	56"	72"	80"		
TOOL	FA1TM		FA41TM																									
CLASS PN100	TOOL		FA1TM																									
NPS	1/2"	3/4"	1"	1 1/2"	2"	2 1/2"	3"	4"	5"	6"	7"	8"	10"	12"	14"	16"	18"	20"	24"	28"	32"	36"	40"	48"	56"	72"	80"	
NPS	1/2"	3/4"	1"	1 1/2"	2"	2 1/2"	3"	4"	5"	6"	7"	8"	10"	12"	14"	16"	18"	20"	24"	28"	32"	36"	40"	48"	56"	72"	80"	
TOOL	FA1TM		FA41TM																									
CLASS PN160	TOOL		FA1TM																									
NPS	3/8"	1/2"	3/4"	1"	1 1/2"	2"	2 1/2"	3"	4"	5"	6"	7"	8"	10"	12"	14"	16"	18"	20"	24"	28"	32"	36"	40"	48"	56"	72"	80"
NPS	3/8"	1/2"	3/4"	1"	1 1/2"	2"	2 1/2"	3"	4"	5"	6"	7"	8"	10"	12"	14"	16"	18"	20"	24"	28"	32"	36"	40"	48"	56"	72"	80"
TOOL	FA1TM		FA41TM																									

	SUITABLE FOR FA1TM TOOL
	SUITABLE FOR FA41TM TOOL
	SUITABLE FOR FA97E TOOL
	NOT SUITABLE FOR TOOLS

6.3 SPO FLANGE RANGE OF APPLICATION

CLASS	TOOL	2 1/2"	3"	3 1/2"	4"	5"	6"	8"	10"	12"	14"	16"	18"	20"	22"	24"	26"	28"	30"	32"	34"	36"	38"	40"	42"	44"	46"	48"
CLASS 150	NPS	2 1/2"	3"	3 1/2"	4"	5"	6"	8"	10"	12"	14"	16"	18"	20"	22"	24"	26"	28"	30"	32"	34"	36"	38"	40"	42"	44"	46"	48"
	TOOL	FA1TM																										
CLASS 300	NPS	2 1/2"	3"	3 1/2"	4"	5"	6"	8"	10"	12"	14"	16"	18"	20"	22"	24"	26"	28"	30"	32"	34"	36"	38"	40"	42"	44"	46"	48"
	TOOL	FA1TM																										
CLASS 600	NPS	2 1/2"	3"	3 1/2"	4"	5"	6"	8"	10"	12"	14"	16"	18"	20"	22"	24"	26"	28"	30"	32"	34"	36"	38"	40"	42"	44"	46"	48"
	TOOL	FA4TM																										
CLASS 900	NPS	2 1/2"	3"	3 1/2"	4"	5"	6"	8"	10"	12"	14"	16"	18"	20"	22"	24"	26"	28"	30"	32"	34"	36"	38"	40"	42"	44"	46"	48"
	TOOL	FA9TE																										
CLASS 1500	NPS	2 1/2"	3"	3 1/2"	4"	5"	6"	8"	10"	12"	14"	16"	18"	20"	22"	24"	26"	28"	30"	32"	34"	36"	38"	40"	42"	44"	46"	48"
	TOOL	FA9TE																										
CLASS 2500	NPS	2 1/2"	3"	3 1/2"	4"	5"	6"	8"	10"	12"	14"	16"	18"	20"	22"	24"												
	TOOL	FA4TM																FA9TE										
CLASS 5000	NPS	2 1/2"	3"	3 1/2"	4"	5"	6"	8"	10"	12"	14"	16"	18"	20"	22"	24"												
	TOOL	FA4TM																FA9TE										
CLASS 7500	NPS	2 1/2"	3"	3 1/2"	4"	5"	6"	8"	10"	12"	14"	16"	18"	20"	22"	24"												
	TOOL	FA4TM																FA9TE										
CLASS 10000	NPS	2 1/2"	3"	3 1/2"	4"	5"	6"	8"	10"	12"	14"	16"	18"	20"	22"	24"												
	TOOL	FA4TM																FA9TE										
CLASS 15000	NPS	2 1/2"	3"	3 1/2"	4"	5"	6"	8"	10"	12"	14"	16"	18"	20"	22"	24"												
	TOOL	FA4TM																FA9TE										

	SUITABLE FOR FA1TM TOOL
	SUITABLE FOR FA4TM TOOL
	SUITABLE FOR FA9TE TOOL
	NOT SUITABLE FOR TOOLS