

SG18TE,SG25TE

SECURE-GRIP IN-LINE HYDRAULIC FLANGE SPREADERS

Operator Instruction Manual



EQUALIZERTM
INTERNATIONAL

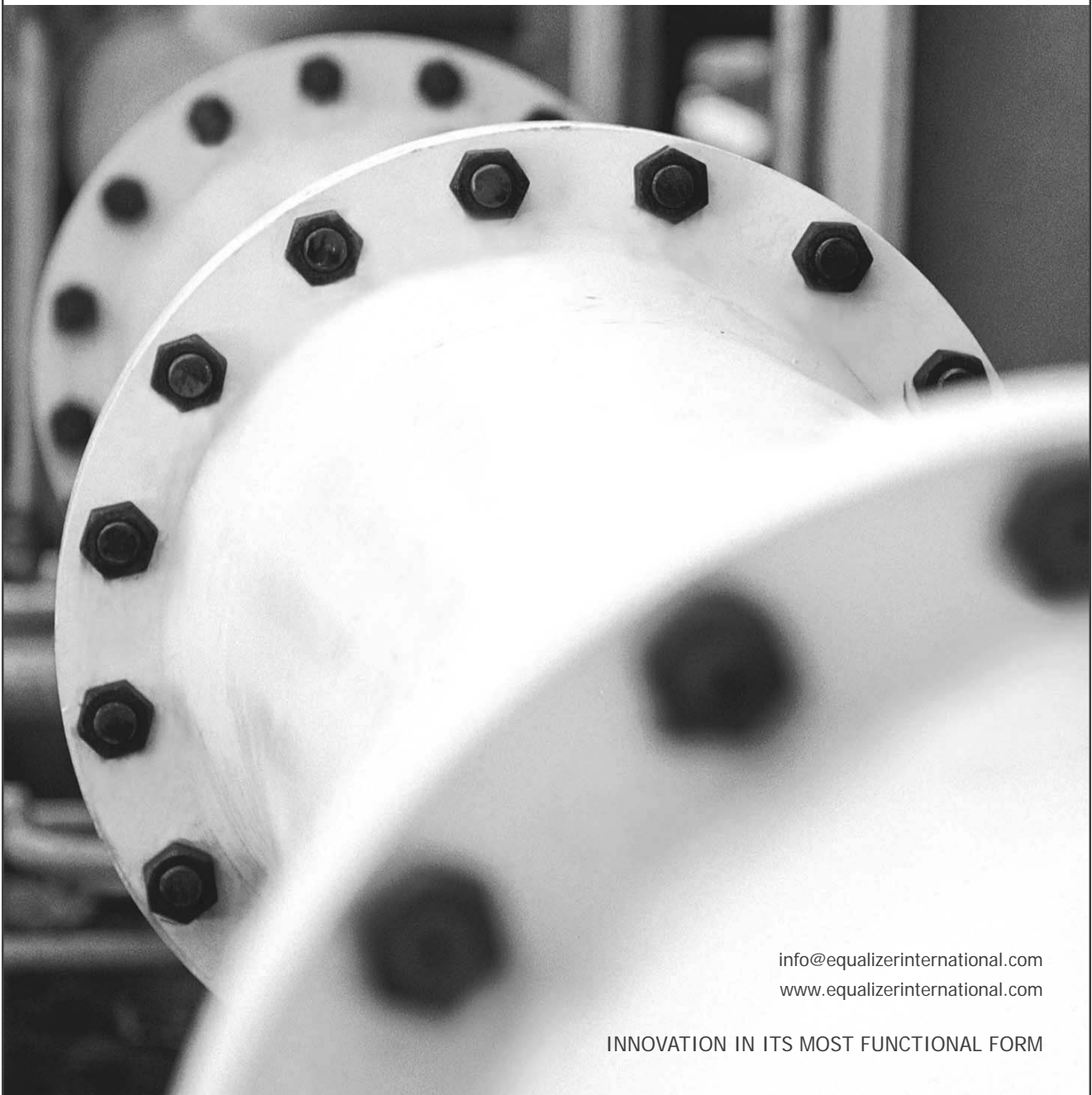

info@equalizerinternational.com
www.equalizerinternational.com

INNOVATION IN ITS MOST FUNCTIONAL FORM



INDEX

SECTION	CONTENTS	PAGE NO.
1	INTRODUCTION	1
2	SAFETY INFORMATION	2-3
3	KIT COMPONENTS	4
4	TECHNICAL DATA	5
5	HOW THE SECURE-GRIP IN-LINE HYDRAULIC TOOLS WORK	6
6	INSTALLATION AND OPERATION	7-18
	6.1 COLLET SELECTION BASED ON FLANGE SPECIFICATION	7
	6.2 COLLET SELECTION BASED ON BOLT-HOLE MEASUREMENT	8-10
	6.3 COLLET REMOVAL AND REPLACEMENT	11-12
	6.4 STANDARD INSTALLATION AND OPERATION	13-16
	6.5 ACCESS GAP INSTALLATION AND OPERATION	17
	6.6 RESTRICTED ACCESS INSTALLATION AND OPERATION	18
7	EXAMINATION, MAINTENANCE AND STORAGE	19-20
8	PARTS LISTS	21-24
9	WEIGHTS AND DIMENSIONS	25
10	TROUBLESHOOTING	26-29
11	SECURE-GRIP TOOL RANGE	30
12	RANGE OF APPLICATION CHARTS	31-40

1. INTRODUCTION

The Equalizer Secure-Grip Flange Spreading Tools are a range of tools designed to assist in the maintenance and installation of pipeline flange assemblies.

The In-Line Hydraulic Secure-Grip Flange Spreading Tools are used to spread flanges with little or no access gap producing a spreading force of up to:

- **36T (360kN)** for the **SG18TE** , **50T (500kN)** for the **SG25TE** when used in pairs.



2. SAFETY INFORMATION

The operator MUST read this manual prior to using the tools.

Failure to comply with the following cautions and warnings could cause equipment damage and personal injury; read the manual fully!

Read all the following instructions, warnings and cautions carefully. Follow all safety precautions to avoid personal injury or property damage during system operation.

Equalizer International Ltd cannot be responsible for damage or injury resulting from unsafe product use, lack of maintenance or incorrect product and/or system operation. Contact Equalizer International Ltd when in doubt as to the safety precautions and applications. To protect your warranty, use only good quality hydraulic oil of the grade 15cSt.

Only people competent in the use of hydraulic equipment should use these tools.

In all installations the site safety requirements must be adhered to. ALSO the safety of the operator, and when present, any assisting personnel, is of paramount importance along with the safety of others including, when present, the general public.

These instructions are only to cover the safe operation of THE EQUALIZER SECURE-GRIP IN-LINE HYDRAULIC TOOLS, during normal maintenance/installation operations. All other safety aspects must be controlled by the operation supervisor.



A **CAUTION** is used to indicate correct operating or maintenance procedures and practices to prevent damage to, or destruction of equipment or other property.

A **WARNING** indicates a potential danger that requires correct procedures or practices to avoid personal injury.

A **DANGER** is only used when your action or lack of action may cause serious injury or even death.



IMPORTANT: Operator must be competent in the use of hydraulic equipment. The operator must have read and understood all instructions, safety issues, cautions and warnings before starting to operate the Equalizer equipment.



WARNING: To avoid personal injury and possible equipment damage, make sure all hydraulic components are rated to a safe working pressure of 700 bar (10,000 psi)



WARNING: Do not overload equipment. Overloading causes equipment failure and possible personal injury.

The risk of overloading can be avoided by using the Equalizer Hand Pump, which has its safety valve set to 700 bar by the factory. If alternative pumps are used, ensure they are rated at a safe working pressure of 700 bar (10,000 psi).



CAUTION: Make sure that all system components are protected from external sources of damage, such as excessive heat, flame, moving machine parts, sharp edges and corrosive chemicals.



CAUTION: Avoid sharp bends and kinks that will cause severe back-up pressure in hoses. Bends and kinks lead to premature hose failure. Do not drop heavy objects onto hoses. A sharp impact may cause internal damage to hose wire strands; applying pressure to a damaged hose may cause it to rupture. Do not place heavy weights on the hoses, or allow vehicles to roll over the hoses; crush damage will lead to premature hose failure.



WARNING: Immediately replace worn or damaged parts with genuine Equalizer parts. Equalizer parts are designed to fit properly and withstand rated loads. For repair or maintenance service contact your Equalizer distributor or service centre.



DANGER: To avoid personal injury keep hands and feet away from the tool and workpiece during operation.



WARNING: Always wear suitable clothing and Personal Protective Equipment (PPE).



DANGER: Do not handle pressurised hoses. Escaping oil under pressure can penetrate the skin, causing serious injury. If oil is injected under the skin, seek medical attention immediately.



WARNING: Never pressurize unconnected couplers. Only use hydraulic equipment in a connected system.



IMPORTANT: Do not lift hydraulic equipment by the hoses or couplers. Use the carrying handle or other means of safe transport.



WARNING: Never place fingers in a joint held by an activated tool



CAUTION: Never hammer or force the tool into a bolt hole; if it does not fit easily you are using the wrong size of tool.



CAUTION: Do not operate the equipment without lubricating all moving parts as in section 7. Use only high pressure molybdenum disulphide grease.



3. KIT COMPONENTS

SG18TE KIT COMPONENTS

- 1 x SG18TE Tool
- 1 x Spreading Plug
- 1 x 10,000 psi (700 bar) HP350S Sealed Hand Pump with Gauge
- 1 x 10,000 psi (700 bar) Hydraulic Hose, 2m (78.75")
- 1 x 300 mm (12") Vernier Calliper
- 1 x 12.5 mm (0.49") Spacer
- 1 x 5 mm Allen Key
- 1 x 50 mm (1.97") Spacer
- 1 x Safety Block
- 2 x M60 Collets
- 2 x M64 (2 1/2") Collets
- 2 x M70 (2 3/4") Collets
- 1 x Instruction Manual
- 1 x Carry-Case with Protective Foam Inserts



Product Code: SG18TESTD

SG25TE KIT COMPONENTS

- 1 x SG25TE Tool
- 1 x Spreading Plug
- 1 x 10,000 psi (700 bar) HP550S Sealed Hand Pump with Gauge
- 1 x 10,000 psi (700 bar) Hydraulic Hose, 2m (78.75")
- 1 x 300 mm (12") Vernier Calliper
- 1 x 12.5 mm (0.49") Spacer
- 1 x Safety Block
- 1 x Instruction Manual
- 1 x Carry-Case with Protective Foam Inserts



Product Code: SG25TESTD

COLLETS (purchased separately)

- | | |
|--------------------------|--------------------------|
| 2 x M76 (3") Collets | 2 x M90 (3 1/2") Collets |
| 2 x M80 (3 1/4") Collets | 2 x M95 (3 3/4") Collets |
| 2 x M84 (3 3/8") Collets | 2 x M100 (4") Collets |



4. TECHNICAL DATA

SG18TE TECHNICAL DATA

Spreading force = 18 tonnes per tool

It is recommended that tools are used in pairs, giving 2 x 18 = 36 tonnes

If using the Equalizer HP350S Hand Pump (or if a hydraulic pressure gauge is fitted), the spreading force per tool can be determined by taking a reading from the gauge. Gauge pressures will produce spreading forces as set out below.

Pressure	Bar	69	207	345	483	690
	psi	1000	3000	5000	7000	10000
Spreading force	T	1.8	5.4	9	12.6	18

Spreading distance = 0 - 100mm (0 - 3.94")

Hydraulic oil grade: 15 centistokes(cSt) @ 40°C tested by ASTM D 445

SG25TE TECHNICAL DATA

Spreading force = 25 tonnes per tool

It is recommended that tools are used in pairs, giving 2 x 25 = 50 tonnes

If using the Equalizer HP550S Hand Pump (or if a hydraulic pressure gauge is fitted), the spreading force per tool can be determined by taking a reading from the gauge. Gauge pressures will produce spreading forces as set out below.

Pressure	Bar	69	207	345	483	690
	psi	1000	3000	5000	7000	10000
Spreading force	T	2.5	7.5	12.5	17.5	25

Spreading distance = 0 - 120mm (0 - 4.72")

Hydraulic oil grade: 15 centistokes(cSt) @ 40°C tested by ASTM D 445



5. HOW THE SECURE-GRIP IN-LINE HYDRAULIC TOOLS WORK

1. The spreading plug is inserted fully into the flange bolt-hole and the drive nut is tightened locking the the spreading plug into the flange



2. The complete tool is then fully inserted into the opposing bolt-hole and the drive nut is tightened locking the tool into the flange

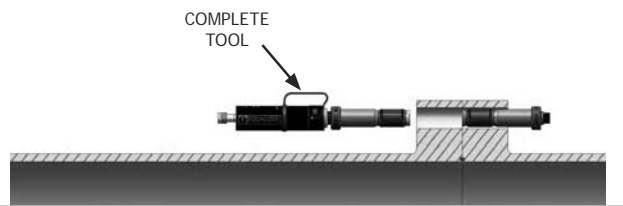

3. The hydraulic hoses and hand pumps are attached

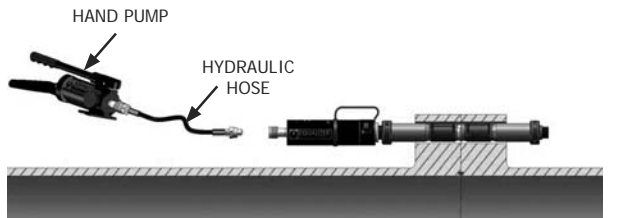

4. The hand pumps are actuated which powers the hydraulics that spread the flange

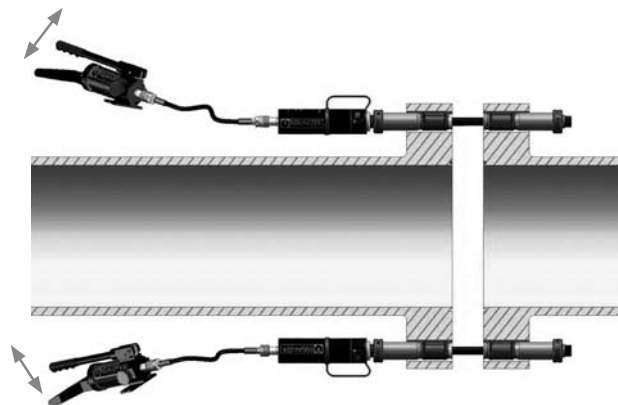



6. INSTALLATION AND OPERATION

6.1 COLLET SELECTION BASED ON FLANGE SPECIFICATION



It is important that the correct size of collet is used!
An undersized collet could allow the collet holder to pull through its bore!
An oversized collet has the potential to become jammed in the bolt-hole!

To select the applicable tool and collet for your flange please refer to the Secure-Grip application charts at the back of this manual (section 12, pages 28-37).

The Secure-Grip in-line hydraulic tools have a range of collets which are applicable to the following bolts and flange bolt-hole diameters:

Collet type	Minimum bolt-hole diameter	Maximum bolt-hole diameter	Metric coarse bolt	UNC bolt	Tool
M60 2 3/8"	59.5mm (2.34")	63mm (2.48")	M60	2 3/8"	SG18TE
M64 2 1/2"	63mm (2.48")	69mm (2.72")	M64	2 1/2"	SG18TE
M70 2 3/4"	69mm (2.72")	75mm (2.95")	M70	2 3/4"	SG18TE
M76 3"	75mm (2.95")	83mm (3.27")	M76	3"	SG25TE
M80 3 1/4"	79mm (3.11")	86mm (3.39")	M80	3 1/4"	SG25TE
M84	83mm (3.27)	89mm (3.5")	M84	Na	SG25TE
M90 3 1/2"	89mm (3.5")	95mm (3.74")	M90	3 1/2"	SG25TE
M95 3 3/4"	94mm (3.7")	101mm (3.98")	M95	3 3/4"	SG25TE
M100 4"	99mm (3.90")	108mm(4.25")	M100	4"	SG25TE

If the specification of the flange is unknown then the vernier calliper supplied in the kit should be used to determine the correct collet as shown in section 6.2, pages 7-9.



Important: The Secure-Grip collets are consumable items. The lifespan of a collet will vary depending on the flange materials with which it is used. To increase the lifespan of the collets it is recommended that they are flipped through 180 degrees on the collet holder each time the tool is used, this will produce more even wear across the four ridges on the outer profile of the collet. See section 6.3 (pages 10-11) for details on collet removal and replacement



6.2 COLLET SELECTION BASED ON BOLT-HOLE MEASUREMENT



Note: It is important that the vernier calliper is held in the middle of the bolt-hole, and not held at an angle to the flange face, nor used on a bolt-hole which is worn, damaged or distorted, as these actions may result in the selection of an incorrect size of collet

1. To ensure a true measurement is taken, hold the vernier calliper:
 - square to the flange face
 - in the middle of the bolt-hole

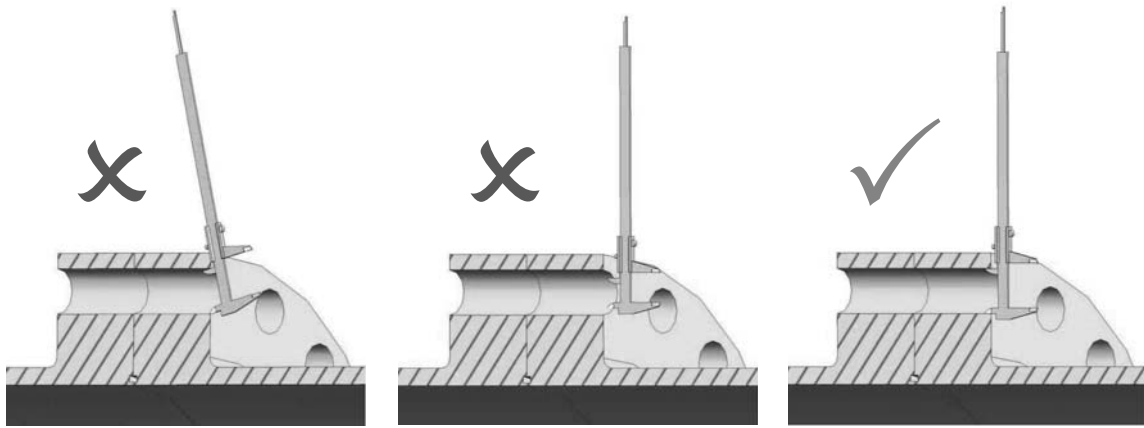

2. To determine whether the bolt-hole is round, take two separate measurements with the vernier calliper turned through 90° between measurements

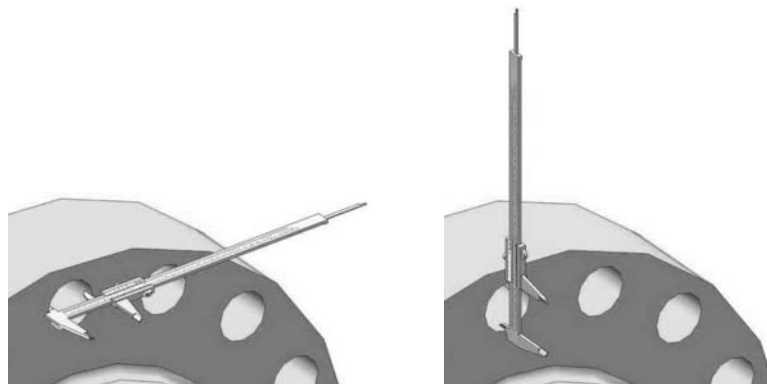



3. To read the measurement from the vernier calliper, scan along the desired scale from left to right. In this example, the major figure is 60mm, this is added to the minor figure of 8mm (indicated by where the vernier scale aligns with the main scale), giving a total measurement of 68mm.

With a bolt-hole size of 68mm, the operator can determine which collet and tool is appropriate to this flange by referring to the Secure-Grip Tool Range chart in section 11, page 27. For example: 68mm falls within the 63mm minimum and 69mm maximum bolt-hole sizes. Therefore collet identification is M64 / 2½" and the tool to be used is the SG18TE.

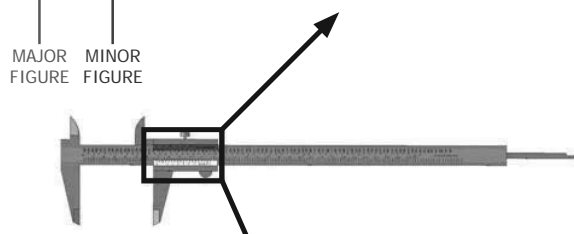
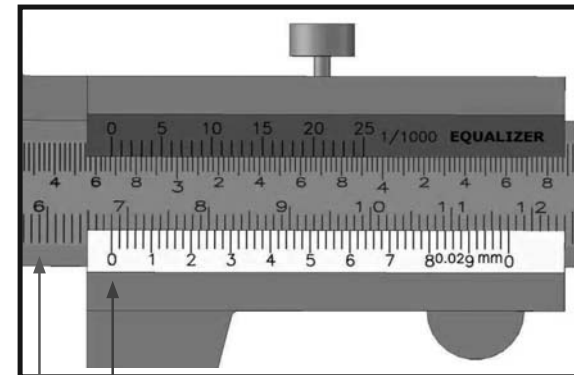

4. If the measurement contains fractions of a millimetre the method of reading the vernier calliper is slightly different. In this example, the major figure is 40mm (read in the same way as previously described). The minor figure is 7mm (read to the left of the zero). The fraction is 0.5mm (read from where the vernier scale lines up with the main scale). This gives a total measurement of 47.5mm.

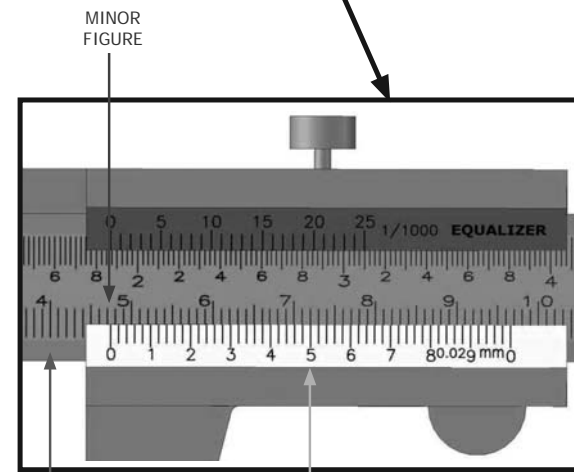



6. Each tool in the Secure-Grip range comes with the appropriate sizes of collets for that tool. If the collet labelling is worn or missing then the collet can be measured to ensure that the correct size is selected. An accurate measurement can only be obtained with the collet mounted on the collet holder. To do this:
- remove the collet head assembly from the tool and disassemble (see section 6.3, page 10-11 for details)
 - slide the collet over the collet holder
 - measure the centre section of the collet with the vernier calliper
 - identify the collet using the chart below, and select the correct size for the flange



Centre section Ø	Collet type	Min. bolt-hole Ø	Max. bolt-hole Ø	Metric coarse bolt	UNC bolt
56mm	M60 2 3/8"	59.5mm (2.34")	63mm (2.48")	M60	2 3/8"
59mm	M64 2 1/2"	63mm (2.48")	69mm (2.72")	M64	2 1/2"
66mm	M70 2 3/4"	69mm (2.72")	75mm (2.95")	M70	2 3/4"
71mm	M76 3"	75mm (2.95")	83mm (3.27")	M76	3"
75mm	M80 3 1/4"	79mm (3.11")	86mm (3.39")	M80	3 1/4"
80mm	M84	83mm (3.27)	89mm (3.5")	M84	NA
84mm	M90 3 1/2"	89mm (3.5")	95mm (3.74")	M90	3 1/2"
90mm	M95 3 3/4"	94mm (3.7")	101mm (3.98")	M95	3 3/4"
95mm	M100 4"	99mm (3.90")	108mm(4.25")	M100	4"



6.3 COLLET REMOVAL AND REPLACEMENT

Once the correct collet has been selected it may be necessary to change the collet on the tool and the collet on the spreading plug:

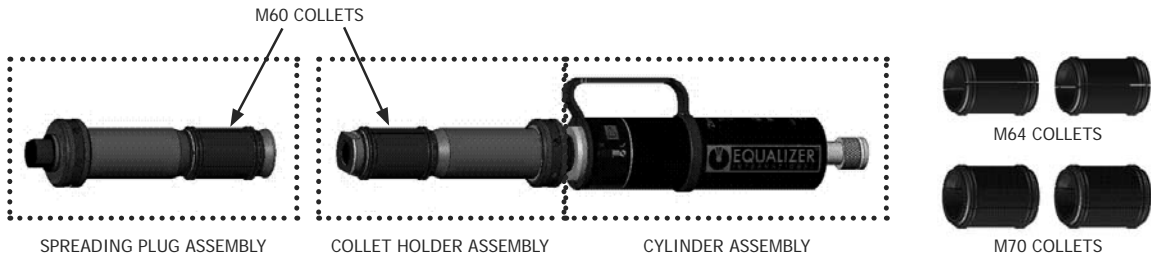

TOOL COLLET

1. Unscrew the collet holder assembly from the cylinder assembly

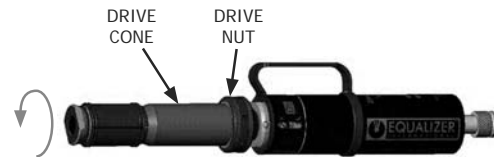

2. Slide the collet holder assembly off the piston rod

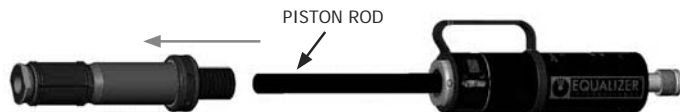

3. Unscrew the drive nut



4. Slide the drive cone off



5. Slide the collet off



6. Select the correct size of collet for the flange being worked on and reassemble by reversing steps 1-5



CAUTION: It is essential that the collet holder is screwed fully into the cylinder assembly with the indicator dowel next to the green tick. The safety of the tool will be compromised if it is not, and damage to the tool and injury to the operator may result.

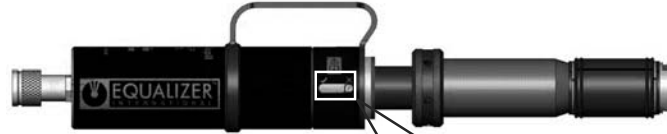

Incorrect:
Do not use with the indicator dowel in this position. The collet holder must be screwed right in until the indicator dowel is beside the green tick.



Correct:
The indicator dowel is now beside the green tick. The tool is now ready to use.

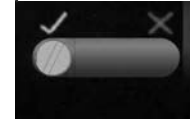

The spring-loaded indicator dowel shows how far the collet holder has been screwed into the cylinder assembly. If the collet holder is not screwed right in before use, failure of either the collet holder or the cylinder assembly may result, potentially injuring the operator and damaging the flange being spread.

SPREADING PLUG COLLET

1. Unscrew the drive nut



2. Slide the drive cone off



3. Slide the collet off



4. Select the correct size of collet for the flange being worked on and reassemble by reversing steps 1-3



6.4 STANDARD INSTALLATION AND OPERATION

Once the correct collet has been selected and attached to the tool, operations can commence



Before attaching the tool ensure at least two flange bolts remain in place 180 degrees apart with nuts loosened sufficiently enough for flange work to be carried out. These bolts will reduce lateral flange movement during flange spreading.

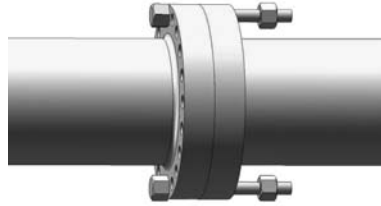

1. Measure the thickness of the flange using the vernier calliper provided. Lock the calliper in position by tightening the locking screw

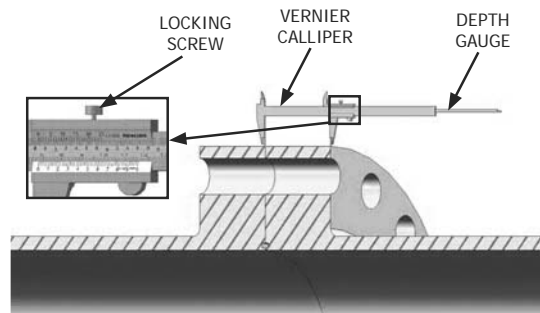

2. Select one of the the bolt-holes adjacent to the remaining bolts.

Insert the depth gauge part of the vernier calliper into the bolt-hole keeping the base of the calliper flush with the bolting face of the flange

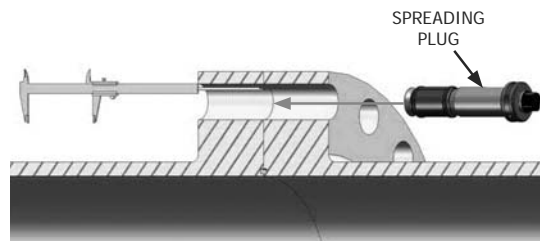

Insert the spreading plug into the opposite end of the same bolt-hole until it touches the end of the depth gauge (so that the collet is fully through one flange but not entering the other)

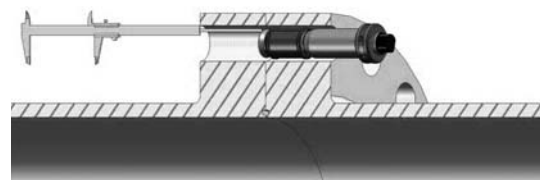

3. Tighten the drive nut with the 'C' spanner. The collet will now have a secure grip in the bolt-hole.

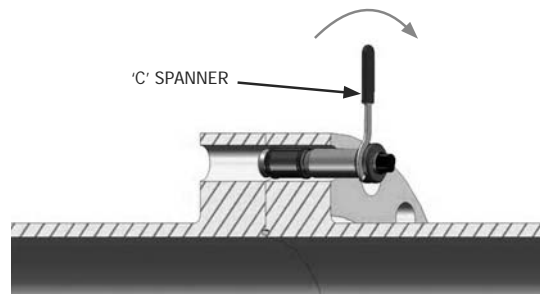



4. Fit the complete tool into the other side of the bolt-hole until it touches the spreading plug

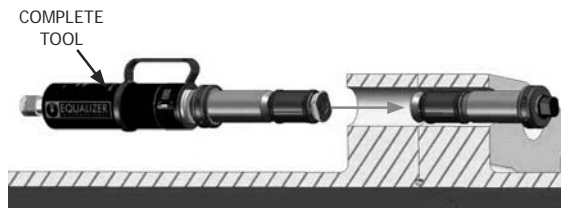

5. Tighten the drive nut to lock the collet in the bolt-hole

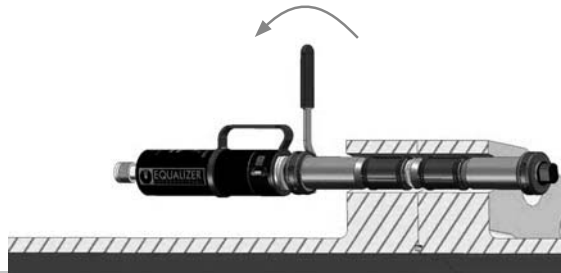

6. Fit the second tool 180° opposite to the first tool using the same method

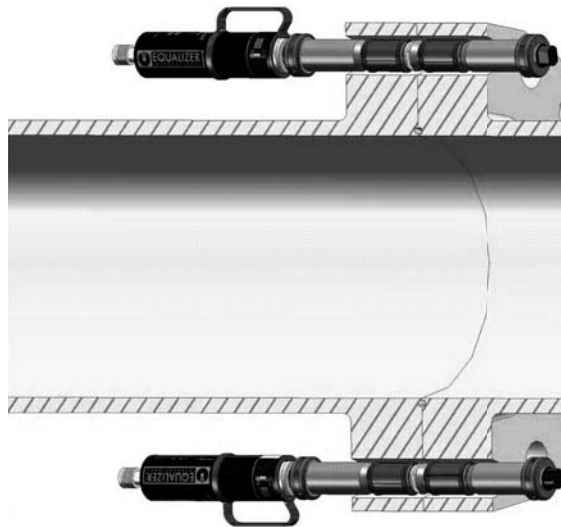



7. Connect the hand pumps using the hydraulic hoses supplied, ensuring that all couplers are fully hand tightened and both release valves are closed hand tight.

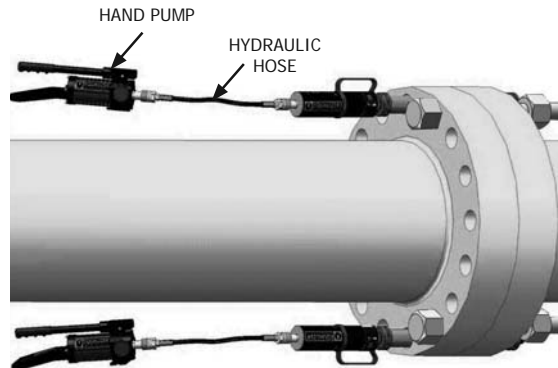

8. Flange spreading can now begin. Prime the hand pumps, increasing the pressure on each tool gradually (using the gauge on each hand pump as a guide).

The spreading force available from the SG18TE is 18 T (36 T when used in pairs), and the maximum spreading distance is 100 mm (3.94")

The spreading force available from the SG25TE is 25 T (50 T when used in pairs), and the maximum spreading distance is 120 mm (4.72")

provided the tools start with the flanges in the fully closed position.

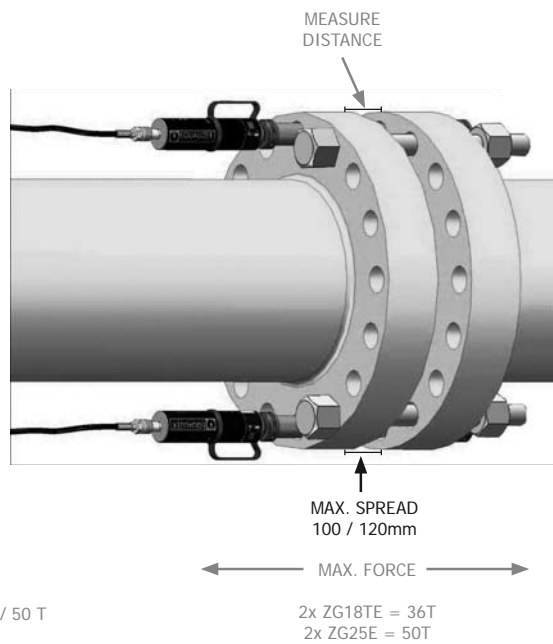

9. Once the flange has been spread and prior to any maintenance works the safety blocks must be inserted between the flanges. These are held in position by replacing two of the flange bolts.

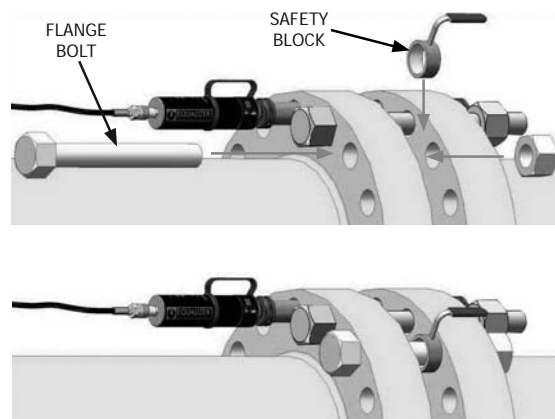



10. Following any maintenance works and prior to closing the flange joint, the safety block must be removed. The release valves on the hand pumps should now be turned anti-clockwise gently and evenly, adjusting as necessary to keep the flanges parallel until the flange is fully closed and there is no load on the tools. The tools can then be removed by reversing the installation procedure (steps 2-7)

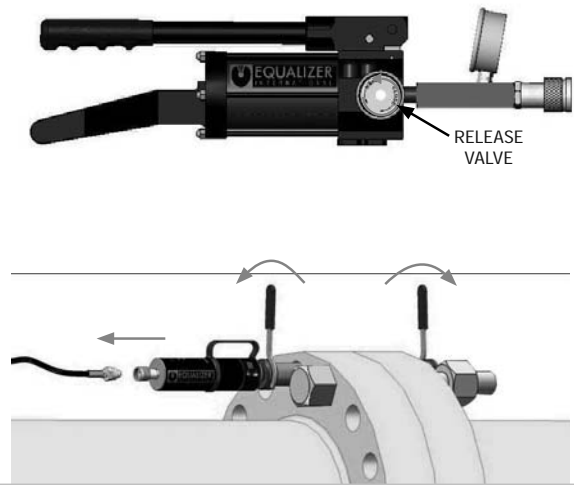



6.5 ACCESS GAP INSTALLATION AND OPERATION

The Secure-Grip tools are also ideal for use on flanges with an access gap. Using the spreading plugs is unnecessary as spacers can be used instead. The spacer assemblies can be adjusted from 12.5 mm to 50 mm thick (SG18TE only) using the 50 mm adapter and fixing screw. Use the largest size that will easily fit in the access gap.

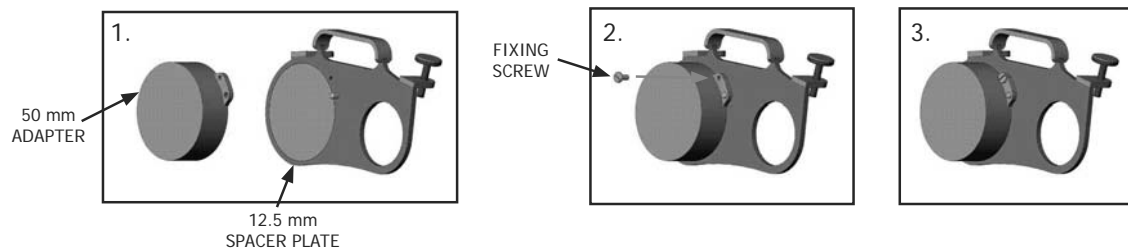
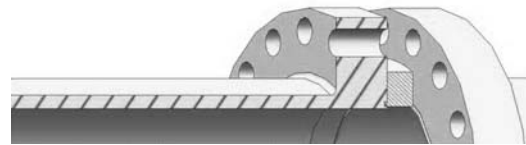

1. Insert the spacer into the access gap and hold it in position using one of the flange bolts

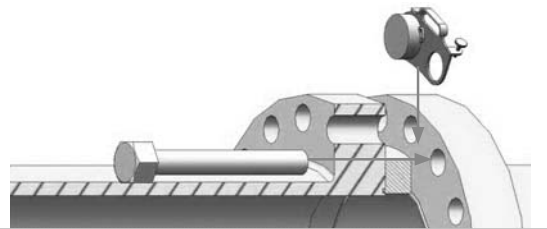

2. Turn the thumbscrew clockwise to lock the spacer against the flange

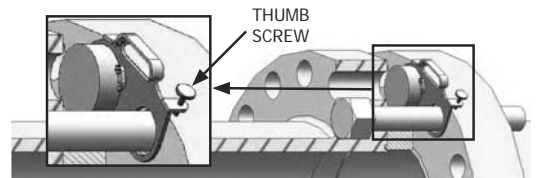

3. Insert the complete tool into the bolt-holes as shown



4. Tighten the drive nuts with the 'C' spanner

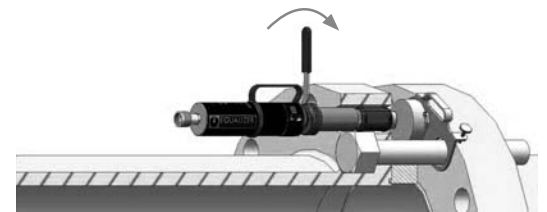

The procedure can now be completed by following steps 7 - 10 of the standard installation procedure (see section 6.4, pages 12-15)



6.6 RESTRICTED ACCESS INSTALLATION AND OPERATION

The Secure-Grip in-line hydraulic tools are also ideal for use where access to the flange is restricted. As in the standard operation, two tools should be used in order to avoid flange distortion, with the tools positioned 180° from each other on the flange.

1. Measure the thickness of the flange with the vernier calliper provided

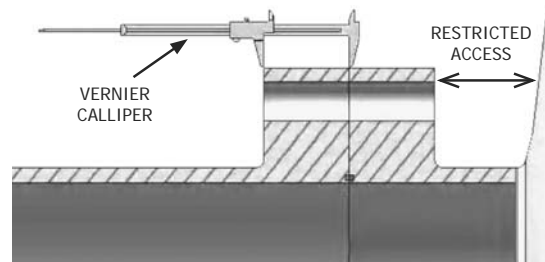

2. Remove the drive nut from the spreading plug and position it between the flange and the restriction as shown. With the nut removed ensure the drive cone does not fall or slide off the spreading plug during installation.

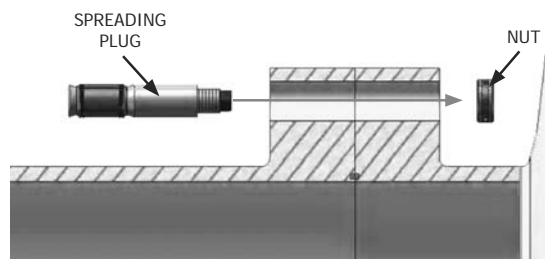

3. Pass the spreading plug collet and drive cone through the bolt-hole and refit the drive nut. Using the vernier calliper as a depth gauge, adjust the position of the spreading plug in the bolt-hole so that the collet is fully through one flange but not entering the bolt-hole of the other.

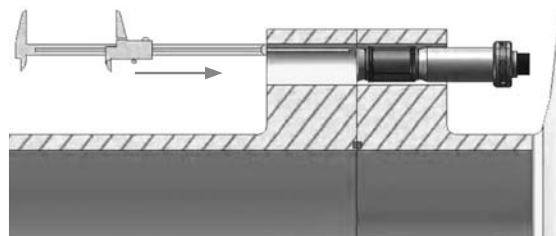

4. Tighten the drive nut with the 'C' spanner

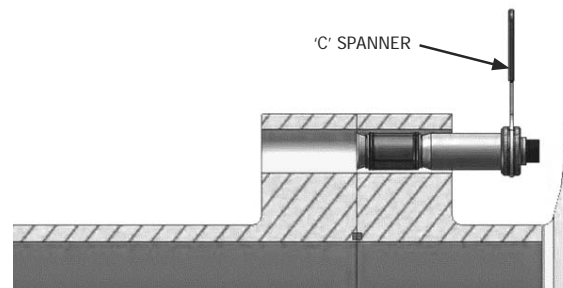

The procedure can now be completed by following steps 4 - 10 of the standard installation procedure (see section 6.4)



7. EXAMINATION, MAINTENANCE AND STORAGE

On return from each job and before allocation against subsequent work the completeness of the Equalizer Secure-Grip hydraulic tool kits must be established and items examined to ensure that they are serviceable. The Secure-Grip tools should be stored in a cool dry place.

At regular intervals and specifically after exposure to salt water Secure-Grip in-line hydraulic tools should be dismantled, all moving parts cleaned with a clean rag and WD40 (or similar) to remove dirt and old grease, and then relubricated:

1. Unscrew the collet holder assembly from the cylinder assembly

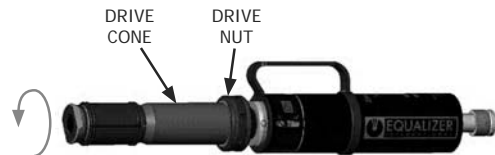

2. Slide the collet holder assembly off the piston rod

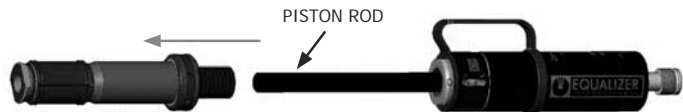

3. Unscrew the drive nut



4. Slide the drive cone and collet off



5. Unscrew the drive nut from the spreading plug



6. Slide the drive cone and collet off



7. Remove the nylon washers from both drive nuts

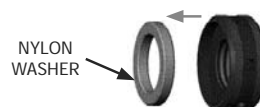



8. Unscrew the piston rod from the cylinder assembly



9. Unscrew the indicator dowels to release the spring collar and safety spring

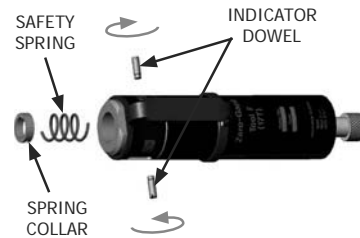

10. Clean all components with a rag and WD40 (or similar), removing any visible dirt or grit (paying particular attention to the collets, collet holder and collet plug).

Smear all mating surfaces with a high performance molybdenum disulphide grease such as Rocol Sapphire Hi-Load 2.

Inspect all components for wear and damage. Replace all worn and damaged components with genuine Equalizer spares.

11. Reassemble by reversing steps 1-9



CAUTION: It is essential that the piston rod is screwed fully into the cylinder assembly. Failure to do this will result in damage to the threaded section and possible tool failure.



8. PARTS LISTS

SG18TE SPREADING PLUG PARTS LIST

ITEM	PART No.	DESCRIPTION	QUANTITY
01	666001-01	COLLET PLUG	01
02	663101-02	M60 SPRING RING	02
	633501-02	M64 SPRING RING	02
	633701-02	M70 SPRING RING	02
03	663001-01	M60 COLLET	01
	663401-01	M64 COLLET	01
	633601-01	M70 COLLET	01
04	662201-01	DRIVE CONE	01
05	662101-01	NYLON WASHER	01
06	662001-01	DRIVE NUT	01
07	662601-01	SPANNER	01
08	312301-02	SPANNER SLEEVE	01

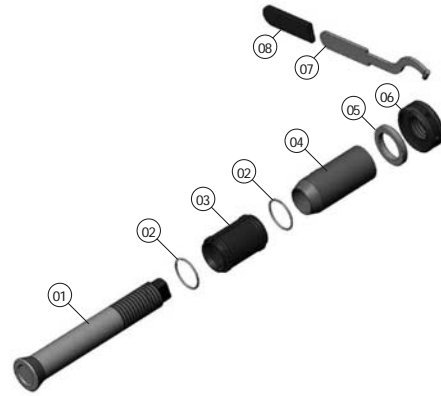

SG18TE ACTUATOR PARTS LIST

ITEM	PART No.	DESCRIPTION	QUANTITY
01	662301-01	COLLET HOLDER	01
02	662401-01	PISTON ROD	01
03	663101-02	M60 SPRING RING	02
	633501-02	M64 SPRING RING	02
	633701-02	M70 SPRING RING	02
04	663001-01	M60 COLLET	01
	663401-01	M64 COLLET	01
	633601-01	M70 COLLET	01
05	662201-01	DRIVE CONE	01
06	662101-01	NYLON WASHER	01
07	662001-01	DRIVE NUT	01
08	661401-01	SPRING COLLAR	01
09	661301-01	SAFETY SPRING	01
10	661101-01	DOWEL PIN	02
11		SEE HYDRAULIC CYLINDER PARTS LIST	01

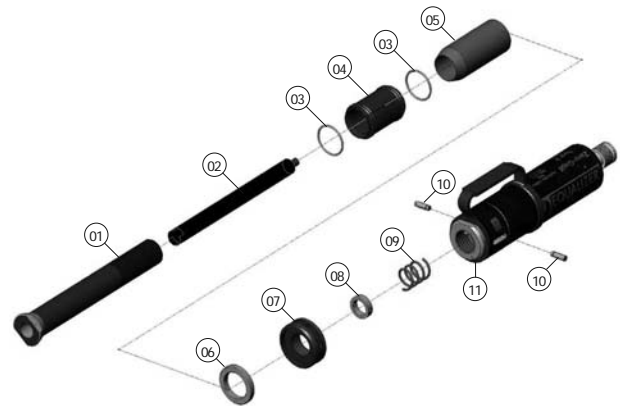

SG18TE HYDRAULIC CYLINDER PARTS LIST

ITEM	PART No.	DESCRIPTION	QUANTITY
01	660801-01	PISTON	01
02	660501-01	PISTON SEAL	01
03	660301-01	PISTON BACKUP RING	01
04	660701-01	PISTON PACKING	01
05	660401-01	CYLINDER BODY	01
06	661601-01	INNER RETURN SPRING	01
07	660901-01	OUTER RETURN SPRING	01
08	661201-01	CYLINDER CAP	01
09	661501-01	CYLINDER HANDLE	01
10	402101-01	M5 CAPHEAD SCREW	02

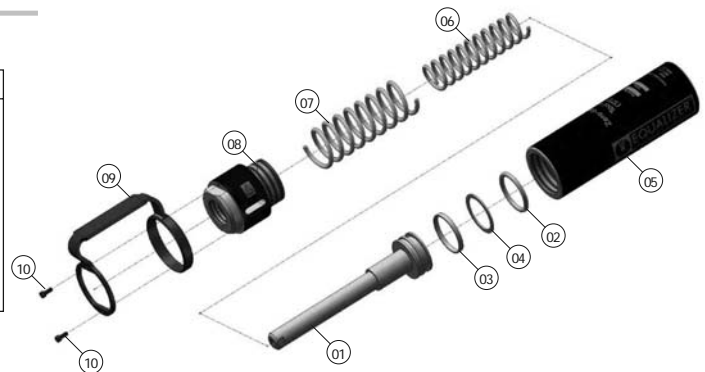



SG25TE SPREADING PLUG PARTS LIST

ITEM	PART No.	DESCRIPTION	QUANTITY
01	676001-01	COLLET PLUG	01
02	672201-02	DRIVE CONE	01
03	672101-04	THRUST WASHER	02
04	675501-02	DRIVE TUBE	01
05	672001-02	DRIVE NUT	01
06	662601-01	SPANNER	01
07	312301-02	SPANNER SLEEVE	01

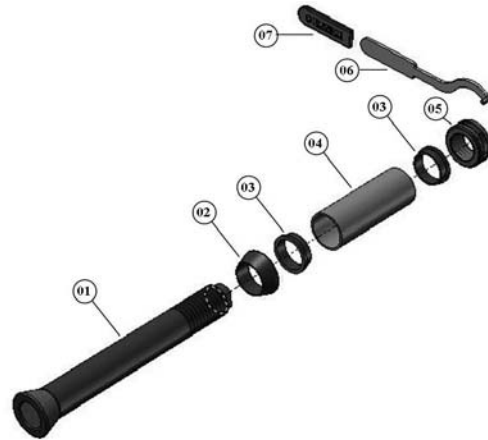

SG25TE ACTUATOR PARTS LIST

ITEM	PART No.	DESCRIPTION	QUANTITY
01	672301-01	COLLET HOLDER	01
02	672201-02	DRIVE CONE	01
03	672101-04	THRUST WASHER	02
04	675501-02	DRIVE TUBE	01
05	672001-02	DRIVE NUT	01
06	672401-01	PISTON ROD	01
07	671401-01	SPRING COLLAR	01
08	661301-01	SAFETY SPRING	01
09	661101-02	SPRING COLLAR DOWELL	02
10		SEE HYDRAULIC CYLINDER PART LIST	

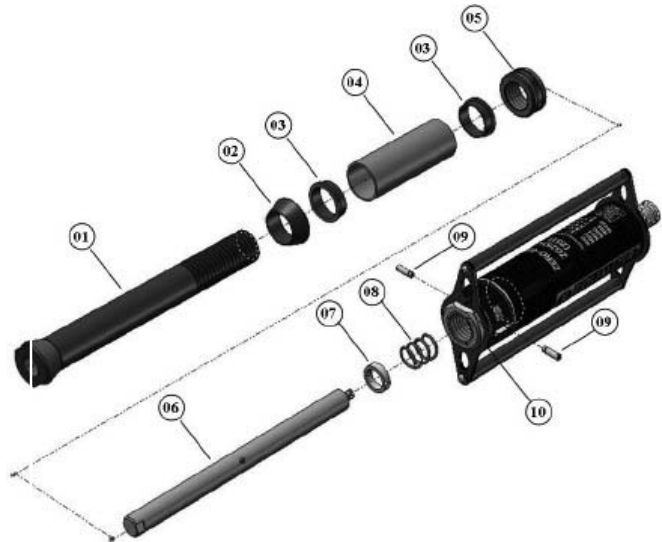

SG25TE HYDRAULIC CYLINDER PARTS LIST

ITEM	PART No.	DESCRIPTION	QUANTITY
01	402101-01	HANDLE SCREWS	02
02	633001-01	HANDLE RETAINING BOLT	04
03	671501-01	CYLINDER HANDLE FRONT PROFILE	01
04	671201-01	CYLINDER CAP	01
05	671001-01	PISTON ROD BEARING	01
06	671101-01	HYDRAULIC RETURN SPRING 1	01
07	670901-01	HYDRAULIC RETURN SPRING 2	01
08	671701-01	CYLINDER HANDLE	01
09	671601-01	CYLINDER HANDLE REAR PROFILE	01
10	670801-01	HYDRAULIC PISTON	01
11	670601-01	PISTON SEAL BACKUP RING	01
12	670501-01	PISTON SEAL	01
13	670701-01	PISTON BEARING	01
14	670401-01	HYDRAULIC CYLINDER	01
15	300901-01	FEMALE HALF COUPLER	01

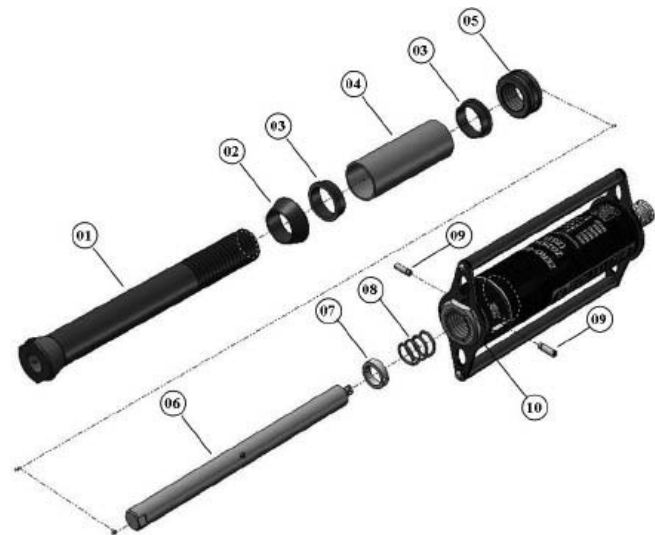



HP350S HAND PUMP

ITEM	PART No.	DESCRIPTION	KIT QUANTITY	PUMP QUANTITY
01	710101-01	PUMP HOUSING		01
02	715100-01	SERVICE KIT A:		
03		- OIL FILTER	01	01
04		- O-RING	01	01
05		- RESERVOIR BLADDER	01	01
06		- REFILLING PLUG	01	01
07	710601-01	RESERVOIR		
08	725200-01	SERVICE KIT B:		
09		- TAIL BASE	01	01
10		- SCREW	04	04
11		- SPRING WASHER	04	04
12		- NUT	04	04
13	715300-01	SERVICE KIT C:		
14		- O-RING	01	01
15		- BACK-UP RING	01	01
16		- PUMP PISTON	01	01
17		- SNAP RING	01	01
18		- O-RING	01	01
19		- BACK-UP RING	01	01
20		- PUMP PISTON	01	01
21		- SNAP RING	01	01
22		- O-RING	01	01
23		- BACK-UP RING	01	01
24		- PUMP PISTON	01	01
25	715400-01	SERVICE KIT D:		
26		- HANDLE	01	01
27		- YOKE	01	01
28		- PISTON PIN	01	01
29		- YOKE PIN	01	01
30		- RETAINING RING	01	01
31		- HANDLE GRIP	01	01
32		- SCREW	01	01
33	715500-01	SERVICE KIT E:		
34		- YOKE BASE	01	01
35		- SPRING PIN	01	01
36	715600-01	SERVICE KIT F:		
37		- RELEASE VALVE	01	01
38		- SCREW	01	01
39		- WASHER	01	01
40		- SEAL	01	01
41		- SCREW	01	01
42		- RELEASE KNOB	01	01
43		- COUPLERS	01	01
44		- CHECK BALL	01	01
45	715700-01	SERVICE KIT G:		
46		- SPRING	02	02
47		- STEEL BALL	02	02
48		- OUTLET BALL SPRING	02	02
49		- COPPER WASHER	02	02
50		- VALVE COVER SCREW	02	02
51		- STEEL BALL	02	02

ITEM	PART No.	DESCRIPTION	KIT QUANTITY	PUMP QUANTITY
40	715800-01	SERVICE KIT H:		
41		- STEEL BALL	01	01
42		- SPRING END CAP	01	01
43		- L.P. SPRING	01	01
44		- O-RING	02	02
45		- OVERLOAD COVER	01	01
46		- SCREW	02	02
47		- CAP	01	01
48		- OVERLOAD COVER	01	01
49		- SCREW	1	01
50		- CONE SEATO	01	01
51		- CONE	01	01
52		- LONG SEPARATOR	01	01
53	715900-01	SERVICE KIT I:		
54		- BASE PLATE	01	01
55		- SCREW	02	02
56	716100-01	SERVICE KIT K:		
57		- SCREW	04	03
58		- SCREW	01	01
59		- SCREW	01	01
60		- SCREW	01	01
61		- CHECK BALL	04	03
62	716200-01	SERVICE KIT L:		
63		- GAUGE COUPLER	01	01
64		- MALE		
65		- GAUGE	01	01
66	716300-01	SERVICE KIT M:		
67		- GAUGE COUPLER	01	01
68		- FEMALE		
69		- COUPLER	01	01
70		- GAUGE PORT	01	01
71		- ADAPTOR		

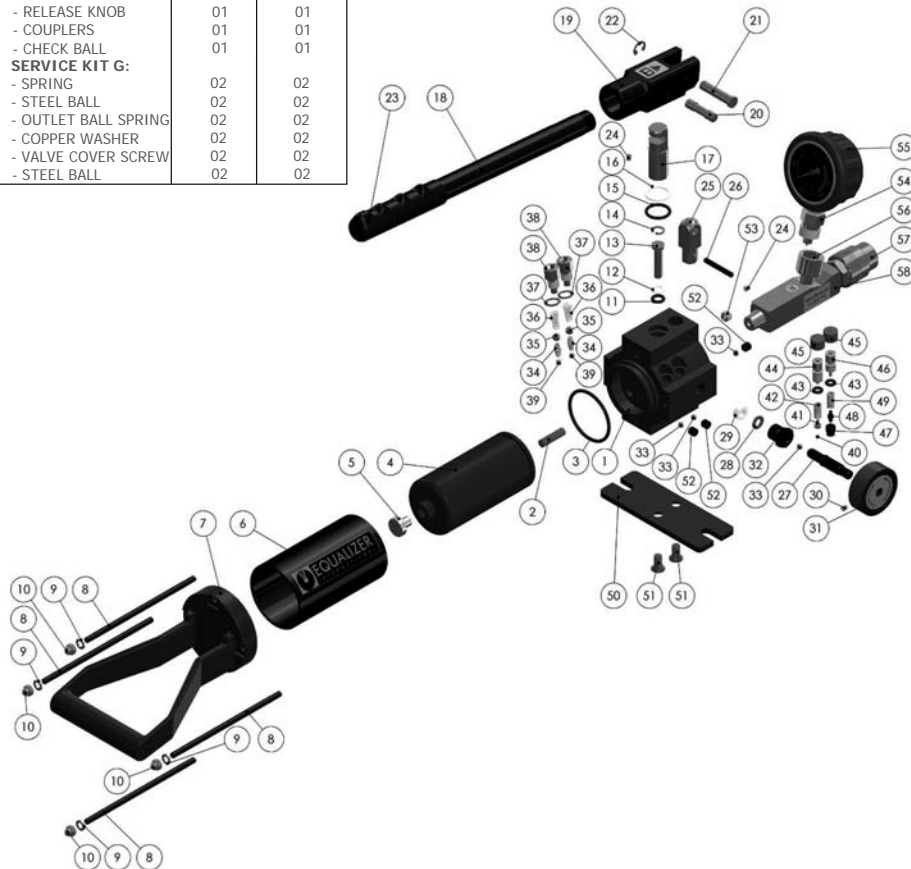



HP550S HAND PUMP

ITEM	PART No.	DESCRIPTION	KIT QUANTITY	PUMP QUANTITY
01	710101-01	PUMP HOUSING		01
02	730601-01	RESERVOIR		01
	715300-01	SERVICE KIT C:		
03		- O-RING	01	01
04		- BACK-UP RING	01	01
05		- H.P. PISTON	01	01
06		- SNAP RING	01	01
07		- O-RING	01	01
08		- BACK-UP RING	01	01
09		- L.P. PISTON	01	01
	715500-01	SERVICE KIT E:		
10		- YOKE BASE	01	01
11		- SPRING PIN	01	01
	715600-01	SERVICE KIT F:		
12		- SEAL	01	01
13		- WASHER	01	01
14		- RELEASE VALVE SCREW	01	01
15		- SCREW	01	01
16		- RELEASE KNOB	01	01
17		- COUPLERS	01	01
37		- CHECK BALL	01	01
	715700-01	SERVICE KIT G:		
18		- SPRING	02	02
19		- STEEL BALL	02	02
20		- OUTLET BALL SPRING	02	02
21		- COPPER WASHER	02	02
22		- VALVE COVER SCREW	02	02
23		- STEEL BALL	02	02
	715800-01	SERVICE KIT H:		
24		- STEEL BALL	01	01
25		- SPRING END CAP	01	01
26		- L.P. SPRING	01	01
27		- O-RING	02	02
28		- OVERLOAD COVER SCREW	01	01
29		- CAP	02	02
30		- CONE SEAT	01	01
31		- CONE	01	01
32		- LONG SEPARATOR SPRING	01	01
33		- OVERLOAD COVER SCREW	01	01
	715900-01	SERVICE KIT I:		
34		- BASE PLATE	01	01
35		- SCREW	02	02
	716100-01	SERVICE KIT K:		
36		- SCREW	04	03
37		- CHECK BALL	04	03
38		- SCREW	01	01
54		- SCREW	01	01
	716200-01	SERVICE KIT L:		
39		- GAUGE COUPLER MALE	01	01
40		- GAUGE	01	01

ITEM	PART No.	DESCRIPTION	KIT QUANTITY	PUMP QUANTITY
	716300-01	SERVICE KIT M:		
41		- GAUGE COUPLER FEMALE	01	01
42		- COUPLER	01	01
43		- PORT GAUGE ADAPTOR	01	01
	735100-01	SERVICE KIT N:		
44		- RESERVOIR BLADDER	01	01
45		- OIL FILTER	01	01
46		- O-RING	01	01
47		- REFILLING PLUG	01	01
	735300-01	SERVICE KIT O:		
48		- HANDLE	01	01
49		- YOKE	01	01
50		- PISTON PIN	01	01
51		- YOKE PIN	01	01
52		- RETAINING RING	01	01
53		- HANDLE GRIP	01	01
54		- SCREW	01	01
	735200-01	SERVICE KIT P:		
55		- SCREW	04	04
56		- TAIL BASE	01	01
57		- SPRING WASHER	04	04
58		- NUT	04	04

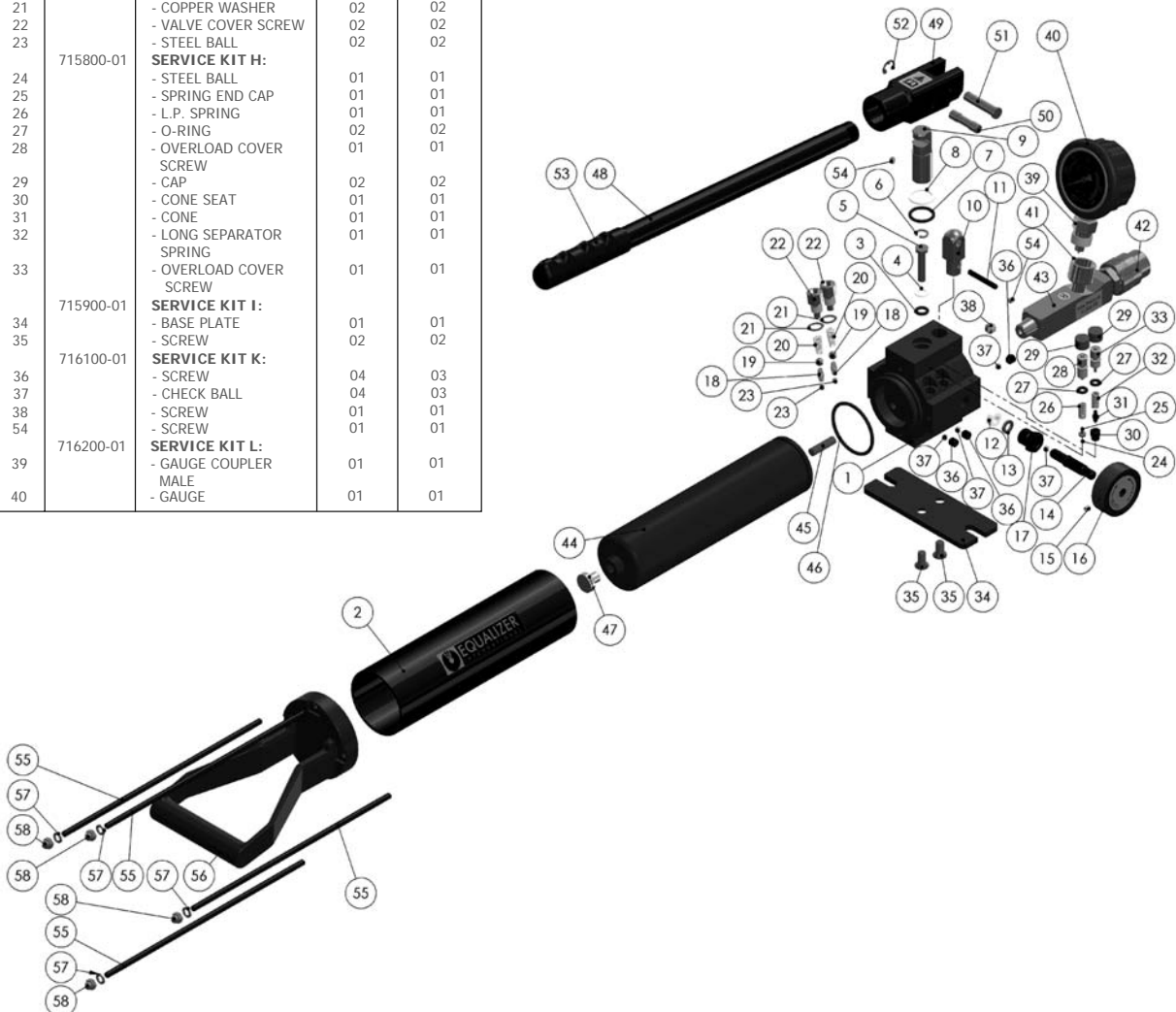



9. WEIGHTS AND DIMENSIONS

SG18TE WEIGHTS AND DIMENSIONS

CLOSED DIMENSIONS

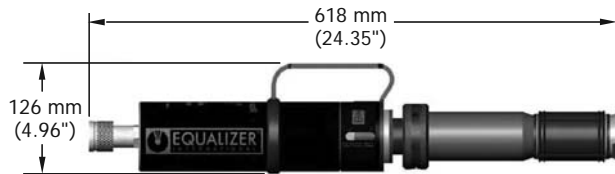

OPEN DIMENSIONS



SPREADING PLUG DIMENSIONS

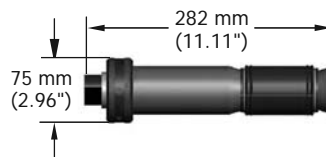

Tool Weight = 14 kg (30.8 lbs)
GROSS KIT WEIGHT = 45 kg (99 lbs)

SG25TE WEIGHTS AND DIMENSIONS

CLOSED DIMENSIONS

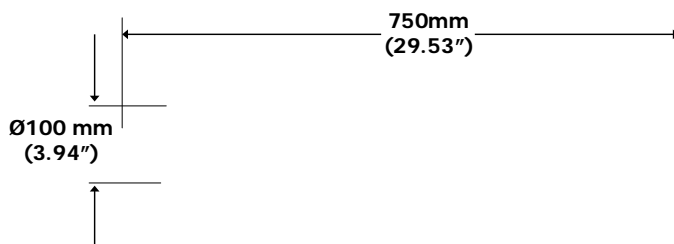

OPEN DIMENSIONS

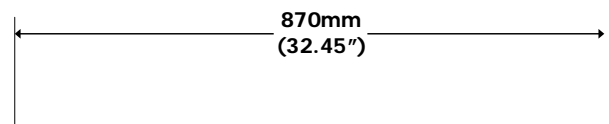

SPREADING PLUG DIMENSIONS

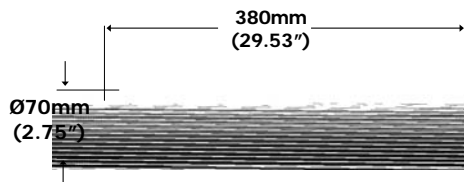

Tool Weight = 21 kg (46.2 lbs)
GROSS KIT WEIGHT = 48 kg (105.6 lbs)



10. TROUBLESHOOTING

Problem: Hoses are connected but the tool does not advance. The pressure on the pump handle is minimal.

- The release valve is in the retract (open) position
- Close the release valve



Problem: Hoses are connected and the pump quickly reaches maximum pressure but the tool has not advanced

- One or more of the connectors are not fully tightened and the hydraulic oil cannot pass through from the pump to the cylinder
- Check all connectors are fully tightened and the release valve is in the fully closed position

Problem: Hoses are connected and the tool advances with maximum pressure on the pump handle but the joint will not spread

- The pressure required to spread the joint is greater than that of the two tools you are using
- Add another one or two tools and distribute them equally around the joint (120° apart with 3 tools and 90° apart with 4 tools) and try again

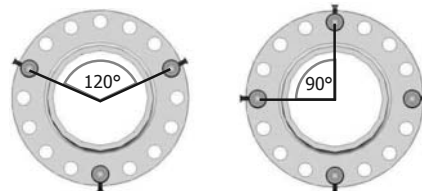

Problem: Hoses are connected and the tool advances but there is minimal pressure on the pump handle and the handle is rising back of its own accord

- There is dirt or a damaged valve seat within the pump unit
- The pump should be sent to an authorised Equalizer distributor for repair



Problem: Hoses are connected and the tool advances as the pump is primed but the pressure on the pump handle is minimal and feels spongy

→ Air could be present in the hydraulic system

→ Use the airlock removal procedure as follows:

1. Connect the hand pump to the tool with the hydraulic hose
2. Close the release valve on the pump, and prime the pump until the hydraulic cylinder is fully extended and a small pressure is achieved
3. With the hand pump held above the tool and the tool in an upright position, open the release valve causing any air that is within the system to be forced up through the pump and vented into the oil reservoir
4. Repeat steps 1 - 3 three or four times to ensure that all air is removed from the system and the tool will reach full working pressure
5. Disconnect the hand pump from the hydraulic hose, grip the baseplate of the hand pump body in a vice with the pump body vertical and the main handle at the top
6. Remove the four nuts holding the main handle and lift off
7. Grip the refilling plug with pliers and extract it by pulling and twisting simultaneously. Ensure the reservoir body is held down when removing the refilling plug as pulling up on the reservoir body will release the bladder within, and oil will spill out.
8. Fill the reservoir to the top with a good quality hydraulic oil of the grade 15 cSt
9. Reinsert the refilling plug, wipe away any oil, and reassemble by reversing the disassembly process





Problem: One collet is jammed in a bolt-hole

→ A collet which is too small or large has been selected, or the collet has been inserted into a damaged or non-round bolt-hole

→ Removal can be achieved as follows:

If the jammed collet is on the collet holder:

1. Release all hydraulic pressure from the tool by turning the release valve anti-clockwise
2. Remove the hydraulic hose from the cylinder assembly
3. Unscrew the cylinder assembly from the collet holder
4. Unscrew the drive nut and remove the drive cone
5. Screw the drive nut back onto the collet holder until it is 1-2 mm off the end
6. Using a hammer and a suitable drift move the collet holder until the drive nut is against the flange
7. Remove the drive nut and push the collet holder through the flange and out of the other end of the bolt-hole
8. Drive the collet out using the spreading plug

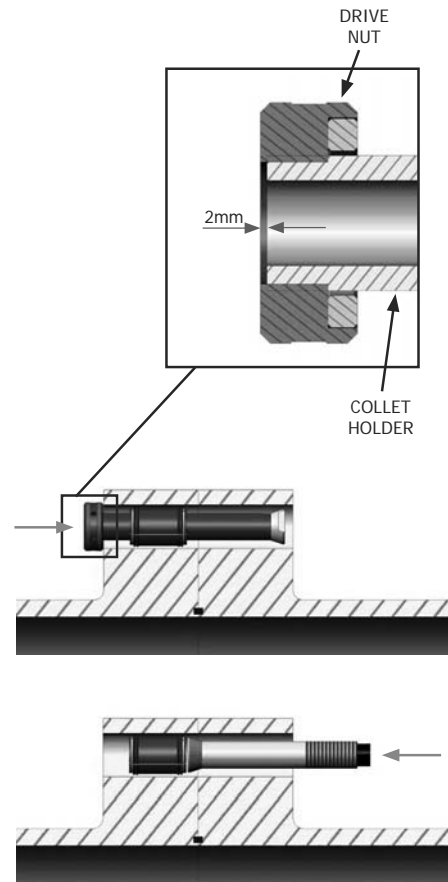

If the jammed collet is on the collet spreading plug:

1. Unscrew the drive nut and remove the drive cone
2. Using a hammer and a suitable drift, drive the spreading plug out of the other end of the bolt-hole
3. Drive the collet out using the spreading plug



Problem: A pair of collets, complete with the spreading plug and collet holder, are jammed in a bolt hole

→ A collet which is too small or large has been selected, or the collet has been inserted into a damaged or non-round bolt hole

→ The flange must be spread before removal can be attempted. This can be done using another two, three or four tools depending on the spreading force required. Removal can then be achieved as follows:

1. Release all hydraulic pressure from the tool by turning the release valve anti-clockwise
2. Remove the hydraulic hose from the cylinder assembly
3. Unscrew the cylinder assembly from the collet holder
4. Unscrew the drive nut and remove the drive cone from the collet holder
5. Screw the drive nut back onto the collet holder until it is 1-2mm off the end
6. Using a hammer and a suitable drift, move the collet holder until it is possible to cut off the tapered end of the collet holder
7. Cut off the tapered end of the collet holder with a hacksaw or other cutting tool
8. Withdraw the collet holder from the bolt hole
9. Unscrew the drive nut and remove the drive cone from the spreading plug
10. Using a hammer and a suitable drift, move the spreading plug up to the collet and drive it out
11. Drive the remaining collet out using the spreading plug

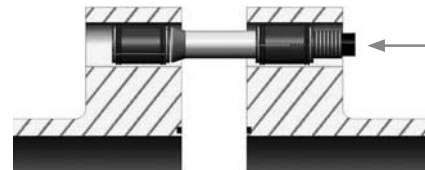
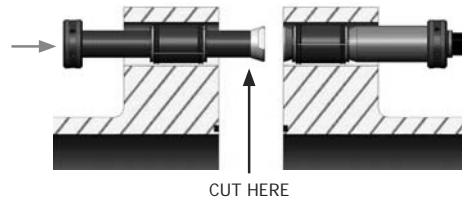



11. SECURE-GRIP TOOL RANGE

Collet identification	Tool type	Operation type	SWL (ton)	Min. bolt-hole diameter	Max. bolt-hole diameter
M16 5/8"	SG4TM	manual	4	17.5	19.5
M20 3/4"	SG4TM	manual	4	20.5	23
M24 7/8"	SG6TM	manual	6	24	26.5
M27 1"	SG6TM	manual	6	27.5	30
M30 1 1/8"	SG11TM	manual	11	30	33
M33 1 1/4"	SG11TM	manual	11	32	36
M36 1 3/8"	SG11TM	manual	11	35	39
M39 1 1/2"	SG13TE	hydraulic	13	38	42
M42 1 5/8"	SG13TE	hydraulic	13	41	45
M45 1 3/4"	SG13TE	hydraulic	13	44	49
M48 1 7/8"	SG15TE	hydraulic	15	47.5	52
M52 2"	SG15TE	hydraulic	15	50.5	56
M56 2 1/4"	SG15TE	hydraulic	15	55.5	62
M60	SG18TE	in-line hydraulic	18	59.5	63
M64 2 1/2"	SG18TE	in-line hydraulic	18	63	69
M70 2 3/4"	SG18TE	in-line hydraulic	18	69	75
M76 3"	SG25TE	in-line hydraulic	25	75	81
M80 3 1/4"	SG25TE	in-line hydraulic	25	79	86
M84	SG25TE	in-line hydraulic	25	83	88
M90 3 1/2"	SG25TE	in-line hydraulic	25	88	94
M95 3 3/4"	SG25TE	in-line hydraulic	25	94	101
M100 4"	SG25TE	in-line hydraulic	25	99	107



12. RANGE OF APPLICATION CHARTS

Use the charts on the following pages to determine which Secure-Grip tool (and which collet size) is suitable for a particular flange.

The charts are categorised as per flange type.

SPO		→	see page 29
ANSI	compact	→	see page 30
	orifice	→	see page 30
	reducing	→	see page 31
DIN	blind	→	see page 32
	threaded	→	see page 32
	weldneck	→	see page 33
	flat	→	see page 33
	lapped	→	see page 33
ASME	series A weld neck	→	see page 34
	series A lapped	→	see page 35
	series A socket welded	→	see page 35
	series B weld neck and blind	→	see page 35
API	6B weld neck	→	see page 36
	6B blind and threaded	→	see page 36
	6BX weld neck	→	see page 36
	6BX blind and test	→	see page 36
BS		→	see page 37



SPO

Nominal pipe size	Class															
	150		300		600		900		1500		2500		4500i			
	collet	tool	collet	tool	collet	tool	collet	tool	collet	tool	collet	tool	collet	tool		
1 1/2"														M16 5/8"	SG4TM	
2"														M16 5/8"	SG4TM	
2 1/2"														M20 3/4"	SG4TM	
3"														M24 7/8"	SG6TM	
4"														M27 1"	SG6TM	
5"														M27 1"	SG6TM	
6"														M30 1 1/8"	SG11TM	
8"			M16 5/8"	SG4TM	M16 5/8"	SG4TM	M20 3/4"	SG4TM	M27 1"	SG6TM	M36 1 3/8"	SG11TM	M39 1 1/2"	SG13TE	M39 1 1/2"	SG13TE
10"			M16 5/8"	SG4TM	M20 3/4"	SG4TM	M24 7/8"	SG6TM	M33 1 1/4"	SG11TM	M39 1 1/2"	SG13TE	M48 1 7/8"	SG15TE	M48 1 7/8"	SG15TE
12"			M16 5/8"	SG4TM	M24 7/8"	SG6TM	M27 1"	SG6TM	M33 1 1/4"	SG11TM	M45 1 3/4"	SG13TE	M48 1 7/8"	SG15TE	M48 1 7/8"	SG15TE
14"			M16 5/8"	SG4TM	M24 7/8"	SG6TM	M27 1"	SG6TM	M36 1 3/8"	SG11TM	M48 1 7/8"	SG15TE	M52 2"	SG15TE	M52 2"	SG15TE
16"	M16 5/8"	SG4TM	M20 3/4"	SG4TM	M27 1"	SG6TM	M30 1 1/8"	SG11TM	M39 1 1/2"	SG13TE	M60	SG18TE	M60	SG18TE	M60	SG18TE
18"	M16 5/8"	SG4TM	M20 3/4"	SG4TM	M30 1 1/8"	SG11TM	M33 1 1/4"	SG11TM	M45 1 3/4"	SG13TE	M60	SG18TE	M60	SG18TE	M64 2 1/2"	SG18TE
20"	M16 5/8"	SG4TM	M24 7/8"	SG6TM	M30 1 1/8"	SG11TM	M36 1 3/8"	SG11TM	M48 1 7/8"	SG15TE	M64 2 1/2"	SG18TE	M84	SG25TE	M84	SG25TE
22"	M16 5/8"	SG4TM	M24 7/8"	SG6TM	M33 1 1/4"	SG11TM	M39 1 1/2"	SG13TE	M52 2"	SG15TE	M76 3"	SG25TE	M90 3 1/2"	SG25TE	M90 3 1/2"	SG25TE
24"	M20 3/4"	SG4TM	M27 1"	SG6TM	M33 1 1/4"	SG11TM	M42 1 5/8"	SG13TE	M60	SG18TE	M84	SG25TE	M100 4"	SG25TE	M100 4"	SG25TE
26"	M20 3/4"	SG4TM	M27 1"	SG6TM	M33 1 1/4"	SG11TM	M45 1 3/4"	SG13TE	M60	SG18TE						
28"	M20 3/4"	SG4TM	M27 1"	SG6TM	M36 1 3/8"	SG11TM	M45 1 3/4"	SG13TE	M60	SG18TE						
30"	M20 3/4"	SG4TM	M30 1 1/8"	SG11TM	M36 1 3/8"	SG11TM	M48 1 7/8"	SG15TE	M64 2 1/2"	SG18TE						
32"	M20 3/4"	SG4TM	M30 1 1/8"	SG11TM	M39 1 1/2"	SG13TE	M52 2"	SG15TE	M64 2 1/2"	SG18TE						
34"	M20 3/4"	SG4TM	M33 1 1/4"	SG11TM	M39 1 1/2"	SG13TE	M60	SG18TE	M70 2 3/4"	SG18TE						
36"	M24 7/8"	SG6TM	M33 1 1/4"	SG11TM	M39 1 1/2"	SG13TE	M60	SG18TE	M84	SG25TE						
38"	M24 7/8"	SG6TM	M33 1 1/4"	SG11TM	M39 1 1/2"	SG13TE	M64 2 1/2"	SG18TE	M90 3 1/2"	SG25TE						
40"	M24 7/8"	SG6TM	M33 1 1/4"	SG11TM	M39 1 1/2"	SG13TE	M64 2 1/2"	SG18TE	M84	SG25TE						
42"	M24 7/8"	SG6TM	M36 1 3/8"	SG11TM	M48 1 7/8"	SG15TE	M64 2 1/2"	SG18TE	M95 3 3/4"	SG25TE						
44"	M24 7/8"	SG6TM	M36 1 3/8"	SG11TM	M48 1 7/8"	SG15TE	M64 2 1/2"	SG18TE	M95 3 3/4"	SG25TE						
46"	M24 7/8"	SG6TM	M39 1 1/2"	SG13TE	M48 1 7/8"	SG15TE	M70 2 3/4"	SG18TE	M95 3 3/4"	SG25TE						
48"	M24 7/8"	SG6TM	M39 1 1/2"	SG13TE	M48 1 7/8"	SG15TE	M76 3"	SG25TE	M95 3 3/4"	SG25TE						



ANSI compact

Nominal pipe size	Class									
	300		600		900		1500		2500	
	collet	tool	collet	tool	collet	tool	collet	tool	collet	tool
1"	no flange		no flange		no flange		no flange		no flange	
1 1/2"										
2"									M16 5/8"	SG4TM
2 1/2"	M16 5/8"	SG4TM	M16 5/8"	SG4TM	M16 5/8"	SG4TM	M16 5/8"	SG4TM	M24 7/8"	SG6TM
3"	M16 5/8"	SG4TM	M16 5/8"	SG4TM	M16 5/8"	SG4TM	M16 5/8"	SG4TM	M16 5/8"	SG4TM
4"	M20 3/4"	SG4TM	M20 3/4"	SG4TM	M20 3/4"	SG4TM	M20 3/4"	SG4TM	M20 3/4"	SG4TM
5"	M20 3/4"	SG4TM	M20 3/4"	SG4TM	M20 3/4"	SG4TM	M20 3/4"	SG4TM	M27 1"	SG6TM
6"	M20 3/4"	SG4TM	M20 3/4"	SG4TM	M20 3/4"	SG4TM	M24 7/8"	SG6TM	M30 1 1/8"	SG11TM
8"	M20 3/4"	SG4TM	M20 3/4"	SG4TM	M20 3/4"	SG4TM	M27 1"	SG6TM	M36 1 3/8"	SG11TM
10"	M20 3/4"	SG4TM	M20 3/4"	SG4TM	M27 1"	SG6TM	M30 1 1/8"	SG11TM	M45 1 3/4"	SG13TE
12"	M20 3/4"	SG4TM	M24 7/8"	SG6TM	M30 1 1/8"	SG11TM	M36 1 3/8"	SG11TM	M52 2"	SG15TE
14"	M20 3/4"	SG4TM	M27 1"	SG6TM	M33 1 1/4"	SG11TM	M36 1 3/8"	SG11TM	M45 1 3/4"	SG13TE
16"	M20 3/4"	SG4TM	M30 1 1/8"	SG11TM	M36 1 3/8"	SG11TM	M42 1 5/8"	SG13TE	M52 2"	SG15TE
18"	M24 7/8"	SG6TM	M33 1 1/4"	SG11TM	M36 1 3/8"	SG11TM	M45 1 3/4"	SG13TE	M56 2 1/4"	SG15TE
20"	M30 1 1/8"	SG11TM	M36 1 3/8"	SG11TM	M39 1 1/2"	SG13TE	M52 2"	SG15TE	M64 2 1/2"	SG18TE
24"	M30 1 1/8"	SG11TM	M39 1 1/2"	SG13TE	M45 1 3/4"	SG13TE	M56 2 1/4"	SG15TE	M64 2 1/2"	SG18TE
30"	M27 1"	SG6TM	M42 1 5/8"	SG13TE	M56 2 1/4"	SG15TE	M70 2 3/4"	SG18TE		
36"	M30 1 1/8"	SG11TM	M45 1 3/4"	SG13TE	M56 2 1/4"	SG15TE	M76 3"	SG25TE		
40"	M30 1 1/8"	SG11TM	M52 2"	SG15TE	M64 2 1/2"	SG18TE	M84	SG25TE		

ANSI orifice

Nominal pipe size	Class											
	300		400		600		900		1500		2500	
	collet	tool	collet	tool	collet	tool	collet	tool	collet	tool		
1"	M16 5/8"	SG4TM	M16 5/8"	SG4TM	M16 5/8"	SG4TM	M24 7/8"	SG6TM	M24 7/8"	SG6TM	M24 7/8"	SG6TM
1 1/2"	M20 3/4"	SG4TM	M20 3/4"	SG4TM	M20 3/4"	SG4TM	M27 1"	SG6TM	M27 1"	SG6TM	M30 1 1/8"	SG11TM
2"	M16 5/8"	SG4TM	M16 5/8"	SG4TM	M16 5/8"	SG4TM	M24 7/8"	SG6TM	M24 7/8"	SG6TM	M27 1"	SG6TM
2 1/2"	M20 3/4"	SG4TM	M20 3/4"	SG4TM	M20 3/4"	SG4TM	M27 1"	SG6TM	M27 1"	SG6TM	M30 1 1/8"	SG11TM
3"	M20 3/4"	SG4TM	M20 3/4"	SG4TM	M20 3/4"	SG4TM	M24 7/8"	SG6TM	M30 1 1/8"	SG11TM	M33 1 1/4"	SG11TM
4"	M20 3/4"	SG4TM	M24 7/8"	SG6TM	M24 7/8"	SG6TM	M30 1 1/8"	SG11TM	M33 1 1/4"	SG11TM	M39 1 1/2"	SG13TE
6"	M20 3/4"	SG4TM	M24 7/8"	SG6TM	M27 1"	SG6TM	M30 1 1/8"	SG11TM	M36 1 3/8"	SG11TM	M52 2"	SG15TE
8"	M24 7/8"	SG6TM	M27 1"	SG6TM	M30 1 1/8"	SG11TM	M36 1 3/8"	SG11TM	M42 1 5/8"	SG13TE	M52 2"	SG15TE
10"	M27 1"	SG6TM	M30 1 1/8"	SG11TM	M33 1 1/4"	SG11TM	M36 1 3/8"	SG11TM	M48 1 7/8"	SG15TE	M64 2 1/2"	SG18TE
12"	M30 1 1/8"	SG11TM	M33 1 1/4"	SG11TM	M33 1 1/4"	SG11TM	M36 1 3/8"	SG11TM	M52 2"	SG15TE	M70 2 3/4"	SG18TE
14"	M30 1 1/8"	SG11TM	M33 1 1/4"	SG11TM	M36 1 3/8"	SG11TM	M39 1 1/2"	SG13TE	M56 2 1/4"	SG15TE		
16"	M33 1 1/4"	SG11TM	M36 1 3/8"	SG11TM	M39 1 1/2"	SG13TE	M42 1 5/8"	SG13TE	M64 2 1/2"	SG18TE		
18"	M33 1 1/4"	SG11TM	M36 1 3/8"	SG11TM	M42 1 5/8"	SG13TE	M48 1 7/8"	SG15TE	M70 2 3/4"	SG18TE		
20"	M33 1 1/4"	SG11TM	M39 1 1/2"	SG13TE	M42 1 5/8"	SG13TE	M52 2"	SG15TE	M76 3"	SG25TE		
24"	M39 1 1/2"	SG13TE	M45 1 3/4"	SG13TE	M48 1 7/8"	SG15TE	M64 2 1/2"	SG18TE	M90 3 1/2"	SG25TE		



ANSI reducing

Nominal pipe size	Class														
	150		300		400		600		900		1500		2500		
	collet	tool	collet	tool	collet	tool	collet	tool	collet	tool	collet	tool	collet	tool	
1/2"										M20 3/4"	SG4TM	M20 3/4"	SG4TM	M20 3/4"	SG4TM
3/4"			M16 5/8"	SG4TM	M16 5/8"	SG4TM	M16 5/8"	SG4TM	M20 3/4"	SG4TM	M20 3/4"	SG4TM	M20 3/4"	SG4TM	
1"			M16 5/8"	SG4TM	M16 5/8"	SG4TM	M16 5/8"	SG4TM	M24 7/8"	SG6TM	M24 7/8"	SG6TM	M24 7/8"	SG6TM	
1 1/4"			M16 5/8"	SG4TM	M16 5/8"	SG4TM	M16 5/8"	SG4TM	M24 7/8"	SG6TM	M24 7/8"	SG6TM	M27 1"	SG6TM	
1 1/2"			M20 3/4"	SG4TM	M20 3/4"	SG4TM	M20 3/4"	SG4TM	M27 1"	SG6TM	M27 1"	SG6TM	M30 1 1/8"	SG11TM	
2"	M16 5/8"	SG4TM	M16 5/8"	SG4TM	M16 5/8"	SG4TM	M16 5/8"	SG4TM	M24 7/8"	SG6TM	M24 7/8"	SG6TM	M27 1"	SG6TM	
2 1/2"	M16 5/8"	SG4TM	M20 3/4"	SG4TM	M20 3/4"	SG4TM	M20 3/4"	SG4TM	M27 1"	SG6TM	M27 1"	SG6TM	M30 1 1/8"	SG11TM	
3"	M16 5/8"	SG4TM	M20 3/4"	SG4TM	M20 3/4"	SG4TM	M20 3/4"	SG4TM	M24 7/8"	SG6TM	M30 1 1/8"	SG11TM	M33 1 1/4"	SG11TM	
3 1/2"	M16 5/8"	SG4TM	M20 3/4"	SG4TM	M24 7/8"	SG6TM	M24 7/8"	SG6TM	no flange	no flange	no flange	no flange	no flange	no flange	
4"	M16 5/8"	SG4TM	M20 3/4"	SG4TM	M24 7/8"	SG6TM	M24 7/8"	SG6TM	M30 1 1/8"	SG11TM	M33 1 1/4"	SG11TM	M39 1 1/2"	SG13TE	
5"	M20 3/4"	SG4TM	M20 3/4"	SG4TM	M24 7/8"	SG6TM	M27 1"	SG6TM	M33 1 1/4"	SG11TM	M39 1 1/2"	SG13TE	M45 1 3/4"	SG13TE	
6"	M20 3/4"	SG4TM	M20 3/4"	SG4TM	M24 7/8"	SG6TM	M27 1"	SG6TM	M30 1 1/8"	SG11TM	M36 1 3/8"	SG11TM	M52 2"	SG15TE	
8"	M20 3/4"	SG4TM	M24 7/8"	SG6TM	M27 1"	SG6TM	M30 1 1/8"	SG11TM	M36 1 3/8"	SG11TM	M42 1 5/8"	SG13TE	M52 2"	SG15TE	
10"	M24 7/8"	SG6TM	M27 1"	SG6TM	M30 1 1/8"	SG11TM	M33 1 1/4"	SG11TM	M36 1 3/8"	SG11TM	M48 1 7/8"	SG15TE	M64 2 1/2"	SG18TE	
12"	M24 7/8"	SG6TM	M30 1 1/8"	SG11TM	M33 1 1/4"	SG11TM	M33 1 1/4"	SG11TM	M36 1 3/8"	SG11TM	M52 2"	SG15TE	M70 2 3/4"	SG18TE	
14"	M27 1"	SG6TM	M30 1 1/8"	SG11TM	M33 1 1/4"	SG11TM	M36 1 3/8"	SG11TM	M39 1 1/2"	SG13TE	M56 2 1/4"	SG15TE			
16"	M27 1"	SG6TM	M33 1 1/4"	SG11TM	M36 1 3/8"	SG11TM	M39 1 1/2"	SG13TE	M42 1 5/8"	SG13TE	M64 2 1/2"	SG18TE			
18"	M30 1 1/8"	SG11TM	M33 1 1/4"	SG11TM	M36 1 3/8"	SG11TM	M42 1 5/8"	SG13TE	M48 1 7/8"	SG15TE	M70 2 3/4"	SG18TE			
20"	M30 1 1/8"	SG11TM	M33 1 1/4"	SG11TM	M39 1 1/2"	SG13TE	M42 1 5/8"	SG13TE	M52 2"	SG15TE	M76 3"	SG25TE			
22"	no flange		no flange		no flange		no flange		no flange		no flange				
24"	M33 1 1/4"	SG11TM	M39 1 1/2"	SG13TE	M45 1 3/4"	SG13TE	M48 1 7/8"	SG15TE	M64 2 1/2"	SG18TE	M90 3 1/2"	SG25TE			
26"	M33 1 1/4"	SG11TM	M42 1 5/8"	SG13TE	M42 1 5/8"	SG13TE	M48 1 7/8"	SG15TE	M70 2 3/4"	SG18TE					
28"	M33 1 1/4"	SG11TM	M42 1 5/8"	SG13TE	M42 1 5/8"	SG13TE	M52 2"	SG15TE	M76 3"	SG25TE					
30"	M33 1 1/4"	SG11TM	M45 1 3/4"	SG13TE	M45 1 3/4"	SG13TE	M56 2 1/4"	SG15TE	M76 3"	SG25TE					
32"	M39 1 1/2"	SG13TE	M48 1 7/8"	SG15TE	M48 1 7/8"	SG15TE	M56 2 1/4"	SG15TE	M84	SG25TE					
34"	M39 1 1/2"	SG13TE	M48 1 7/8"	SG15TE	M48 1 7/8"	SG15TE	M56 2 1/4"	SG15TE	M90 3 1/2"	SG25TE					
36"	M39 1 1/2"	SG13TE	M52 2"	SG15TE	M52 2"	SG15TE	M56 2 1/4"	SG15TE	M90 3 1/2"	SG25TE					
38"	M39 1 1/2"	SG13TE	M39 1 1/2"	SG13TE	M39 1 1/2"	SG13TE	M56 2 1/4"	SG15TE	M90 3 1/2"	SG25TE					
40"	M39 1 1/2"	SG13TE	M42 1 5/8"	SG13TE	M42 1 5/8"	SG13TE	M56 2 1/4"	SG15TE	M90 3 1/2"	SG25TE					
42"	M39 1 1/2"	SG13TE	M42 1 5/8"	SG13TE	M42 1 5/8"	SG13TE	M56 2 1/4"	SG15TE	M90 3 1/2"	SG25TE					
44"	M39 1 1/2"	SG13TE	M45 1 3/4"	SG13TE	M45 1 3/4"	SG13TE	M56 2 1/4"	SG15TE	M95 3 3/4"	SG25TE					
46"	M39 1 1/2"	SG13TE	M48 1 7/8"	SG15TE	M48 1 7/8"	SG15TE	M56 2 1/4"	SG15TE	M100 4"	SG25TE					
48"	M39 1 1/2"	SG13TE	M48 1 7/8"	SG15TE	M48 1 7/8"	SG15TE	M70 2 3/4"	SG18TE	M100 4"	SG25TE					



DIN blind

Nominal pipe size	Class									
	PN16		PN25		PN40		PN64		PN100	
	collet	tool	collet	tool	collet	tool	collet	tool	collet	tool
3/4"							no flange		no flange	
1"							M16 5/8"	SG4TM	M16 5/8"	SG4TM
1 1/4"	M16 5/8"	SG4TM	M16 5/8"	SG4TM	M16 5/8"	SG4TM	M20 3/4"	SG4TM	M20 3/4"	SG4TM
1 1/2"	M16 5/8"	SG4TM	M16 5/8"	SG4TM	M16 5/8"	SG4TM	M20 3/4"	SG4TM	M20 3/4"	SG4TM
2"	M16 5/8"	SG4TM	M16 5/8"	SG4TM	M16 5/8"	SG4TM	M20 3/4"	SG4TM	M24 7/8"	SG6TM
2 1/2"	M16 5/8"	SG4TM	M16 5/8"	SG4TM	M16 5/8"	SG4TM	M20 3/4"	SG4TM	M24 7/8"	SG6TM
3"	M16 5/8"	SG4TM	M16 5/8"	SG4TM	M16 5/8"	SG4TM	M20 3/4"	SG4TM	M24 7/8"	SG6TM
4"	M16 5/8"	SG4TM	M20 3/4"	SG4TM	M20 3/4"	SG4TM	M24 7/8"	SG6TM	M27 1"	SG6TM
5"	M16 5/8"	SG4TM	M24 7/8"	SG6TM	M24 7/8"	SG6TM	M27 1"	SG6TM	M30 1 1/8"	SG11TM
6"	M20 3/4"	SG4TM	M24 7/8"	SG6TM	M24 7/8"	SG6TM	M30 1 1/8"	SG11TM	M30 1 1/8"	SG11TM
7"	M20 3/4"	SG4TM	M24 7/8"	SG6TM	M27 1"	SG6TM	M30 1 1/8"	SG11TM	M30 1 1/8"	SG11TM
8"	M20 3/4"	SG4TM	M24 7/8"	SG6TM	M27 1"	SG6TM	M33 1 1/4"	SG11TM	M33 1 1/4"	SG11TM
10"	M24 7/8"	SG6TM	M27 1"	SG6TM	M30 1 1/8"	SG11TM	M33 1 1/4"	SG11TM	M36 1 3/8"	SG11TM
12"	M24 7/8"	SG6TM	M27 1"	SG6TM	M30 1 1/8"	SG11TM	M33 1 1/4"	SG11TM	M39 1 1/2"	SG13TE
14"	M24 7/8"	SG6TM	M30 1 1/8"	SG11TM	M33 1 1/4"	SG11TM	M36 1 3/8"	SG11TM	M45 1 3/4"	SG13TE
16"	M27 1"	SG6TM	M33 1 1/4"	SG11TM	M36 1 3/8"	SG11TM	M39 1 1/2"	SG13TE		
20"	M30 1 1/8"	SG11TM	M33 1 1/4"	SG11TM	M39 1 1/2"	SG13TE				

DIN threaded

Nominal pipe size	Class									
	PN16		PN25		PN40		PN64		PN100	
	collet	tool	collet	tool	collet	tool	collet	tool	collet	tool
3/4"									M16 5/8"	SG4TM
1"									M16 5/8"	SG4TM
1 1/4"	M16 5/8"	SG4TM	M16 5/8"	SG4TM	M16 5/8"	SG4TM	M16 5/8"	SG4TM	M20 3/4"	SG4TM
1 1/2"	M16 5/8"	SG4TM	M16 5/8"	SG4TM	M16 5/8"	SG4TM	M16 5/8"	SG4TM	M20 3/4"	SG4TM
2"	M16 5/8"	SG4TM	M16 5/8"	SG4TM	M16 5/8"	SG4TM	M20 3/4"	SG4TM	M24 7/8"	SG6TM
2 1/2"	M16 5/8"	SG4TM	M16 5/8"	SG4TM	M16 5/8"	SG4TM	M20 3/4"	SG4TM	M24 7/8"	SG6TM
3"	M16 5/8"	SG4TM	M16 5/8"	SG4TM	M16 5/8"	SG4TM	M20 3/4"	SG4TM	M24 7/8"	SG6TM
4"	M16 5/8"	SG4TM	M20 3/4"	SG4TM	M20 3/4"	SG4TM	M24 7/8"	SG6TM	M27 1"	SG6TM
5"	M16 5/8"	SG4TM	M24 7/8"	SG6TM	M24 7/8"	SG6TM	M24 7/8"	SG6TM	M30 1 1/8"	SG11TM
6"	M16 5/8"	SG4TM	M24 7/8"	SG6TM	M24 7/8"	SG6TM	M30 1 1/8"	SG11TM	M30 1 1/8"	SG11TM



DIN weldneck

Nominal pipe size	Class											
	PN16		PN25		PN40		PN64		PN100		PN160	
	collet	tool	collet	tool	collet	tool	collet	tool	collet	tool	collet	tool
1"							M16 5/8"	SG4TM	M16 5/8"	SG4TM	M16 5/8"	SG4TM
1 1/4"	M16 5/8"	SG4TM	M16 5/8"	SG4TM	M16 5/8"	SG4TM						
1 1/2"	M16 5/8"	SG4TM	M16 5/8"	SG4TM	M16 5/8"	SG4TM	M20 3/4"	SG4TM	M20 3/4"	SG4TM	M20 3/4"	SG4TM
2"	M16 5/8"	SG4TM	M16 5/8"	SG4TM	M16 5/8"	SG4TM	M20 3/4"	SG4TM	M24 7/8"	SG6TM	M24 7/8"	SG6TM
2 1/2"	M16 5/8"	SG4TM	M16 5/8"	SG4TM	M16 5/8"	SG4TM	M20 3/4"	SG4TM	M24 7/8"	SG6TM	M24 7/8"	SG6TM
3"	M16 5/8"	SG4TM	M16 5/8"	SG4TM	M16 5/8"	SG4TM	M20 3/4"	SG4TM	M24 7/8"	SG6TM	M24 7/8"	SG6TM
4"	M16 5/8"	SG4TM	M16 5/8"	SG4TM	M16 5/8"	SG4TM	M24 7/8"	SG6TM	M27 1"	SG6TM	M27 1"	SG6TM
5"	M16 5/8"	SG4TM	M16 5/8"	SG4TM	M16 5/8"	SG4TM	M27 1"	SG6TM	M30 1 1/8"	SG11TM	M30 1 1/8"	SG11TM
6"	M20 3/4"	SG4TM	M20 3/4"	SG4TM	M20 3/4"	SG4TM	M30 1 1/8"	SG11TM	M30 1 1/8"	SG11TM	M30 1 1/8"	SG11TM
7"	M20 3/4"	SG4TM	M24 7/8"	SG6TM	M20 3/4"	SG4TM	M30 1 1/8"	SG11TM	M30 1 1/8"	SG11TM	M33 1 1/4"	SG11TM
8"	M20 3/4"	SG4TM	M24 7/8"	SG6TM	M20 3/4"	SG4TM	M33 1 1/4"	SG11TM	M33 1 1/4"	SG11TM	M33 1 1/4"	SG11TM
10"	M24 7/8"	SG6TM	M27 1"	SG6TM	M24 7/8"	SG6TM	M33 1 1/4"	SG11TM	M36 1 3/8"	SG11TM	M39 1 1/2"	SG13TE
12"	M24 7/8"	SG6TM	M27 1"	SG6TM	M24 7/8"	SG6TM	M33 1 1/4"	SG11TM	M39 1 1/2"	SG13TE	M39 1 1/2"	SG13TE
14"	M24 7/8"	SG6TM	M30 1 1/8"	SG11TM	M24 7/8"	SG6TM	M36 1 3/8"	SG11TM	M45 1 3/4"	SG13TE		
16"	M27 1"	SG6TM	M33 1 1/4"	SG11TM	M27 1"	SG6TM	M39 1 1/2"	SG13TE				
18"	M27 1"	SG6TM	M33 1 1/4"	SG11TM	M27 1"	SG6TM						
20"	M30 1 1/8"	SG11TM	M33 1 1/4"	SG11TM	M30 1 1/8"	SG11TM						
24"	M33 1 1/4"	SG11TM	M36 1 3/8"	SG11TM								
28"	M33 1 1/4"	SG11TM	M39 1 1/2"	SG13TE								
32"	M36 1 3/8"	SG11TM	M45 1 3/4"	SG13TE								
36"	M36 1 3/8"	SG11TM	M45 1 3/4"	SG13TE								
40"	M39 1 1/2"	SG13TE	M52 2"	SG15TE								
48"	M45 1 3/4"	SG13TE										
56"	M45 1 3/4"	SG13TE										
64"	M52 2"	SG15TE										
72"	M52 2"	SG15TE										
80"	M56 2 1/4"	SG15TE										

DIN flat

Nominal pipe size	Class			
	PN6		PN10	
	collet	tool	collet	tool
1 1/4"			M16 5/8"	SG4TM
1 1/2"			M16 5/8"	SG4TM
2"			M16 5/8"	SG4TM
2 1/2"			M16 5/8"	SG4TM
3"	M16 5/8"	SG4TM	M16 5/8"	SG4TM
4"	M16 5/8"	SG4TM	M16 5/8"	SG4TM
5"	M16 5/8"	SG4TM	M16 5/8"	SG4TM
6"	M16 5/8"	SG4TM	M20 3/4"	SG4TM
8"	M16 5/8"	SG4TM	M20 3/4"	SG4TM
10"	M16 5/8"	SG4TM	M20 3/4"	SG4TM
12"	M20 3/4"	SG4TM	M20 3/4"	SG4TM
14"	M20 3/4"	SG4TM	M20 3/4"	SG4TM
16"	M20 3/4"	SG4TM	M24 7/8"	SG6TM
18"	M20 3/4"	SG4TM	M24 7/8"	SG6TM
20"	M20 3/4"	SG4TM	M24 7/8"	SG6TM

DIN lapped

Nominal pipe size	Class			
	PN6		PN10	
	collet	tool	collet	tool
1 1/4"			M16 5/8"	SG4TM
1 1/2"			M16 5/8"	SG4TM
2"			M16 5/8"	SG4TM
2 1/2"			M16 5/8"	SG4TM
3"	M16 5/8"	SG4TM	M16 5/8"	SG4TM
4"	M16 5/8"	SG4TM	M16 5/8"	SG4TM
5"	M16 5/8"	SG4TM	M16 5/8"	SG4TM
6"	M16 5/8"	SG4TM	M20 3/4"	SG4TM
8"	M16 5/8"	SG4TM	M20 3/4"	SG4TM
10"	M16 5/8"	SG4TM	M20 3/4"	SG4TM
12"	M20 3/4"	SG4TM	M20 3/4"	SG4TM
14"	M20 3/4"	SG4TM	M20 3/4"	SG4TM
16"	M20 3/4"	SG4TM	M24 7/8"	SG6TM
18"	M20 3/4"	SG4TM	M24 7/8"	SG6TM
20"	M20 3/4"	SG4TM	M24 7/8"	SG6TM
24"	M24 7/8"	SG6TM	M27 1"	SG6TM
28"	M24 7/8"	SG6TM	M27 1"	SG6TM
32"	M27 1"	SG6TM	M30 1 1/8"	SG11TM
36"	M27 1"	SG6TM		
40"	M27 1"	SG6TM		



ASME series A weld neck

Nominal pipe size	Class														
	150		300		400		600		900		1500		2500		
	collet	tool	collet	tool	collet	tool	collet	tool	collet	tool	collet	tool	collet	tool	
1/2"										M20 3/4"	SG4TM	M20 3/4"	SG4TM	M20 3/4"	SG4TM
3/4"			M16 5/8"	SG4TM	M16 5/8"	SG4TM	M16 5/8"	SG4TM	M20 3/4"	SG4TM	M20 3/4"	SG4TM	M20 3/4"	SG4TM	
1"			M16 5/8"	SG4TM	M16 5/8"	SG4TM	M16 5/8"	SG4TM	M24 7/8"	SG6TM	M24 7/8"	SG6TM	M24 7/8"	SG6TM	
1 1/4"			M16 5/8"	SG4TM	M16 5/8"	SG4TM	M16 5/8"	SG4TM	M24 7/8"	SG6TM	M24 7/8"	SG6TM	M27 1"	SG6TM	
1 1/2"			M20 3/4"	SG4TM	M20 3/4"	SG4TM	M20 3/4"	SG4TM	M27 1"	SG6TM	M27 1"	SG6TM	M30 1 1/8"	SG11TM	
2"	M16 5/8"	SG4TM	M16 5/8"	SG4TM	M16 5/8"	SG4TM	M16 5/8"	SG4TM	M24 7/8"	SG6TM	M24 7/8"	SG6TM	M27 1"	SG6TM	
2 1/2"	M16 5/8"	SG4TM	M20 3/4"	SG4TM	M20 3/4"	SG4TM	M20 3/4"	SG4TM	M27 1"	SG6TM	M27 1"	SG6TM	M30 1 1/8"	SG11TM	
3"	M16 5/8"	SG4TM	M20 3/4"	SG4TM	M20 3/4"	SG4TM	M20 3/4"	SG4TM	M24 7/8"	SG6TM	M30 1 1/8"	SG11TM	M33 1 1/4"	SG11TM	
3 1/2"	M16 5/8"	SG4TM	M20 3/4"	SG4TM	M24 7/8"	SG6TM	M24 7/8"	SG6TM							
4"	M16 5/8"	SG4TM	M20 3/4"	SG4TM	M24 7/8"	SG6TM	M24 7/8"	SG6TM	M30 1 1/8"	SG11TM	M33 1 1/4"	SG11TM	M39 1 1/2"	SG13TE	
5"	M20 3/4"	SG4TM	M20 3/4"	SG4TM	M24 7/8"	SG6TM	M27 1"	SG6TM	M33 1 1/4"	SG11TM	M39 1 1/2"	SG13TE	M45 1 3/4"	SG13TE	
6"	M20 3/4"	SG4TM	M20 3/4"	SG4TM	M24 7/8"	SG6TM	M27 1"	SG6TM	M30 1 1/8"	SG11TM	M36 1 3/8"	SG11TM	M52 2"	SG15TE	
8"	M20 3/4"	SG4TM	M24 7/8"	SG6TM	M27 1"	SG6TM	M30 1 1/8"	SG11TM	M36 1 3/8"	SG11TM	M42 1 5/8"	SG13TE	M52 2"	SG15TE	
10"	M24 7/8"	SG6TM	M27 1"	SG6TM	M30 1 1/8"	SG11TM	M33 1 1/4"	SG11TM	M36 1 3/8"	SG11TM	M48 1 7/8"	SG15TE	M64 2 1/2"	SG18TE	
12"	M24 7/8"	SG6TM	M30 1 1/8"	SG11TM	M33 1 1/4"	SG11TM	M33 1 1/4"	SG11TM	M36 1 3/8"	SG11TM	M52 2"	SG15TE	M70 2 3/4"	SG18TE	
14"	M27 1"	SG6TM	M30 1 1/8"	SG11TM	M33 1 1/4"	SG11TM	M36 1 3/8"	SG11TM	M39 1 1/2"	SG13TE	M56 2 1/4"	SG15TE			
16"	M27 1"	SG6TM	M33 1 1/4"	SG11TM	M36 1 3/8"	SG11TM	M39 1 1/2"	SG13TE	M42 1 5/8"	SG13TE	M64 2 1/2"	SG18TE			
18"	M30 1 1/8"	SG11TM	M33 1 1/4"	SG11TM	M36 1 3/8"	SG11TM	M42 1 5/8"	SG13TE	M48 1 7/8"	SG15TE	M70 2 3/4"	SG18TE			
20"	M30 1 1/8"	SG11TM	M33 1 1/4"	SG11TM	M39 1 1/2"	SG13TE	M42 1 5/8"	SG13TE	M52 2"	SG15TE	M76 3"	SG25TE			
22"															
24"	M33 1 1/4"	SG11TM	M39 1 1/2"	SG13TE	M45 1 3/4"	SG13TE	M48 1 7/8"	SG15TE	M64 2 1/2"	SG18TE	M90 3 1/2"	SG25TE			
26"	M33 1 1/4"	SG11TM	M42 1 5/8"	SG13TE	M42 1 5/8"	SG13TE	M48 1 7/8"	SG15TE	M70 2 3/4"	SG18TE					
28"	M33 1 1/4"	SG11TM	M42 1 5/8"	SG13TE	M42 1 5/8"	SG13TE	M52 2"	SG15TE	M76 3"	SG25TE					
30"	M33 1 1/4"	SG11TM	M45 1 3/4"	SG13TE	M45 1 3/4"	SG13TE	M56 2 1/4"	SG15TE	M76 3"	SG25TE					
32"	M39 1 1/2"	SG13TE	M48 1 7/8"	SG15TE	M48 1 7/8"	SG15TE	M56 2 1/4"	SG15TE	M84	SG25TE					
34"	M39 1 1/2"	SG13TE	M48 1 7/8"	SG15TE	M48 1 7/8"	SG15TE	M56 2 1/4"	SG15TE	M90 3 1/2"	SG25TE					
36"	M39 1 1/2"	SG13TE	M52 2"	SG15TE	M52 2"	SG15TE	M56 2 1/4"	SG15TE	M90 3 1/2"	SG25TE					
38"	M39 1 1/2"	SG13TE	M39 1 1/2"	SG13TE	M39 1 1/2"	SG13TE	M56 2 1/4"	SG15TE	M90 3 1/2"	SG25TE					
40"	M39 1 1/2"	SG13TE	M42 1 5/8"	SG13TE	M42 1 5/8"	SG13TE	M56 2 1/4"	SG15TE	M90 3 1/2"	SG25TE					
42"	M39 1 1/2"	SG13TE	M42 1 5/8"	SG13TE	M42 1 5/8"	SG13TE	M56 2 1/4"	SG15TE	M90 3 1/2"	SG25TE					
44"	M39 1 1/2"	SG13TE	M45 1 3/4"	SG13TE	M45 1 3/4"	SG13TE	M56 2 1/4"	SG15TE	M95 3 3/4"	SG25TE					
46"	M39 1 1/2"	SG13TE	M48 1 7/8"	SG15TE	M48 1 7/8"	SG15TE	M56 2 1/4"	SG15TE	M100 4"	SG25TE					
48"	M39 1 1/2"	SG13TE	M48 1 7/8"	SG15TE	M48 1 7/8"	SG15TE	M70 2 3/4"	SG18TE	M100 4"	SG25TE					



ASME series A lapped

Nominal pipe size	Class													
	150		300		400		600		900		1500		2500	
	collet	tool	collet	tool	collet	tool	collet	tool	collet	tool	collet	tool	collet	tool
1/2"									M20 3/4"	SG4TM	M20 3/4"	SG4TM	M20 3/4"	SG4TM
3/4"			M16 5/8"	SG4TM	M16 5/8"	SG4TM	M16 5/8"	SG4TM	M20 3/4"	SG4TM	M20 3/4"	SG4TM	M20 3/4"	SG4TM
1"			M16 5/8"	SG4TM	M16 5/8"	SG4TM	M16 5/8"	SG4TM	M24 7/8"	SG6TM	M24 7/8"	SG6TM	M24 7/8"	SG6TM
1 1/4"			M16 5/8"	SG4TM	M16 5/8"	SG4TM	M16 5/8"	SG4TM	M24 7/8"	SG6TM	M24 7/8"	SG6TM	M27 1"	SG6TM
1 1/2"			M20 3/4"	SG4TM	M20 3/4"	SG4TM	M20 3/4"	SG4TM	M27 1"	SG6TM	M27 1"	SG6TM	M30 1 1/8"	SG11TM
2"	M16 5/8"	SG4TM	M16 5/8"	SG4TM	M16 5/8"	SG4TM	M16 5/8"	SG4TM	M24 7/8"	SG6TM	M24 7/8"	SG6TM	M27 1"	SG6TM
2 1/2"	M16 5/8"	SG4TM	M20 3/4"	SG4TM	M20 3/4"	SG4TM	M20 3/4"	SG4TM	M27 1"	SG6TM	M27 1"	SG6TM	M30 1 1/8"	SG11TM
3"	M16 5/8"	SG4TM	M20 3/4"	SG4TM	M20 3/4"	SG4TM	M20 3/4"	SG4TM	M24 7/8"	SG6TM	M30 1 1/8"	SG11TM	M33 1 1/4"	SG11TM
3 1/2"	M16 5/8"	SG4TM	M20 3/4"	SG4TM	M24 7/8"	SG6TM	M24 7/8"	SG6TM	no flange		no flange		no flange	
4"	M16 5/8"	SG4TM	M20 3/4"	SG4TM	M24 7/8"	SG6TM	M24 7/8"	SG6TM	M30 1 1/8"	SG11TM	M33 1 1/4"	SG11TM	M39 1 1/2"	SG13TE
5"	M20 3/4"	SG4TM	M20 3/4"	SG4TM	M24 7/8"	SG6TM	M27 1"	SG6TM	M33 1 1/4"	SG11TM	M39 1 1/2"	SG13TE	M45 1 3/4"	SG13TE
6"	M20 3/4"	SG4TM	M20 3/4"	SG4TM	M24 7/8"	SG6TM	M27 1"	SG6TM	M30 1 1/8"	SG11TM	M36 1 3/8"	SG11TM	M52 2"	SG15TE
8"	M20 3/4"	SG4TM	M24 7/8"	SG6TM	M27 1"	SG6TM	M30 1 1/8"	SG11TM	M36 1 3/8"	SG11TM	M42 1 5/8"	SG13TE	M52 2"	SG15TE
10"	M24 7/8"	SG6TM	M27 1"	SG6TM	M30 1 1/8"	SG11TM	M33 1 1/4"	SG11TM	M36 1 3/8"	SG11TM	M48 1 7/8"	SG15TE	M64 2 1/2"	SG18TE
12"	M24 7/8"	SG6TM	M30 1 1/8"	SG11TM	M33 1 1/4"	SG11TM	M33 1 1/4"	SG11TM	M36 1 3/8"	SG11TM	M52 2"	SG15TE	M70 2 3/4"	SG18TE

ASME series A socket welded

Nominal pipe size	Class							
	150		300		600		1500	
	collet	tool	collet	tool	collet	tool	collet	tool
1/2"							M20 3/4"	SG4TM
3/4"			M16 5/8"	SG4TM	M16 5/8"	SG4TM	M20 3/4"	SG4TM
1"			M16 5/8"	SG4TM	M16 5/8"	SG4TM	M24 7/8"	SG6TM
1 1/4"			M16 5/8"	SG4TM	M16 5/8"	SG4TM	M24 7/8"	SG6TM
1 1/2"			M20 3/4"	SG4TM	M20 3/4"	SG4TM	M27 1"	SG6TM
2"	M16 5/8"	SG4TM	M16 5/8"	SG4TM	M16 5/8"	SG4TM	M24 7/8"	SG6TM
2 1/2"	M16 5/8"	SG4TM	M20 3/4"	SG4TM	M20 3/4"	SG4TM	M27 1"	SG6TM
3"	M16 5/8"	SG4TM	M20 3/4"	SG4TM	M20 3/4"	SG4TM		

ASME series B weld neck and blind

Nominal pipe size	Class									
	150		300		400		600		900	
	collet	tool	collet	tool	collet	tool	collet	tool	collet	tool
26"	M20 3/4"	SG4TM	M33 1 1/4"	SG11TM	M36 1 3/8"	SG11TM	M42 1 5/8"	SG13TE	M64 2 1/2"	SG18TE
28"	M20 3/4"	SG4TM	M33 1 1/4"	SG11TM	M39 1 1/2"	SG13TE	M45 1 3/4"	SG13TE	M70 2 3/4"	SG18TE
30"	M20 3/4"	SG4TM	M36 1 3/8"	SG11TM	M39 1 1/2"	SG13TE	M48 1 7/8"	SG15TE	M76 3"	SG25TE
32"	M20 3/4"	SG4TM	M39 1 1/2"	SG13TE	M42 1 5/8"	SG13TE	M52 2"	SG15TE	M76 3"	SG25TE
34"	M24 7/8"	SG6TM	M39 1 1/2"	SG13TE	M42 1 5/8"	SG13TE	M56 2 1/4"	SG15TE	M80 3 1/4"	SG25TE
36"	M24 7/8"	SG6TM	M42 1 5/8"	SG13TE	M45 1 3/4"	SG13TE	M56 2 1/4"	SG15TE	M76 3"	SG25TE
42"	M27 1"	SG6TM	M45 1 3/4"	SG13TE						
48"	M30 1 1/8"	SG11TM	M48 1 7/8"	SG15TE						
54"	M30 1 1/8"	SG11TM	M48 1 7/8"	SG15TE						
60"	M33 1 1/4"	SG11TM	M56 2 1/4"	SG15TE						



API 6B weld neck

Nominal pipe size	Class					
	138 bar (2000 psi)		207 bar (3000 psi)		345 bar (5000 psi)	
	collet	tool	collet	tool	collet	tool
2 1/16"	M16 5/8"	SG4TM	M24 7/8"	SG6TM	M24 7/8"	SG6TM
2 9/16"	M20 3/4"	SG4TM	M27 1"	SG6TM	M27 1"	SG6TM
3 1/8"	M20 3/4"	SG4TM	M24 7/8"	SG6TM	M30 1 1/8"	SG11TM
4 1/16"	M24 7/8"	SG6TM	M30 1 1/8"	SG11TM	M33 1 1/4"	SG11TM
5 1/8"	M27 1"	SG6TM	M33 1 1/4"	SG11TM	M39 1 1/2"	SG13TE
7 1/16"	M27 1"	SG6TM	M30 1 1/8"	SG11TM	M36 1 3/8"	SG11TM
9"	M30 1 1/8"	SG11TM	M36 1 3/8"	SG11TM	M42 1 5/8"	SG13TE
11"	M33 1 1/4"	SG11TM	M36 1 3/8"	SG11TM	M48 1 7/8"	SG15TE

API 6B blind and threaded

Nominal pipe size	Class					
	138 bar (2000 psi)		207 bar (3000 psi)		345 bar (5000 psi)	
	collet	tool	collet	tool	collet	tool
2 1/16"	M16 5/8"	SG4TM	M24 7/8"	SG6TM	M24 7/8"	SG6TM
2 9/16"	M20 3/4"	SG4TM	M27 1"	SG6TM	M27 1"	SG6TM
3 1/8"	M20 3/4"	SG4TM	M24 7/8"	SG6TM	M30 1 1/8"	SG11TM
4 1/16"	M24 7/8"	SG6TM	M30 1 1/8"	SG11TM	M33 1 1/4"	SG11TM
5 1/8"	M27 1"	SG6TM	M33 1 1/4"	SG11TM	M39 1 1/2"	SG13TE
7 1/16"	M27 1"	SG6TM	M30 1 1/8"	SG11TM	M36 1 3/8"	SG11TM
9"	M30 1 1/8"	SG11TM	M36 1 3/8"	SG11TM	M42 1 5/8"	SG13TE
11"	M33 1 1/4"	SG11TM	M36 1 3/8"	SG11TM	M48 1 7/8"	SG15TE
13 5/8"	M33 1 1/4"	SG11TM	M36 1 3/8"	SG11TM		
16 3/4"	M39 1 1/2"	SG13TE	M42 1 5/8"	SG13TE		
21 1/4"	M42 1 5/8"	SG13TE	M52 2"	SG15TE		

API 6BX weld neck

Nominal pipe size	Class					
	690 bar (10000 psi)		1035 bar (15000 psi)		1380 bar (20000 psi)	
	collet	tool	collet	tool	collet	tool
1 13/16"	M20 3/4"	SG4TM	M24 7/8"	SG6TM	M27 1"	SG6TM
2 1/16"	M20 3/4"	SG4TM	M24 7/8"	SG6TM	M30 1 1/8"	SG11TM
2 9/16"	M24 7/8"	SG6TM	M27 1"	SG6TM	M33 1 1/4"	SG11TM
3 1/16"	M27 1"	SG6TM	M30 1 1/8"	SG11TM	M36 1 3/8"	SG11TM
4 1/16"	M30 1 1/8"	SG11TM	M36 1 3/8"	SG11TM	M45 1 3/4"	SG13TE
5 1/8"	M30 1 1/8"	SG11TM				
7 1/16"	M39 1 1/2"	SG13TE	M39 1 1/2"	SG13TE	M52 2"	SG15TE
9"	M39 1 1/2"	SG13TE				
11"	M45 1 3/4"	SG13TE				
13 5/8"	M48 1 7/8"	SG15TE				
16 3/4"	M48 1 7/8"	SG15TE				

API 6BX blind and test

Nominal pipe size	Class					
	690 bar (10000 psi)		1035 bar (15000 psi)		1380 bar (20000 psi)	
	collet	tool	collet	tool	collet	tool
1 13/16"	M20 3/4"	SG4TM	M24 7/8"	SG6TM	M27 1"	SG6TM
2 1/16"	M20 3/4"	SG4TM	M24 7/8"	SG6TM	M30 1 1/8"	SG11TM
2 9/16"	M24 7/8"	SG6TM	M27 1"	SG6TM	M33 1 1/4"	SG11TM
3 1/16"	M27 1"	SG6TM	M33 1 1/4"	SG11TM	M36 1 3/8"	SG11TM
4 1/16"	M30 1 1/8"	SG11TM	M42 1 5/8"	SG13TE	M45 1 3/4"	SG13TE



BS APPLICATION CHART

Nominal pipe size	A		D		E		F		H		J		K		R		S		T		
	collet	tool	collet	tool	collet	tool	collet	tool	collet	tool	collet	tool	collet	tool	collet	tool	collet	tool	collet	tool	
1/2"																					
3/4"																					
1"								M16 5/8"		M16 5/8"		M16 5/8"		M16 5/8"		M16 5/8"		M20 3/4"		M20 3/4"	
1 1/4"								M16 5/8"		M16 5/8"		M16 5/8"		M16 5/8"		M16 5/8"		M20 3/4"		M20 3/4"	
1 1/2"								M16 5/8"		M16 5/8"		M16 5/8"		M16 5/8"		M16 5/8"		M20 3/4"		M20 3/4"	
2"								M16 5/8"		M16 5/8"		M20 3/4"		M20 3/4"		M20 3/4"		M20 3/4"		M20 3/4"	
2 1/2"								M16 5/8"		M16 5/8"		M20 3/4"		M20 3/4"		M20 3/4"		M24 7/8"		M24 7/8"	
3"								M16 5/8"		M16 5/8"		M20 3/4"		M20 3/4"		M20 3/4"		M24 7/8"		M24 7/8"	
3 1/2"								M16 5/8"		M16 5/8"		M20 3/4"		M20 3/4"		M20 3/4"		M24 7/8"		M24 7/8"	
4"								M16 5/8"		M16 5/8"		M20 3/4"		M20 3/4"		M20 3/4"		M24 7/8"		M24 7/8"	
4 1/2"								M16 5/8"		M16 5/8"		M20 3/4"		M20 3/4"		M20 3/4"		M24 7/8"		M24 7/8"	
5"								M16 5/8"		M16 5/8"		M20 3/4"		M20 3/4"		M20 3/4"		M24 7/8"		M24 7/8"	
6"								M20 3/4"		M20 3/4"		M24 7/8"		M24 7/8"		M24 7/8"		M27 1"		M27 1"	
7"								M20 3/4"		M20 3/4"		M24 7/8"		M24 7/8"		M24 7/8"		M27 1"		M27 1"	
8"								M20 3/4"		M20 3/4"		M24 7/8"		M24 7/8"		M24 7/8"		M27 1"		M27 1"	
8"								M20 3/4"		M20 3/4"		M24 7/8"		M24 7/8"		M24 7/8"		M27 1"		M27 1"	
9"								M20 3/4"		M20 3/4"		M24 7/8"		M24 7/8"		M24 7/8"		M27 1"		M27 1"	
10"								M20 3/4"		M20 3/4"		M24 7/8"		M24 7/8"		M24 7/8"		M27 1"		M27 1"	
11"								M20 3/4"		M20 3/4"		M24 7/8"		M24 7/8"		M24 7/8"		M27 1"		M27 1"	
12"								M24 7/8"		M24 7/8"		M27 1"		M27 1"		M27 1"		M30 1 1/8"		M30 1 1/8"	
13"								M24 7/8"		M24 7/8"		M27 1"		M27 1"		M27 1"		M30 1 1/8"		M30 1 1/8"	
14"								M24 7/8"		M24 7/8"		M27 1"		M27 1"		M27 1"		M30 1 1/8"		M30 1 1/8"	
15"								M24 7/8"		M24 7/8"		M27 1"		M27 1"		M27 1"		M30 1 1/8"		M30 1 1/8"	
16"								M24 7/8"		M24 7/8"		M27 1"		M27 1"		M27 1"		M30 1 1/8"		M30 1 1/8"	
17"								M24 7/8"		M24 7/8"		M27 1"		M27 1"		M27 1"		M30 1 1/8"		M30 1 1/8"	
18"								M24 7/8"		M24 7/8"		M27 1"		M27 1"		M27 1"		M30 1 1/8"		M30 1 1/8"	
19"								M24 7/8"		M24 7/8"		M27 1"		M27 1"		M27 1"		M30 1 1/8"		M30 1 1/8"	
20"								M24 7/8"		M24 7/8"		M27 1"		M27 1"		M27 1"		M30 1 1/8"		M30 1 1/8"	
21"								M24 7/8"		M24 7/8"		M27 1"		M27 1"		M27 1"		M30 1 1/8"		M30 1 1/8"	
22"								M27 1"		M27 1"		M30 1 1/8"		M30 1 1/8"		M30 1 1/8"		M39 1 1/2"		M39 1 1/2"	
23"								M27 1"		M27 1"		M30 1 1/8"		M30 1 1/8"		M30 1 1/8"		M39 1 1/2"		M39 1 1/2"	
24"								M27 1"		M27 1"		M30 1 1/8"		M30 1 1/8"		M30 1 1/8"		M39 1 1/2"		M39 1 1/2"	
26"								no flange		no flange		M33 1 1/4"		M33 1 1/4"		M33 1 1/4"		M45 1 3/4"		M45 1 3/4"	
27"								M30 1 1/8"		M30 1 1/8"		M33 1 1/4"		M33 1 1/4"		M33 1 1/4"		M45 1 3/4"		M45 1 3/4"	
29"								M30 1 1/8"		M30 1 1/8"		M33 1 1/4"		M33 1 1/4"		M33 1 1/4"		M45 1 3/4"		M45 1 3/4"	
30"								M33 1 1/4"		M33 1 1/4"		M39 1 1/2"		M39 1 1/2"		M39 1 1/2"		M52 2"		M52 2"	
33"								M39 1 1/2"		M39 1 1/2"		M45 1 3/8"		M45 1 3/8"		M45 1 3/8"		M52 2"		M52 2"	
35"								M39 1 1/2"		M39 1 1/2"		M45 1 3/8"		M45 1 3/8"		M45 1 3/8"		M52 2"		M52 2"	
36"								M39 1 1/2"		M39 1 1/2"		M45 1 3/8"		M45 1 3/8"		M45 1 3/8"		M52 2"		M52 2"	
39"								M39 1 1/2"		M39 1 1/2"		M45 1 3/8"		M45 1 3/8"		M45 1 3/8"		M52 2"		M52 2"	
42"								M39 1 1/2"		M39 1 1/2"		M45 1 3/8"		M45 1 3/8"		M45 1 3/8"		M52 2"		M52 2"	
45"								M39 1 1/2"		M39 1 1/2"		M45 1 3/8"		M45 1 3/8"		M45 1 3/8"		M52 2"		M52 2"	
48"								M39 1 1/2"		M39 1 1/2"		M45 1 3/8"		M45 1 3/8"		M45 1 3/8"		M52 2"		M52 2"	
54"								M64 2 1/2"		M64 2 1/2"		M90 3 1/2"		M90 3 1/2"		M90 3 1/2"		M99 1 1/2"		M99 1 1/2"	
60"								M90 3 1/2"		M90 3 1/2"		M118 4 1/2"		M118 4 1/2"		M118 4 1/2"		M139 1 1/2"		M139 1 1/2"	
66"								M90 3 1/2"		M90 3 1/2"		M118 4 1/2"		M118 4 1/2"		M118 4 1/2"		M139 1 1/2"		M139 1 1/2"	
72"								M90 3 1/2"		M90 3 1/2"		M118 4 1/2"		M118 4 1/2"		M118 4 1/2"		M139 1 1/2"		M139 1 1/2"	
78"								M90 3 1/2"		M90 3 1/2"		M118 4 1/2"		M118 4 1/2"		M118 4 1/2"		M139 1 1/2"		M139 1 1/2"	
84"								M90 3 1/2"		M90 3 1/2"		M118 4 1/2"		M118 4 1/2"		M118 4 1/2"		M139 1 1/2"		M139 1 1/2"	
96"								M90 3 1/2"		M90 3 1/2"		M118 4 1/2"		M118 4 1/2"		M118 4 1/2"		M139 1 1/2"		M139 1 1/2"	
108"								M90 3 1/2"		M90 3 1/2"		M118 4 1/2"		M118 4 1/2"		M118 4 1/2"		M139 1 1/2"		M139 1 1/2"	
120"								M90 3 1/2"		M90 3 1/2"		M118 4 1/2"		M118 4 1/2"		M118 4 1/2"		M139 1 1/2"		M139 1 1/2"	