



SW9TM, SW14.5TI, SW15TE

FLANGE SPREADING WEDGES

Operator Instruction Manual



EQUALIZERTM
INTERNATIONAL

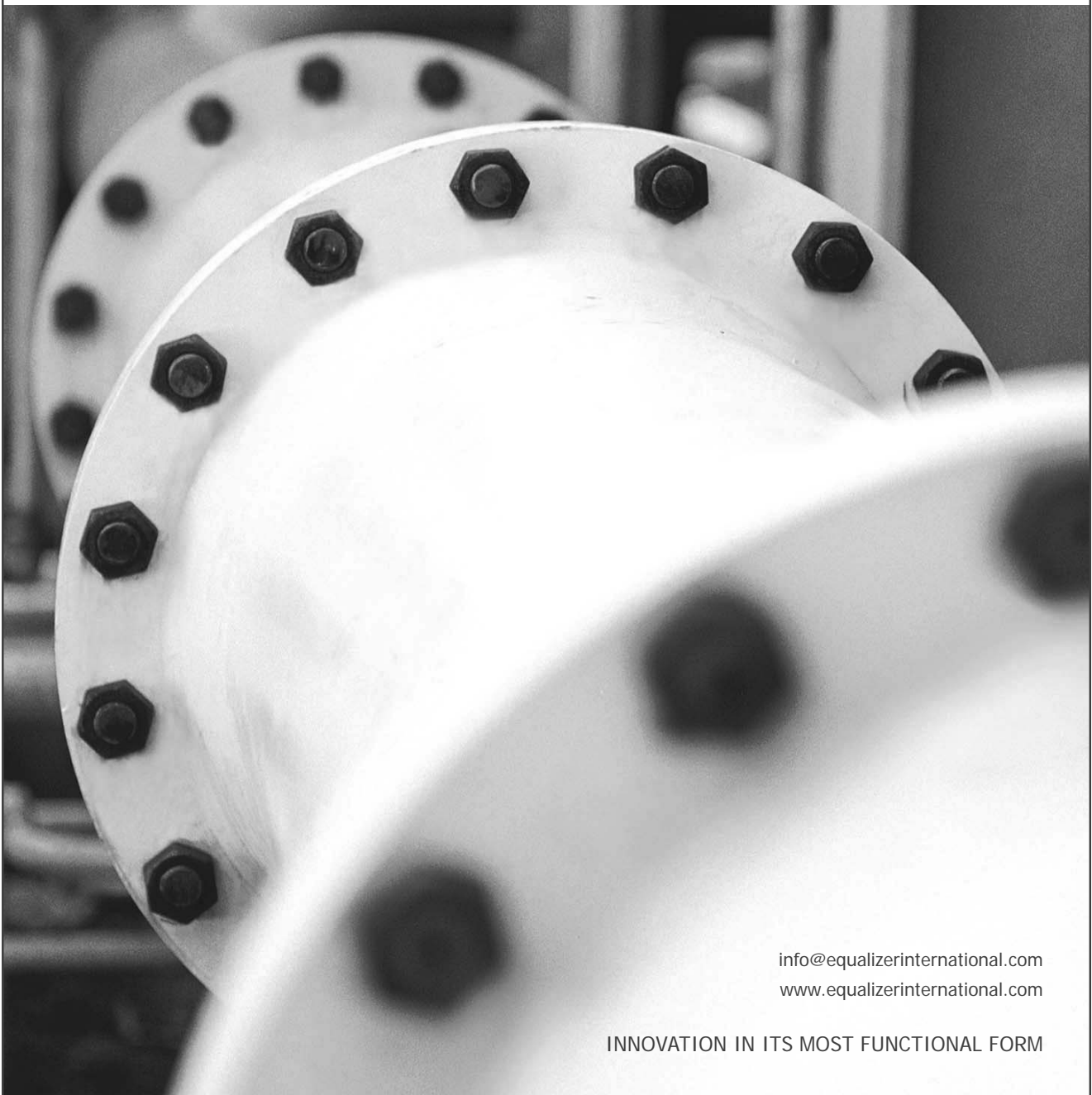

info@equalizerinternational.com
www.equalizerinternational.com

INNOVATION IN ITS MOST FUNCTIONAL FORM



INDEX

SECTION	CONTENTS	PAGE NO.
1	INTRODUCTION	1
2	SAFETY INFORMATION	2-3
3	TECHNICAL DATA	4
4	HOW THE FLANGE SPREADING WEDGES WORK	4
5	EXAMINATION, MAINTENANCE AND STORAGE	5
6	SW9TM MECHANICAL FLANGE SPREADING WEDGE	6-11
	6.1 KIT COMPONENTS	6
	6.2 INSTALLATION AND OPERATION	7-9
	6.3 PARTS LIST	10
	6.4 WEIGHTS AND DIMENSIONS	10-11
7	SW14.5TI INTEGRAL HYDRAULIC FLANGE SPREADING WEDGE	12-18
	7.1 KIT COMPONENTS	12
	7.2 INSTALLATION AND OPERATION	13-14
	7.3 PARTS LISTS	15-17
	7.4 WEIGHTS AND DIMENSIONS	17
	7.5 TROUBLESHOOTING	19
8	SW15TE HYDRAULIC FLANGE SPREADING WEDGE	20-30
	8.1 KIT COMPONENTS / KIT OPTIONS	20
	8.2 INSTALLATION AND OPERATION	21-24
	8.3 PARTS LISTS	25-27
	8.4 WEIGHTS AND DIMENSIONS	28-29
	8.5 TROUBLESHOOTING	30
9	STEPPED BLOCK ACCESSORY	31-32
	9.1 INSTALLATION AND OPERATION	31
	9.2 KIT COMPONENTS	32
	9.3 WEIGHTS AND DIMENSIONS	32

1. INTRODUCTION

The Equalizer SW9TM, SW14.5TI and SW15TE are aids for use in normal maintenance and installation procedures, and allow the spreading of flanges with an access gap of 6 mm (0.24") or greater. For example, they may be used to assist in the replacement of ring and other type joints. The use of these instructions will promote safe use, and maximize the service life of the tools. It is recommended that the operator read the relevant sections of this instruction manual for the particular flange spreading wedge to be used.

IM-FSW-REV21-A4
04.06.14



2. SAFETY INFORMATION

The operator MUST read this manual prior to using the tools.

Failure to comply with the following cautions and warnings could cause equipment damage and personal injury; read the manual fully!

Read all the following instructions, warnings and cautions carefully. Follow all safety precautions to avoid personal injury or property damage during system operation.

Equalizer International Ltd cannot be responsible for damage or injury resulting from unsafe product use, lack of maintenance or incorrect product and/or system operation. Contact Equalizer International Ltd when in doubt as to the safety precautions and applications. To protect your warranty, use only good quality hydraulic oil of the grade 15cSt.

Only people competent in the use of mechanical and hydraulic equipment should use these tools.

In all installations the site safety requirements must be adhered to. ALSO the safety of the operator, and when present, any assisting personnel, is of paramount importance along with the safety of others including, when present, the general public.

These instructions are only to cover the safe operation of THE EQUALIZER SW9TM, SW14.5TI AND SW15TE FLANGE SPREADING WEDGES, during normal maintenance/installation operations. All other safety aspects must be controlled by the operation supervisor.



A **CAUTION** is used to indicate correct operating or maintenance procedures and practices to prevent damage to, or destruction of equipment or other property.

A **WARNING** indicates a potential danger that requires correct procedures or practices to avoid personal injury.

A **DANGER** is only used when your action or lack of action may cause serious injury or even death.



IMPORTANT: Operator must be competent in the use of hydraulic equipment. The operator must have read and understood all instructions, safety issues, cautions and warnings before starting to operate the Equalizer equipment.



WARNING: To avoid personal injury and possible equipment damage, make sure all hydraulic components are rated to a safe working pressure of 700 bar (10,000 psi)



WARNING: Do not overload equipment. Overloading causes equipment failure and possible personal injury.

The risk of overloading can be avoided by using the Equalizer Hand Pump, which has its safety valve set to 700 bar by the factory. If alternative pumps are used, ensure they are rated at a safe working pressure of 700 bar (10,000 psi).



CAUTION: Make sure that all system components are protected from external sources of damage, such as excessive heat, flame, moving machine parts, sharp edges and corrosive chemicals.



CAUTION: Avoid sharp bends and kinks that will cause severe back-up pressure in hoses. Bends and kinks lead to premature hose failure. Do not drop heavy objects onto hoses. A sharp impact may cause internal damage to hose wire strands; applying pressure to a damaged hose may cause it to rupture. Do not place heavy weights on the hoses, or allow vehicles to roll over the hoses; crush damage will lead to premature hose failure.



WARNING: Immediately replace worn or damaged parts with genuine Equalizer parts. Equalizer parts are designed to fit properly and withstand rated loads. For repair or maintenance service contact your Equalizer distributor or service centre.



DANGER: To avoid personal injury keep hands and feet away from the tool and workpiece during operation.



WARNING: Always wear suitable clothing and Personal Protective Equipment (PPE).



DANGER: Do not handle pressurised hoses. Escaping oil under pressure can penetrate the skin, causing serious injury. If oil is injected under the skin, seek medical attention immediately.



WARNING: Never pressurize unconnected couplers. Only use hydraulic equipment in a connected system.



IMPORTANT: Do not lift hydraulic equipment by the hoses or couplers. Use the carrying handle or other means of safe transport.



CAUTION: Do not operate the equipment without lubricating all moving parts as in section 5. Use only high pressure molybdenum disulphide grease.



3. TECHNICAL DATA

	Spreading Force
SW9TM	9.4 T (94 kN) from 150 ft/lbs (203 N/m) of torque
SW14.5TI	14.5 T (145 kN) from 10,000 psi (700 bar) of hydraulic pressure
SW15TE	15.5 T (155 kN) from 10,000 psi (700 bar) of hydraulic pressure

4. HOW THE FLANGE SPREADING WEDGES WORK

1. The flange spreading wedge is placed between the flanges to be spread with the full step area fully inserted as far as the heel of the chosen step.

NB. When spreading a flange joint, it is recommended to use two wedges set 180 degrees apart on the joint. This will ensure that the flange joint can be opened evenly.

2. The flange is spread using either mechanical (SW9TM) or hydraulic power (SW14.5TI & SW15TE).

3. Once the joint has been opened to the desired distance, the safety blocks are inserted into the flange joint and the pressure released gradually back onto them.

4. The wedges can then be re-inserted using the next step and the flange joint can be opened further.

5. Repeat this procedure until the flange joint has been opened wide enough to carry out the remedial work (e.g. gasket change-out).



5. EXAMINATION, MAINTENANCE AND STORAGE

- On return from each job and before allocation against subsequent work the completeness of the Equalizer SW9TM, SW14.5TI or SW15TE kit must be established and items examined to ensure that they are serviceable.
- Any missing or damaged items are to be replaced as soon as possible and prior to the tool being used again.
- Store the SW9TM, SW14.5TI or SW15TE in a cool dry place and ensure all machined surfaces are greased
- Grease all moving parts prior to use:

Greasing the wedge:

- Remove the grease nipple from the handle of the tool

Screw the grease nipple into the jaw, attach the grease gun and squeeze grease into the wedge

OR

- Connect the hose to the wedge and advance the wedge forward, smear grease onto the surfaces of the wedge

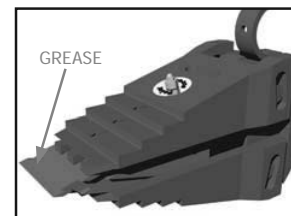
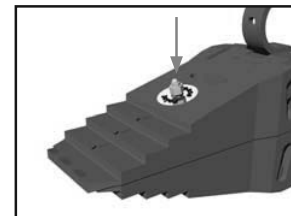
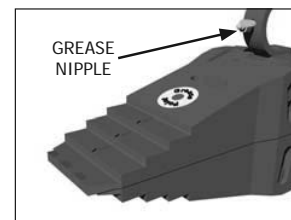

Greasing the slide pins:

- Simply smear some grease into the slots.

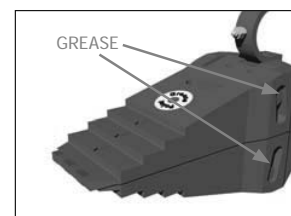



6. SW9TM MECHANICAL FLANGE SPREADING WEDGE

6.1 KIT COMPONENTS

- 1 x SW9TM Wedgehead
- 1 x 150 ft/lbs (203 N/m) Torque Wrench with 22 mm Socket
- 1 x Safety Block
- 1 x Instruction Manual
- 1 x Cardboard Packaging

Product Code: SW90TMMIN





6.2 INSTALLATION AND OPERATION



Before attaching the tool ensure at least two flange bolts remain in place 180 degrees apart with nuts loosened sufficiently enough for flange work to be carried out. These bolts will reduce lateral flange movement during flange spreading.

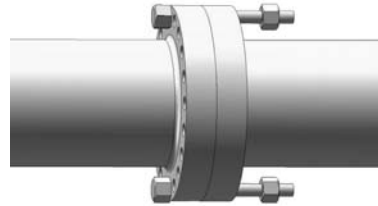

How to use the torque wrench

Balance the wrench in your left hand and unlock the knurled handle by turning the locking knob anti-clockwise. Set the torque amount by turning the knurled handle - see example 40-46 N/m

1. Turn the handle till 0 on fine scale reach 40 N/m on base scale
2. To set 46 turn handle till fine scale reach 6
3. Lock handle by turning the locking knob clockwise

Install the proper socket and attach to the tool. Pull handle till you feel and/or hear the wrench click. Setting of ft/lb scale is done in the same way as above.



Newton Scale (N/m)

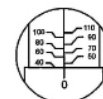

40 N/m

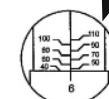

46 N/m
(1 on fine scale = 1 N/m)

Foot Pound (Ft.lb)

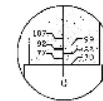

70 ft/lb

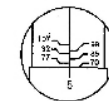

75 ft/lb
(1 on fine scale = 0.74 ft/lb)



Do not pull after the wrench clicks. Use special care at low torque settings. If the wrench has not been used for some time: operate it several times at low torque to allow internal lubricant to recoat. When not in use set to lowest torque setting. Don't turn handle below lowest torque setting. Your torque wrench is a precision measuring instrument and should be treated as such. Clean only by wiping, do not use any type of cleaner which may affect the special internal lubricant with which this wrench is packed at the factory.



1. Do not attempt to turn the grip while it is locked
2. Do not turn the grip more than one turn below the lowest scale reading or above the highest scale reading



1. Determine the flange joint access gap - a minimum access gap of 6 mm (0.24") is required.

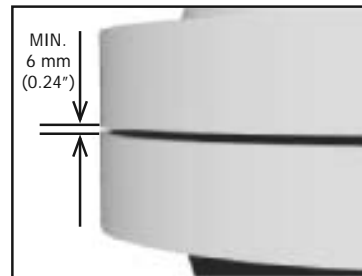

2. Insert the wedge into the joint until the heel of the step is in contact with the outer surface of the joint.

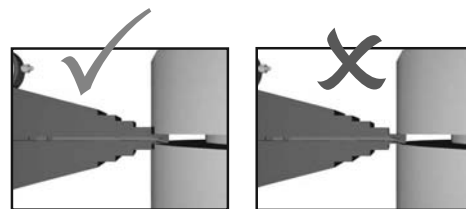

Ensure that the full step is used and that the jaw is positioned centrally.

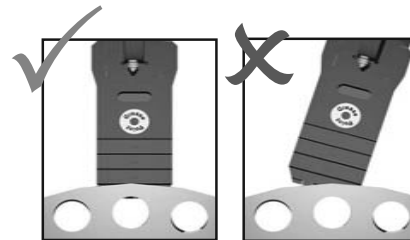

Inserting the wedge incorrectly may result in tool breakage and render the warranty void.

The rotating handle on the SW9™ allows ease of access to the joint and can be rotated out of the way of any obstructions present.





- 3.** It is strongly recommended that two SW9™ wedges be used on the flange joint positioned 180 degrees apart.

Turn each push rod in a clockwise direction using the torque wrench. Do this on each wedge in turn, ensuring the joint opens evenly. The torque wrench should be set at staged increases, ensuring both tools are applying similar forces e.g. 20 ft/lbs, 40 ft/lbs etc. until the maximum setting of 150 ft/lbs is reached.

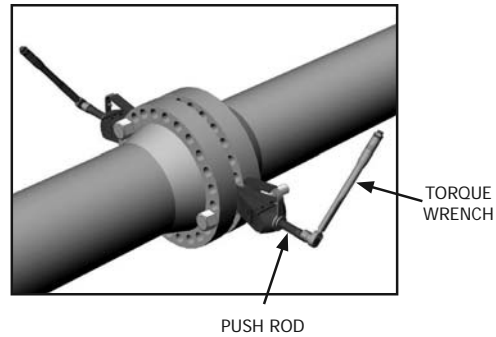

Max. torque wrench setting	N/m	203
	ft/lb	150
Max. spreading force	T	9
	kN	90

- 4.** When the joint has been opened to the desired spreading distance, or the maximum spreading distance on the current step is reached, the safety block should be inserted into the joint and the pressure released back onto it.

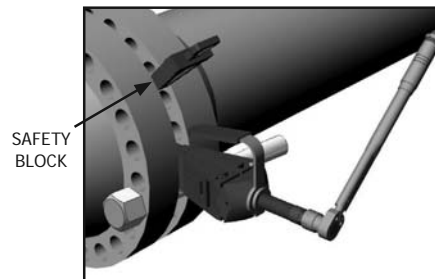

- 5.** The wedge can then be re-inserted on its next step and the joint opened further.

- 6.** Once the joint has been spread and all work completed, the wedges should be removed by reversing steps 3-5. Ensure the wedges are released evenly until completely closed.

Care should be taken not to drop any of the component parts when removing them from the flange joint. This action will prevent injuries to either the operator's lower limbs, or to passers-by.



6.3 PARTS LIST

SW9TM

ITEM NO.	PART NO	DESCRIPTION	QTY.
01	060101-01	WHITE PLASTIC CAP	01 each
02		SERIAL NO STICKER	01 each
03		PINCH POINT STICKER	02 each
04		GREASE POINT STICKER	02 each
05		BADGE LOGO	02 each
06		SWL STICKER	02 each
07	300101-01	WEDGE	01 each
08*		M5X6 SCKT SCREW	01 set of 4
09*		SLIDE PIN	01 set of 4
10	301102-01	MAIN BODY	01 each
11	301201-08	SPIRAL PIN	01 set of 8
12*		M6X12 GRUB SCREW	01 each
13*		M14 HALF NUT	01 each
14*		BEARING CARRIER	01 each
15	301901-01	M/F ADAPTOR	01 each
16	302001-01	HANDLE	01 each
17	302101-01	EXTERNAL CIRCLIP	01 each
18*		PUSH ROD	01 each
19	310601-01	M6 GREASE NIPPLE	01 each
20	312302-01	HANDLE SLEEVE	01 each
21*		THRUST WASHER	02 each
22*		THRUST RACE	01 each
23	300203-02	JAW (PAIR)	01 set of 2
24	320901-01	22 MM 1/2" SOCKET	01 each
25	634001-01	TORQUE WRENCH	01 each

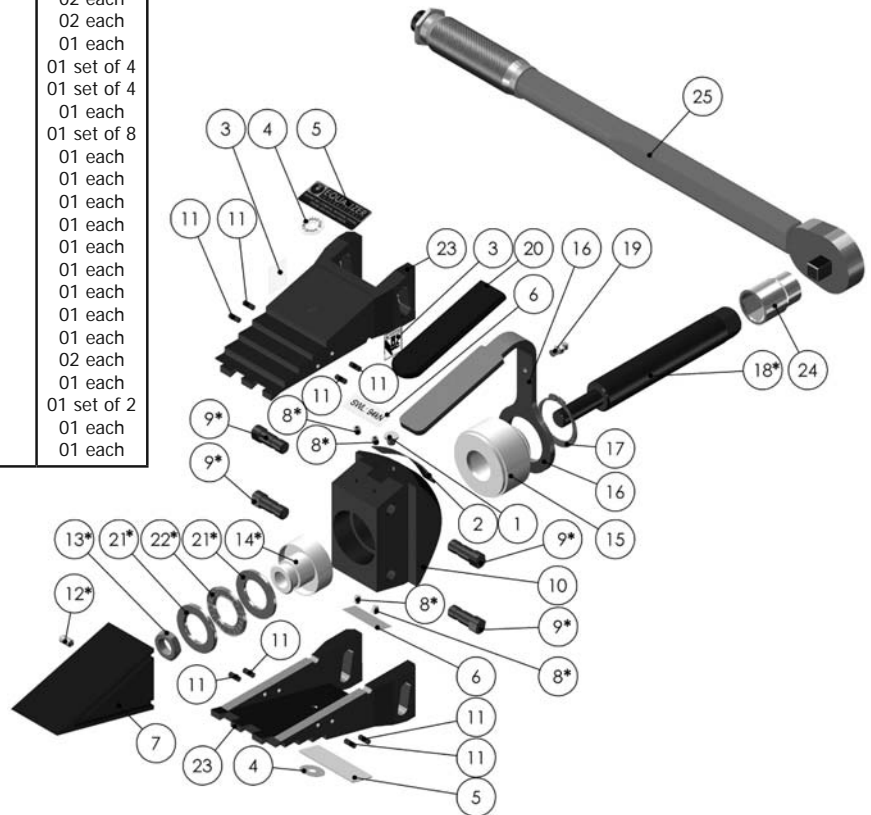

*Items 8, 9, 12, 13, 21 & 22 are supplied in Repair Kit Part No: 310501-01
*Items 14 & 18 are supplied in Repair Kit Part No: 310502-01

6.4 WEIGHTS AND DIMENSIONS

SW9TM Wedgehead

= 5.5 kg (12.13 lbs)

GROSS KIT WEIGHT

= 7.5 kg (16.53 lbs)

Packaging Dimensions: 190 x 180 x 320 mm (7.48" x 7.09" x 12.60")



MINIMUM EXTENSIONS

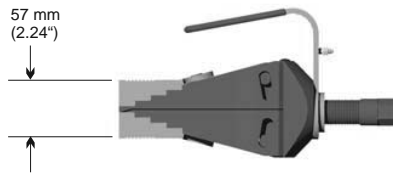
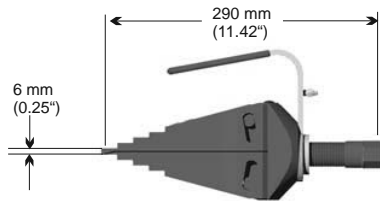

MAXIMUM EXTENSIONS

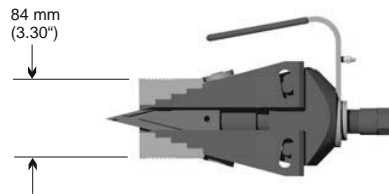
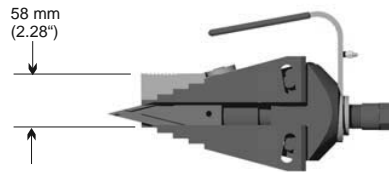
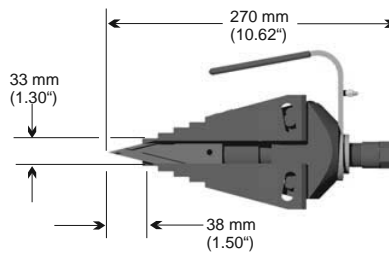

OVERALL DIMENSIONS

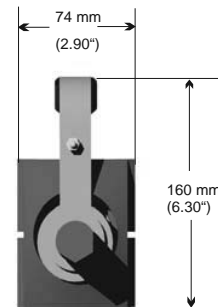
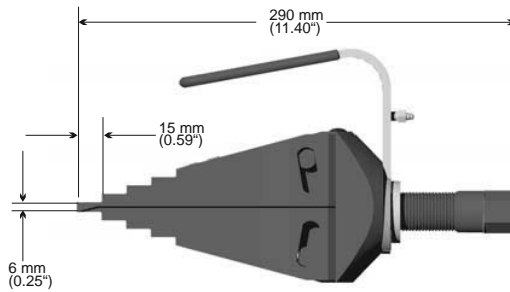

SAFETY BLOCK DIMENSIONS

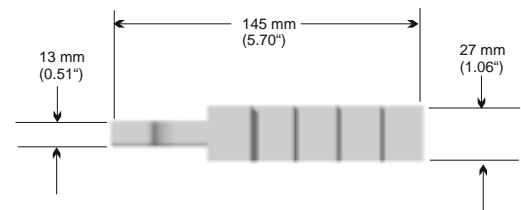
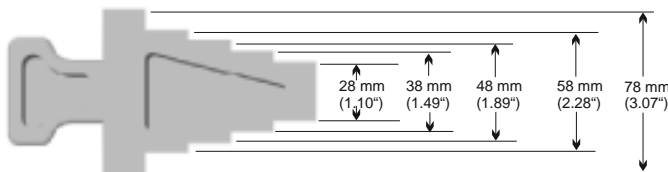



7. SW14.5TI INTEGRAL HYDRAULIC FLANGE SPREADING WEDGE

7.1 KIT COMPONENTS

- 1 x SW14.5TI Wedgehead
- 1 x 10,000 psi (700 bar) Integral Hydraulic Pump/Cylinder
- 1 x Safety Block
- 1 x Carry-Strap
- 1 x Instruction Manual
- 1 x Carry-Case



Product Code: SW14.5TISP

Also available with Stepped Blocks (Product Code: SW14.5TISPB)

Refer to Section 9 for details



7.2 INSTALLATION AND OPERATION

1. Determine the flange joint access gap - a minimum access gap of 6 mm (0.24") is required.

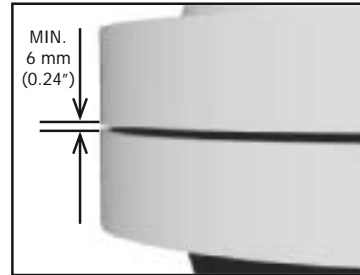

2. Before installing the wedge, ensure that it is fully retracted and tighten the return valve in a clockwise direction to the closed position.

Also ensure the air vent is not obstructed in any way as this will result in a vacuum within the system and the wedge will not advance.

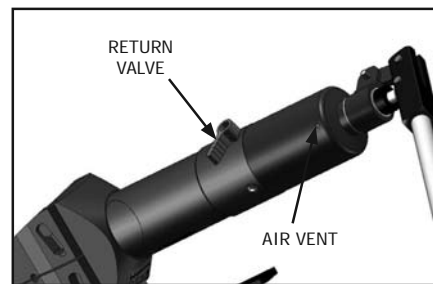

Before attaching the tool ensure at least two flange bolts remain in place 180 degrees apart with nuts removed. These bolts will reduce lateral flange movement during flange spreading.

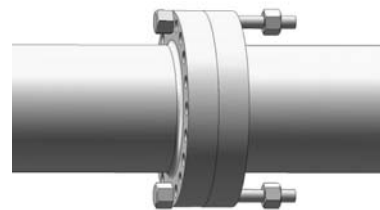

3. Insert the wedge into the joint until the heel of the step is in contact with the outer surface of the joint.

Ensure that the full step is used and that the jaw is positioned centrally.

Inserting the wedge incorrectly may result in tool breakage and render the warranty void.

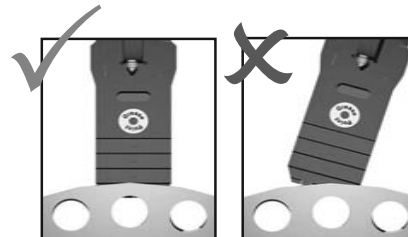
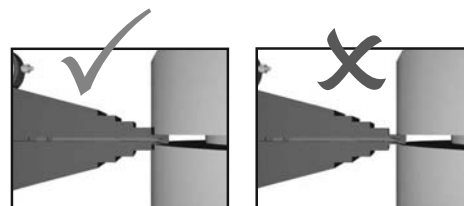



-
4. It is strongly recommended that two SW14.5TI wedges be used on the flange joint positioned 180 degrees apart.

Prime each pump individually ensuring that the flange joint opens evenly.

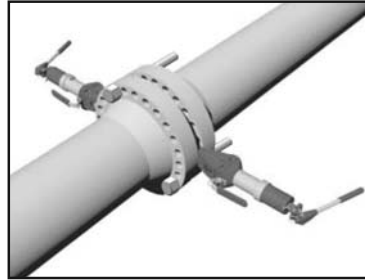

-
5. When the joint has been opened to the desired spreading distance, or the maximum spreading distance on the current step is reached, the safety block should be inserted into the joint and the pressure released back onto it.

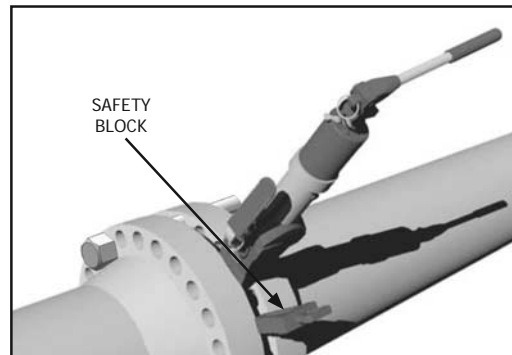

-
6. The wedge can then be re-inserted on its next step and the joint opened further.

-
7. Once the joint has been spread and all work completed, the wedges should be removed by reversing steps 4 - 6. Release the wedges by turning the return valve anti-clockwise. Ensure the wedges are released evenly until completely closed.

Care should be taken not to drop any of the component parts when removing them from the flange joint. This action will prevent injuries to either the operator's lower limbs, or to passers-by.



7.3 PARTS LISTS

SW14.5TI

*Items 9,10,12,13 & 18 supplied in Repair Kit Part No 310301-01

ITEM NO.	PART NO	DESCRIPTION	QTY.
01		SERIAL NO STICKER	01 each
02		QC SEALED STICKER	02 each
03		PINCH POINT STICKER	02 each
04		GREASE POINT STICKER	02 each
05		READ INSTR. STICKER	01 each
06		BADGE LOGO	02 each
07	300101-01	WEDGE	01 each
08	300301-01	PUSH PIN	01 each
09*		M5X6 SCKT SCREW	01 set of 4
10*		SLIDE PIN	01 set of 4
11	301102-01	MAIN BODY	01 each
12*		SPIRAL PIN	01 set of 8
13*		M6X12 GRUB SCREW	01 each
14	308201-01	HANDLE	01 each
15	310601-01	M6 GREASE NIPPLE	01 each
16	311601-01	SPLIT RING	01 set of 2
17	301230-01	HANDLE SLEEVE	01 each
18	300203-02	JAWS (PAIR)	01 set of 2
19*		5/16" SCREW	01 each
20	510701-01	INT. PUMP & CYLINDER	01 each
21	375010-01	SERVICE KIT A (Illustrated below)	1 kit
22	375015-01	SERVICCE KIT B (Illustrated below)	1 kit
23	375020-01	SERVICE KIT C (Illustrated below)	1 kit
	510700-01	SERVICE KIT D (Illustrated below)	1 kit
	375030-01	SERVICE KIT E (Illustrated below)	1 kit

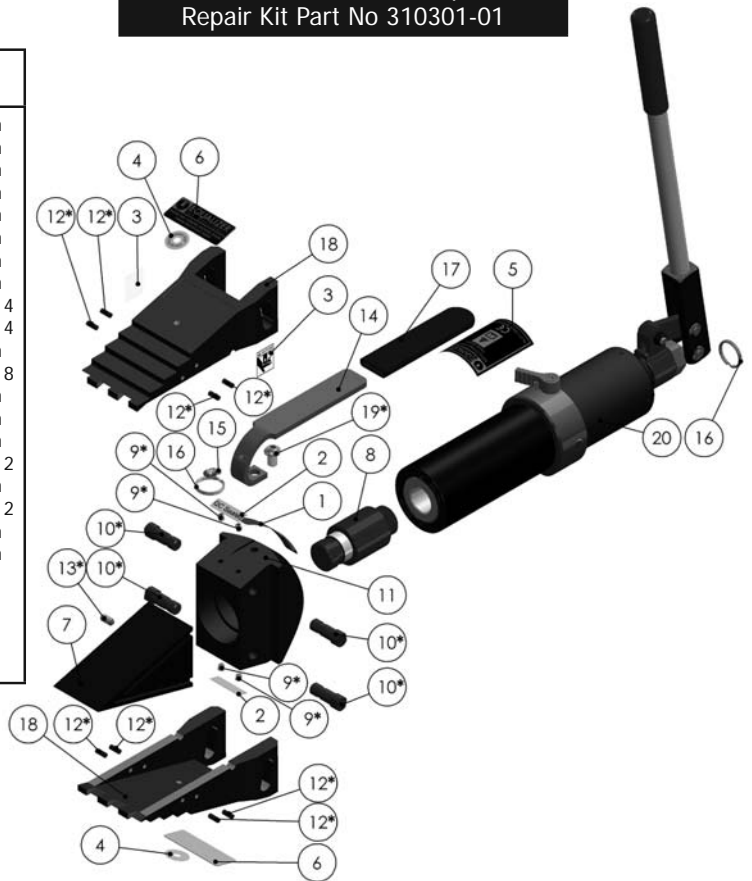

**INTEGRAL HYDRAULIC
PUMP/CYLINDER**
serial no: up to 7915

ITEM	PART NO	DESCRIPTION	QUANTITY
01	370101	PULLER BODY	01 ea
02	370201	PULLER PISTON ROD	01 ea
03	KIT B	BACK-UP RING	01 ea
04	KIT B	U-CUP SEAL	01 ea
05	KIT B	RETAINING RING	01 ea
06	370601	PIN	01 ea
07	370701	COMPRESS SPRING	01 ea
08	KIT B	ROD WIPER	01 ea
09	KIT A	OIL FILL SCREW	01 ea
10	KIT A	STEEL BALL	01 ea
11	KIT A	O-RING	02 ea
12	KIT A	RELIEF VALVE SCREW	01 ea
13	371301	RELIEF VALVE KNOB	01 ea
14	KIT A	FIXING SCREW	01 ea
15	KIT A	COPPER WASHER	01 ea
16	KIT B	SAFETY VALVE	01 ea
17	371701	PUMP PISTON HOUSING	01 ea
18	KIT A	O-RING	02 ea
19	KIT A	BACK-UP RING	01 ea
20	KIT A	RESERVOIR BLADDER	01 ea
21	KIT B	O-RING	01 ea
22	KIT B	O-RING	01 ea
23	372301	BLADDER HOUSING	01 ea
24	372401	PISTON HOUSING CAP	01 ea
25	372501	SWIVEL CLEVIS	01 ea
26	372601	RETAINING NUT	01 ea
27	KIT A	PUMP PISTON ROD	01 ea
28	372801	HANDLE CLEVIS	01 ea
29	372901	CLEVIS PIN	02 ea
30	373001	RETAINING RING	04 ea
31	373101	LINK CONNECTOR	01 ea
32	373201	CLEVIS SCREW	01 ea
33	373301	ANTI-LOOSEN NUT	01 ea
34	373401	SOLID HANDEL LEVER	01 ea
35	373501	RAM SLEEVE	01 ea
36	KIT B	SPRING END CAP	01 ea
37	KIT B	STEEL BALL	01 ea
38	KIT B	SPRING	01 ea
39	KIT A	OVERLOAD COVER SCREW	01 ea
40	KIT A	CAP	01 ea
41	KIT B	O-RING	01 ea

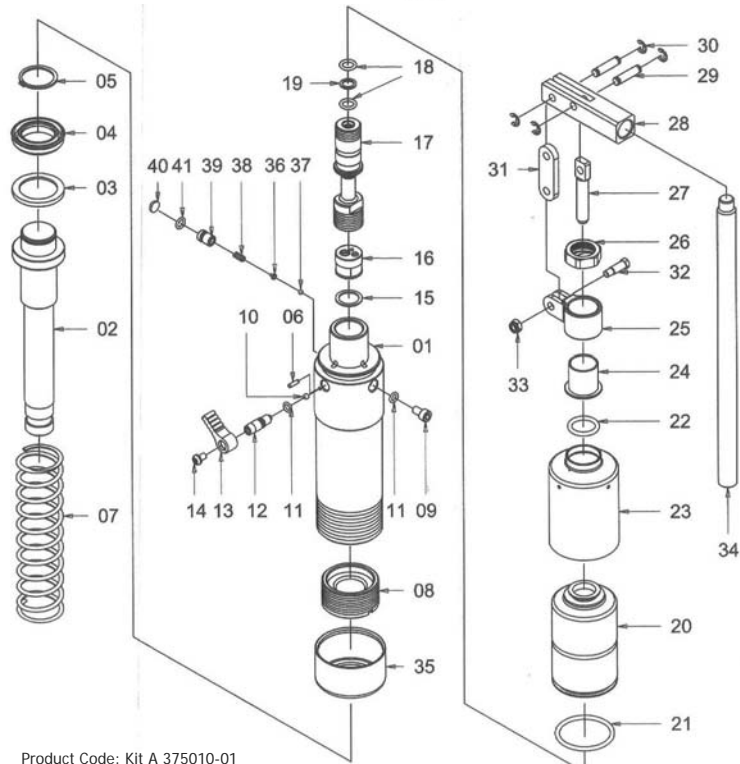

Product Code: Kit A 375010-01
Product Code: Kit B 375015-01



INTEGRAL HYDRAULIC PUMP/CYLINDER
serial no: 7915 to 11187

ITEM NO.	PART NO	DESCRIPTION	QTY.
01	370601-01	PIN	01
02	372301-01	BLADDER HOUSING	01
03	342401-01	PISTON HOUSING CAP	01
04	372501-01	SWIVEL CLEVIS	01
05	372601-01	RETAINING NUT	01
06	372901-01	CLEVIS PIN	02
07	373001-01	RETAINING RING	04
08	373101-01	LINK CONNECTOR	01
09	373201-01	CLEVIS SCREW	01
10	373301-01	ANTI-LOOSEN NUT	01
11	373401-01	HANDLE ROD	01
12	375101-01	CYLINDER BASE	01
13	375601-01	PISTON ROD	01
14	376301-01	PULLER BODY	01
15	376401-01	ROD WIPER	01
16	376901-01	PUMP PISTON HOUSING	01
17	377101-01	HANDLE CLEVIS	01
18	510713-01	HANDLE GRIP	01
19	375010-01	SERVICE KIT A	01
20		OIL FILL SCREW	01
21		STEEL BALL	01
22		O-RING	03
23		RELIEF VALVE SCREW	01
24		RELIEF VALVE KNOB	01
25		WASHER	01
26		O-RING	02
27		BACK UP RING	01
28		RESERVOIR BLADDER	01
29		O-RING	01
30		PUMP PISTON ROD	01
31		OVERLOAD COVER SCREW	01
32		CAP	01
33		O-RING	01
34		O-RING	01
35		FIXING SCREW	01
36	375020-01	SERVICE KIT C	01
37		STEEL BALL	02
38		SPRING	02
39		SCREW	01
40		BACK-UP RING	01
41		O-RING	01
42		PIN	01
43		GASKET SEAL	01
44		SPRING LOCK	01
45		CONE SEAT	01
46		CONE	01
47		LONG SEPARATOR SPRING	01
48	375030-01	SERVICE KIT E	01
49		O-RING	01
50		BACK-UP RING	01
51		SPLIT RING	01
52		SPRING	01
53		SPRING CLOCK	01
54		WIPER	01
55		SCREW	01

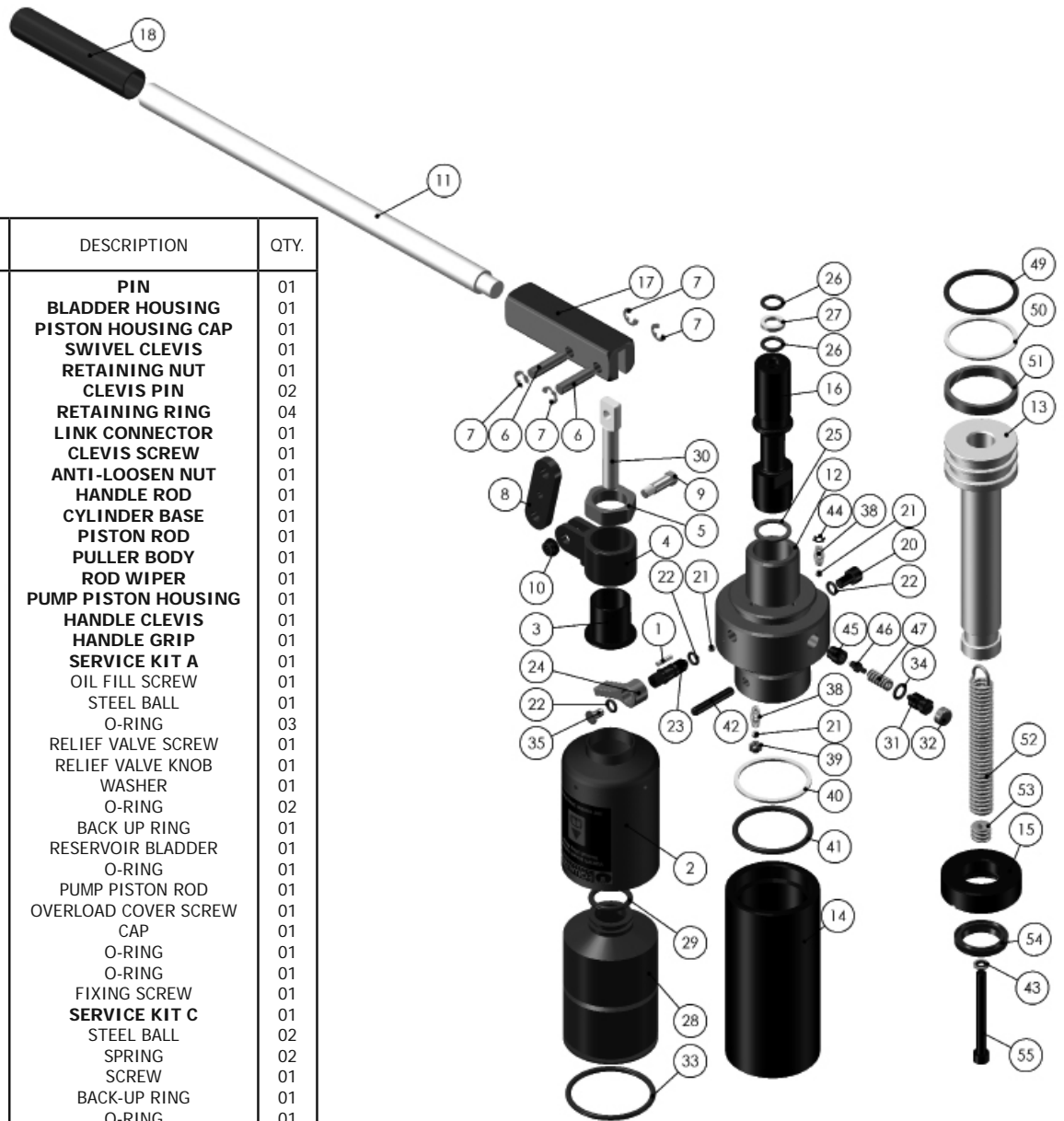



INTEGRAL HYDRAULIC PUMP/CYLINDER serial no: 11187 onwards

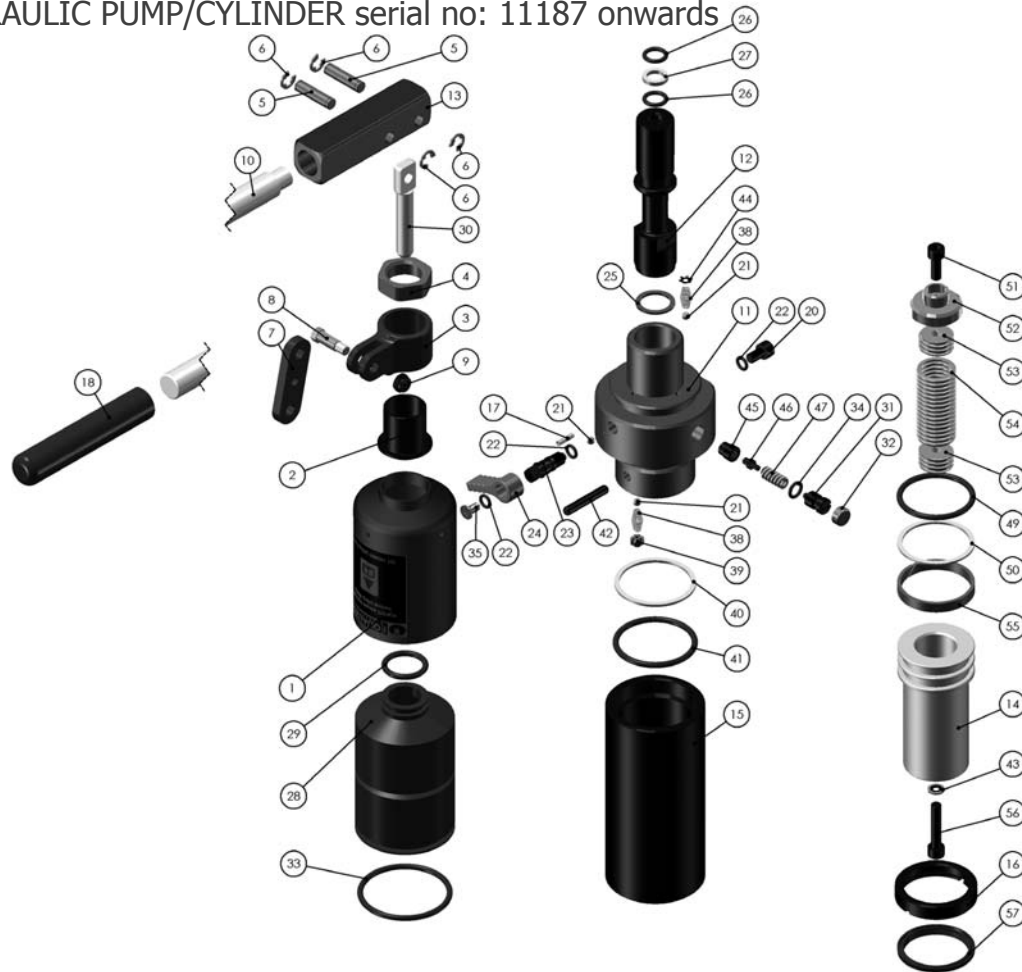

ITEM NO.	PART NO	DESCRIPTION	QTY.	ITEM NO.	PART NO	DESCRIPTION	QTY.	ITEM NO.	PART NO	DESCRIPTION	QTY.
01	372301-01	BLADDER HOUSING	01	19	375010-01	SERVICE KIT A	01	36	375020-01	SERVICE KIT C	01
02	342401-01	PISTON HOUSING CAP	01	20		OIL FILL SCREW	01	21		STEEL BALL	02
03	372501-01	SWIVEL CLEVIS	01	21		STEEL BALL	01	38		SPRING	02
04	372601-01	RETAINING NUT	01	22		O-RING	03	39		SCREW	01
05	372901-01	CLEVIS PIN	02	23		RELIEF VALVE SCREW	01	40		BACK-UP RING	01
06	373001-01	RETAINING RING	04	24		RELIEF VALVE KNOB	01	41		O-RING	01
07	373101-01	LINK CONNECTOR	01	25		WASHER	01	42		PIN	01
08	373201-01	CLEVIS SCREW	01	26		O-RING	02	43		GASKET SEAL	01
09	373301-01	ANTI-LOOSEN NUT	01	27		BACK UP RING	01	44		SPRING LOCK	01
10	373401-01	HANDLE ROD	01	28		RESERVOIR BLADDER	01	45		CONE SEAT	01
11	375101-01	CYLINDER BASE	01	29		O-RING	01	46		CONE	01
12	376901-01	PUMP PISTON HOUSING	01	30		PUMP PISTON ROD	01	47		LONG SEPARATOR SPRING	01
13	377101-01	HANDLE CLEVIS	01	31		OVERLOAD COVER SCREW	01	48	510700-01	SERVICE KIT D	01
14	510701-01	PISTON ROD	01	32		CAP	01	49		O-RING	01
15	510708-01	PULLER BODY	01	33		O-RING	01	50		BACK-UP RING	01
16	510709-01	FASTEN NUT	01	34		O-RING	01	51		SCREW	01
17	510712-01	ROLL PIN	01	35		FIXING SCREW	01	52		STOP COLLAR	01
18	510713-01	HANDLE GRIP	01					53		SPRING LOCK	01
								54		SPRING	01
								55		SPLIT RING	01
								56		SCREW	01
								57		WIPER	01

7.4 WEIGHTS AND DIMENSIONS

SW14.5TI Wedgehead with Integral Hydraulic Pump/Cylinder = 9.0 kg (19.8 lbs)

Carry-Case = 2.5 kg (5.5 lbs)

GROSS KIT WEIGHT = 14 kg (28.6 lbs)

Carry-Case Dimensions: 580 x 340 x 180 mm (22.8" x 13.4" x 7")



MINIMUM EXTENSIONS

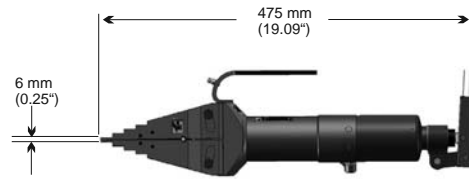

MAXIMUM EXTENSIONS

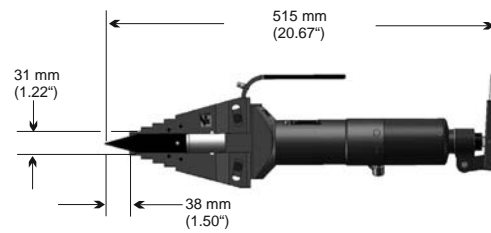

OVERALL DIMENSIONS

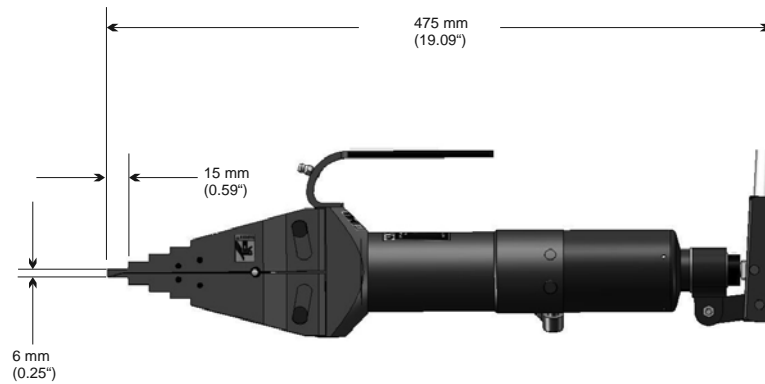

SAFETY BLOCK DIMENSIONS

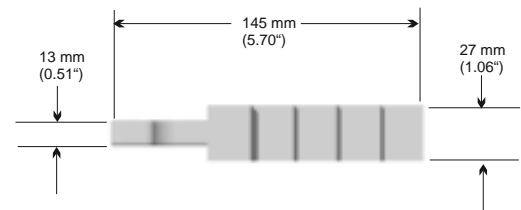
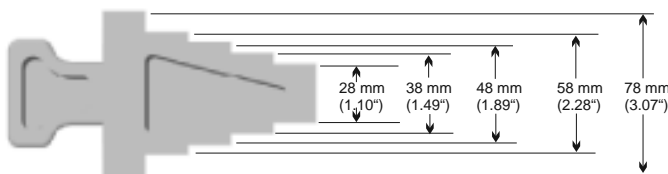



7.5 TROUBLESHOOTING

Problem: Wedge advances 50% and then stops functioning

- | | |
|--|--|
| ↪ A sticker has been placed over the air vent | ↪ Remove sticker |
| ↪ The operator is covering the air vent with his finger while operating the pump | ↪ One hand should be on the handle of the tool while the other hand operates the pump handle |
| ↪ The air vent has become blocked with dirt | ↪ Carefully unblock the air vent using a small blunt object |

Problem: No wedge movement

- | | |
|---|---|
| ↪ Air lock within system | ↪ Open release valve and prime pump to circulate oil around the system |
| ↪ Insufficient oil | ↪ Refill with clean oil and bleed system |
| ↪ Release valve open | ↪ Close release valve |
| ↪ Air accumulates around pump inlet when used upside down | ↪ Bleed out air from reservoir. Look for any oil leaks on reservoir which may indicate a perished bladder. Refer to SW14.5TI Repair Manual or an approved Equalizer distributor for further instructions. |
| ↪ Inlet check or intermediate valve ball stuck | ↪ Dismantle check valve, free and clean balls. Refer to SW14.5TI Repair Manual or an approved Equalizer distributor for further instructions. |

Problem: Wedge moves but under load feels as if it is not reaching full pressure

- | | |
|---|---|
| ↪ Intermediate valve not seating / relief valve leaking | ↪ Check ball for dirt then re-seat using a hammer and punch. Refer to SW14.5TI Repair Manual or an approved Equalizer distributor for further instructions. |
|---|---|

Problem: Pressure leaks away, handle rises of its own accord

- | | |
|------------------------------|---|
| ↪ Outlet check valve leaking | ↪ Check ball for dirt then re-seat using a hammer and punch. Refer to SW14.5TI Repair Manual or an approved Equalizer distributor for further instructions. |
|------------------------------|---|

Problem: Pressure leaks away, handle remains static

- | | |
|----------------------------------|--|
| ↪ Release valve leaking | ↪ Release lever may not be tight enough. Refer to SW14.5TI Repair Manual or an approved Equalizer distributor for further instructions. |
| ↪ Piston seal leaking | ↪ Look for oil leaking from cylinder bearing. Refer to SW14.5TI Repair Manual or an approved Equalizer distributor for further instructions. |
| ↪ Leaks on cylinder or pump body | ↪ Check blanking plugs for leaks, tighten. Refer to SW14.5TI Repair Manual or an approved Equalizer distributor for further instructions. |

Problem: Spongy action

- | | |
|-----------------|--|
| ↪ Air in system | ↪ Bleed system. Refer to SW14.5TI Repair Manual or an approved Equalizer distributor for further instructions. |
|-----------------|--|



8. SW15TE HYDRAULIC FLANGE SPREADING WEDGE

8.1 KIT COMPONENTS / KIT OPTIONS

MINI KIT

- 1 x SW15TE Wedgehead
- 1 x 10,000 psi (700 bar) Hydraulic Cylinder
- 1 x Safety Block
- 1 x Instruction Manual
- 1 x Cardboard Packaging

Product Code: SW15TEMIN



STANDARD KIT

- 1 x SW15TE Wedgehead
- 1 x 10,000 psi (700 bar) Hydraulic Hose, 2 m (78.75")
- 1 x 10,000 psi (700 bar) Hydraulic Cylinder
- 1 x 10,000 psi (700 bar) HP350S
- Sealed Hand Pump with Gauge
- 1 x Safety Block
- 1 x Instruction Manual
- 1 x Carry-Case

Product Code: SW15TESP

Also available with Stepped Blocks (Product Code: SW15TESPB)
Refer to Section 9 for details



MAXI KIT

- 2 x SW15TE Wedgeheads
- 2 x 10,000 psi (700 bar) Hydraulic Hoses, 2 m (78.75") each
- 2 x 10,000 psi (700 bar) Hydraulic Cylinders
- 1 x 10,000 psi (700 bar) HP350D
- Sealed Hand Pump with Gauges
- 2 x Safety Blocks
- 1 x Instruction Manual
- 1 x Carry-Case

Product Code: SW15TEMAXSP

Also available with Stepped Blocks (Product Code: SW15TEMAXSPB)
Refer to Section 9 for details





8.2 INSTALLATION AND OPERATION

MINI AND STANDARD KIT

The operation procedure is exactly the same for both the SW15TE Mini and Standard Kits. The SW15TE Mini Kit does not contain either a 10,000 psi (700 bar) hydraulic hand pump or a 10,000 psi (700 bar) hydraulic hose. These items will come from the user's inventory.

1. Determine the flange joint access gap - a minimum access gap of 6 mm (0.24") is required.

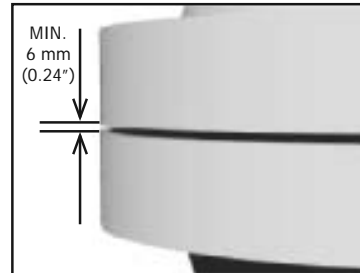

2. Before installing the wedge, the hose should be connected to the respective couplings on the pump and cylinder.

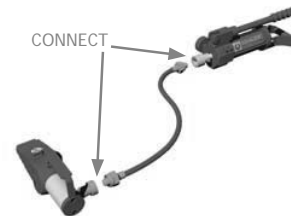

Before attaching the tool ensure at least two flange bolts remain in place 180 degrees apart with nuts removed. These bolts will reduce lateral flange movement during flange spreading.

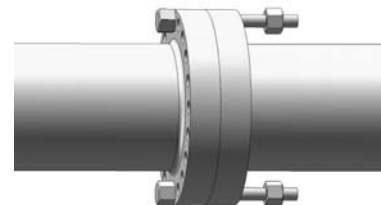

3. Insert the wedge into the joint until the heel of the step is in contact with the outer surface of the joint.

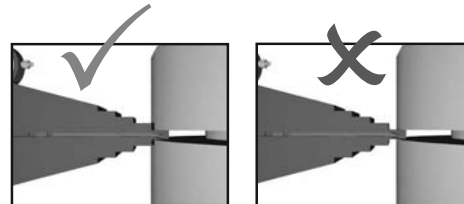

Ensure that the full step is used and that the jaw is positioned centrally.

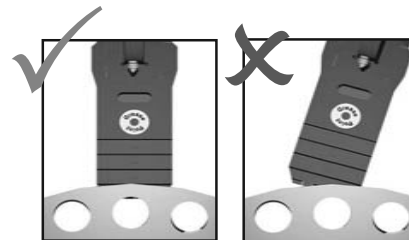

Inserting the wedge incorrectly may result in tool breakage and render the warranty void.



-
4. It is strongly recommended that two SW15TE wedges be used on the flange joint positioned 180 degrees apart.

Prime each pump individually ensuring that the flange joint opens evenly.

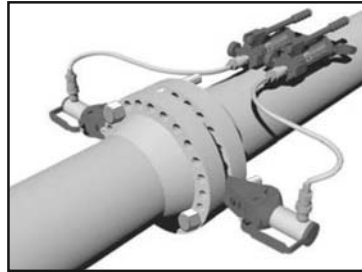

-
5. When the joint has been opened to the desired spreading distance, or the maximum spreading distance on the current step is reached, the safety block should be inserted into the joint and the pressure released back onto it.

SAFETY
BLOCK

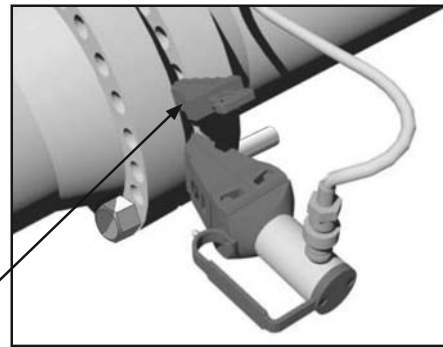

-
6. The wedge can then be re-inserted on its next step and the joint opened further.

-
7. Once the joint has been spread and all work completed, the wedges should be removed by reversing steps 4 - 6. Release the wedges by turning the release valve on the pump anti-clockwise. Ensure the wedges are released evenly until completely closed.

Care should be taken not to drop any of the component parts when removing them from the flange joint. This action will prevent injuries to either the operator's lower limbs, or to passers-by.



MAXI KIT

1. Determine the flange joint access gap - a minimum access gap of 6 mm (0.24") is required.

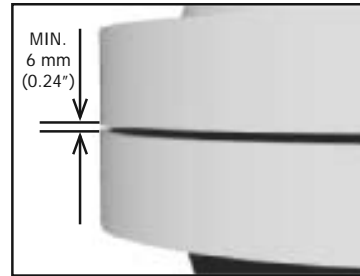

2. Before installing the wedge, the hoses should be connected to the respective couplings on the pump and cylinders.



Before attaching the tool ensure at least two flange bolts remain in place 180 degrees apart with nuts removed. These bolts will reduce lateral flange movement during flange spreading.

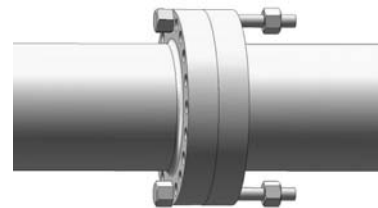

3. Insert the wedge into the joint until the heel of the step is in contact with the outer surface of the joint.

Ensure that the full step is used and that the jaw is positioned centrally.

Inserting the wedge incorrectly may result in tool breakage and render the warranty void.

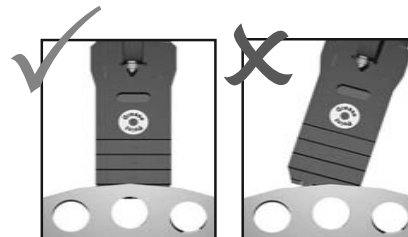
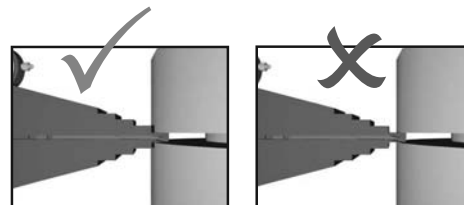



-
4. Position the wedges 180 degrees apart on the flange joint.

Open both upper valves on the pump and close the release valve (located on the side of the pump).

Advance the wedges by priming the pump.

If one side of the joint seems to be spreading more than the other, close the upper valve on the pump which corresponds to that side and carry on priming until the opposite side catches up.

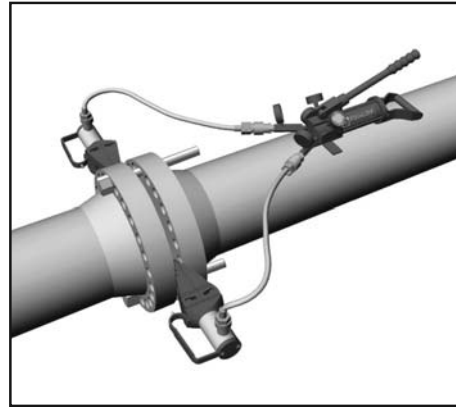

The procedure can now be completed by following steps 5 - 7 of the Mini and Standard Kit installation procedure (see previous section)



8.3 PARTS LISTS

SW15TE

ITEM NO.	PART NO	DESCRIPTION	QTY.
01		SERIAL NO STICKER	01 each
02		QC SEALED STICKER	02 each
03		PINCH POINT STICKER	02 each
04		GREASE POINT STICKER	02 each
05		CYLINDER STICKER	01 each
06		BADGE LOGO	02 each
07	300101-01	WEDGE	01 each
08	300301-01	PUSH PIN	01 each
09*		M5X6 SCKT SCREW	01 set of 4
10*		SLIDE PIN	01 set of 4
11	300701-01	HANDLE	01 each
12*		BASE SCREWS FOR HANDLE	01 set of 2
13	301003-01	HYDRAULIC CYLINDER	01 each
14	301102-01	MAIN BODY	01 each
15*		SPIRAL PIN	01 set of 8
16*		M6X12 GRUB SCREW	01 each
17	310601-01	M6 GREASE NIPPLE	01 each
18	300203-02	JAWS (PAIR)	01 set of 2
19*		RETAINING SCREW FOR HANDLE	01 each
20	301403-01	CYLINDER REPAIR KIT (Illustrated below)	01 kit

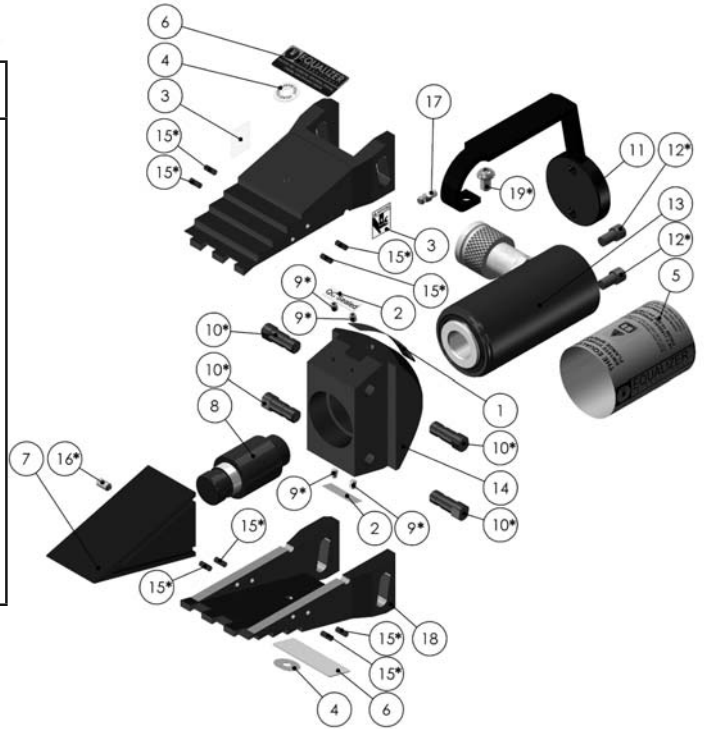

*Items 9,10,12,15,16 & 19 supplied in
Repair Kit Part No 310301-01

NOTE:
IF THE CYLINDER WAS MADE
BEFORE FEBRUARY 2008
THE PISTON PART NO 510701-01
WILL BE REQUIRED

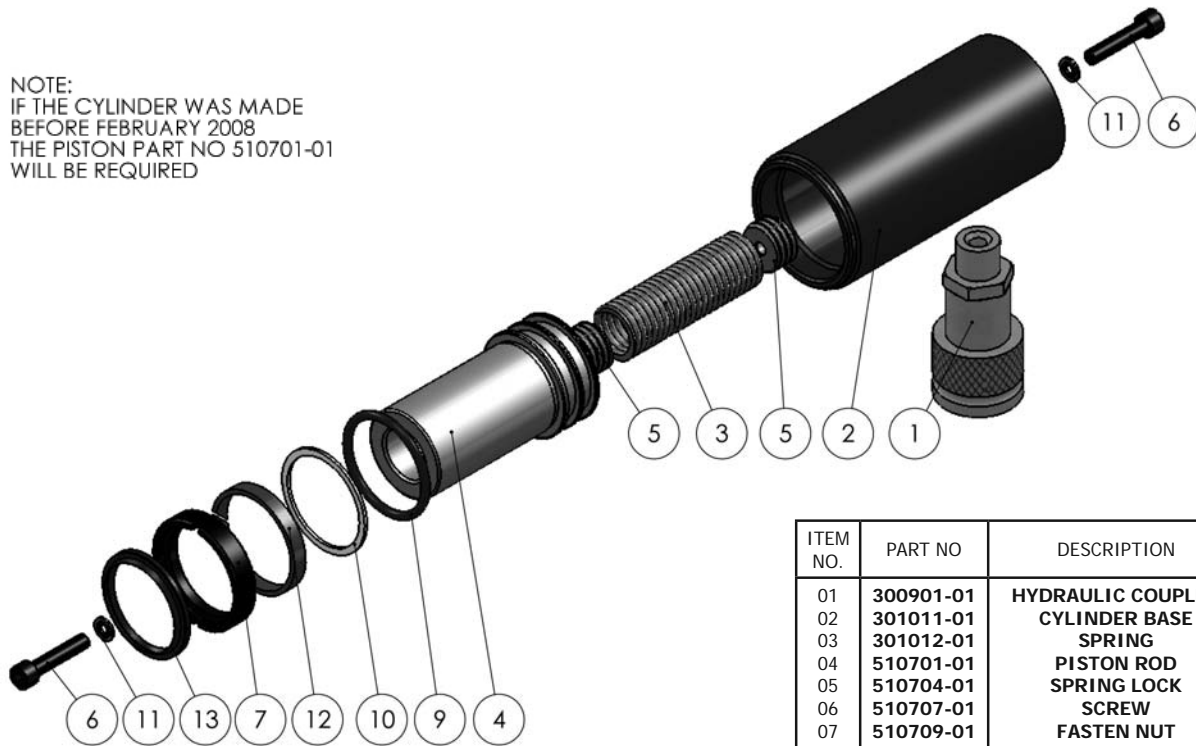

ITEM NO.	PART NO	DESCRIPTION	QTY.
01	300901-01	HYDRAULIC COUPLER	01
02	301011-01	CYLINDER BASE	01
03	301012-01	SPRING	01
04	510701-01	PISTON ROD	01
05	510704-01	SPRING LOCK	02
06	510707-01	SCREW	02
07	510709-01	FASTEN NUT	01
08	301403-01	SERVICE KIT	01
09		O-RING	01
10		BACK-UP RING	01
11		GASKET SEAL	02
12		SPLIT RING	01
13		WIPER	01



HP350S HYDRAULIC SINGLE PORT SEALED HAND PUMP

ITEM	PART No.	DESCRIPTION	KIT QUANTITY	PUMP QUANTITY
01	710101-01	PUMP HOUSING		01
02	715100-01	SERVICE KIT A:		
03		- OIL FILTER	01	01
04		- O-RING	01	01
05		- RESERVOIR BLADDER	01	01
06		- REFILLING PLUG	01	01
07	710601-01	RESERVOIR		01
08	725200-01	SERVICE KIT B:		
09		- TAIL BASE	01	01
10		- SCREW	04	04
11		- SPRING WASHER	04	04
12		- NUT	04	04
13	715300-01	SERVICE KIT C:		
14		- O-RING	01	01
15		- BACK-UP RING	01	01
16		- PUMP PISTON	01	01
17		- SNAP RING	01	01
18		- O-RING	01	01
19		- BACK-UP RING	01	01
20		- PUMP PISTON	01	01
21		- SNAP RING	01	01
22		- O-RING	01	01
23		- BACK-UP RING	01	01
24		- PUMP PISTON	01	01
25	715400-01	SERVICE KIT D:		
26		- HANDLE	01	01
27		- YOKE	01	01
28		- PISTON PIN	01	01
29		- YOKE PIN	01	01
30		- RETAINING RING	01	01
31		- HANDLE GRIP	01	01
32		- SCREW	01	01
33	715500-01	SERVICE KIT E:		
34		- YOKE BASE	01	01
35		- SPRING PIN	01	01
36	715600-01	SERVICE KIT F:		
37		- RELEASE VALVE	01	01
38		- SCREW	01	01
39		- WASHER	01	01
40		- SEAL	01	01
41		- SCREW	01	01
42		- RELEASE KNOB	01	01
43		- COUPLERS	01	01
44		- CHECK BALL	01	01
45	715700-01	SERVICE KIT G:		
46		- SPRING	02	02
47		- STEEL BALL	02	02
48		- OUTLET BALL SPRING	02	02
49		- COPPER WASHER	02	02
50		- VALVE COVER SCREW	02	02
51		- STEEL BALL	02	02

ITEM	PART No.	DESCRIPTION	KIT QUANTITY	PUMP QUANTITY
40	715800-01	SERVICE KIT H:		
41		- STEEL BALL	01	01
42		- SPRING END CAP	01	01
43		- L.P. SPRING	01	01
44		- O-RING	02	02
45		- OVERLOAD COVER	01	01
46		SCREW		
47		- CAP	02	02
48		- OVERLOAD COVER	01	01
49		SCREW		
50	715900-01	SERVICE KIT I:		
51		- BASE PLATE	01	01
52		- SCREW	02	02
53	716100-01	SERVICE KIT K:		
54		- SCREW	04	03
55		- SCREW	01	01
56		- SCREW	01	01
57		- CHECK BALL	04	03
58	716200-01	SERVICE KIT L:		
59		- GAUGE COUPLER	01	01
60		MALE		
61		- GAUGE	01	01
62	716300-01	SERVICE KIT M:		
63		- GAUGE COUPLER	01	01
64		FEMALE		
65		- COUPLER	01	01
66		- GAUGE PORT	01	01
67		ADAPTOR		

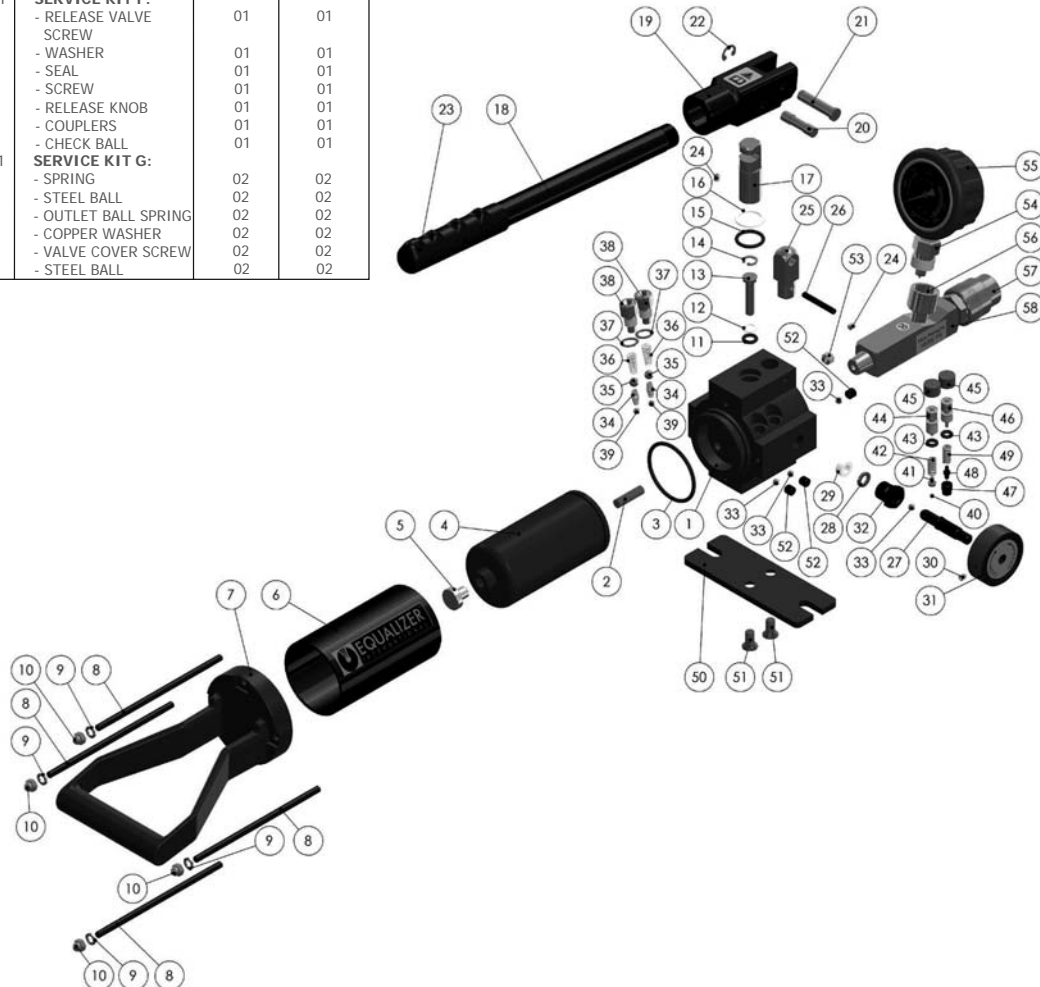



HP350D HYDRAULIC TWIN PORT SEALED HAND PUMP

ITEM	PART No.	DESCRIPTION	KIT QUANTITY	PUMP QUANTITY
01	720101-01	PUMP HOUSING		01
02	710601-01	RESERVOIR		01
	715100-01	SERVICE KIT A:		
03		- RESERVOIR BLADDER	01	01
04		- OIL FILTER	01	01
05		- O-RING	01	01
06		- REFILLING PLUG	01	01
	725200-01	SERVICE KIT B:		
07		- SCREW	04	04
08		- TAIL BASE	01	01
09		- SPRING WASHER	04	04
10		- NUT	04	04
	715300-01	SERVICE KIT C:		
11		- O-RING	01	01
12		- BACK-UP RING	01	01
13		- H.P. PISTON	01	01
14		- SNAP RING	01	01
15		- O-RING	01	01
16		- BACK-UP RING	01	01
17		- L.P. PISTON	01	01
	715400-01	SERVICE KIT D:		
18		- HANDLE	01	01
19		- YOKE	01	01
20		- PISTON PIN	01	01
21		- YOKE PIN	01	01
22		- RETAINING RING	01	01
23		- HANDLE GRIP	01	01
24		- SCREW	01	01
	715500-01	SERVICE KIT E:		
25		- YOKE BASE	01	01
26		- SPRING PIN	01	01
	715600-01	SERVICE KIT F:		
27		- RELEASE VALVE SCREW	01	01
28		- WASHER	01	01
29		- SEAL	01	01
30		- RELEASE KNOB	01	01
31		- SCREW	01	01
32		- COUPLERS	01	01
33		- CHECK BALL	01	01
	715700-01	SERVICE KIT G:		
34		- SPRING	02	02
35		- STEEL BALL	02	02
36		- OUTLET BALL SPRING	02	02
37		- COPPER WASHER	02	02
38		- VALVE COVER SCREW	02	02
39		- STEEL BALL	02	02
	715800-01	SERVICE KIT H:		
40		- STEEL BALL	01	01
41		- SPRING END CAP	01	01
42		- L.P. SPRING	01	01
43		- O-RING	02	02
44		- OVERLOAD COVER SCREW	01	01
45		- CAP	02	02
46		- OVERLOAD COVER SCREW	01	01
47		- CONE SEAT	01	01
48		- CONE	01	01
49		- LONG SEPARATOR SPRING	01	01

ITEM	PART No.	DESCRIPTION	KIT QUANTITY	PUMP QUANTITY
	715900-01	SERVICE KIT I:		
50		- BASE PLATE	01	01
51		- SCREW	02	02
	726000-01	SERVICE KIT J:		
52		- VALVE SCREW	01	02
53		- BACK-UP RING	01	02
54		- O-RING	01	02
30		- RELEASE KNOB	01	02
31		- SCREW	01	02
32		- COUPLERS	01	02
	716100-01	SERVICE KIT K:		
55		- SCREW	04	04
33		- CHECK BALL	04	04
	716200-01	SERVICE KIT L:		
56		- GAUGE COUPLER MALE	01	02
	716300-01	SERVICE KIT M:		
58		- GAUGE COUPLER FEMALE	01	02
59		- COUPLER	01	02
60		- PORT GAUGE ADAPTOR	01	02

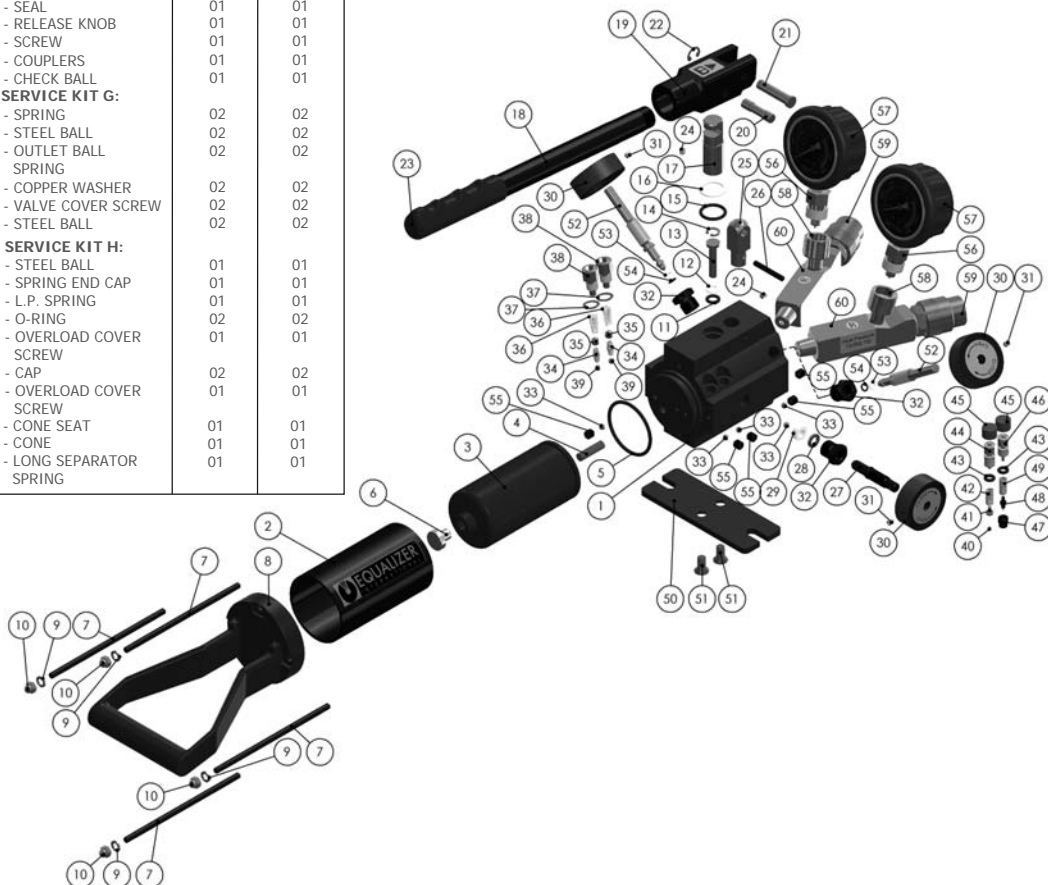



8.4 WEIGHTS AND DIMENSIONS

SW15TE Wedgehead with Hydraulic Cylinder
Carry-Case

= 7 kg (15.4 lbs)

= 6 kg (13.2 lbs)

MINI KIT GROSS WEIGHT
STANDARD KIT GROSS WEIGHT
MAXI KIT GROSS WEIGHT

= 7.5 kg (16.5 lbs)

= 19 kg (42 lbs)

= 30 kg (66.1 lbs)

Mini Kit Packaging Dimensions: 190 x 180 x 320 mm (7.48" x 7.09" x 12.60")

Standard Kit Carry-Case Dimensions: 920 x 520 x 210 mm (36.22" x 20.47" x 8.26")

Maxi Kit Carry-Case Dimensions: 920 x 520 x 210 mm (36.22" x 20.47" x 8.26")



MINIMUM EXTENSIONS

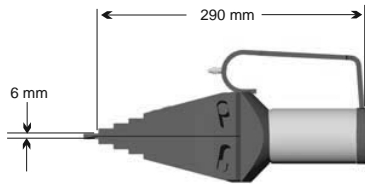

MAXIMUM EXTENSIONS

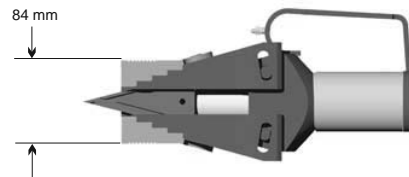
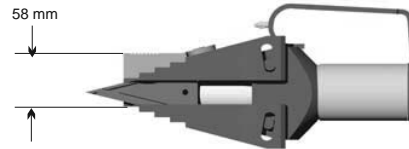
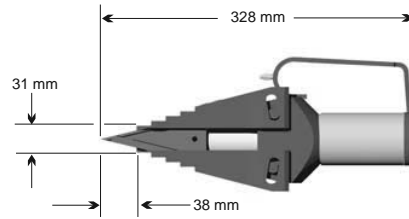

OVERALL DIMENSIONS

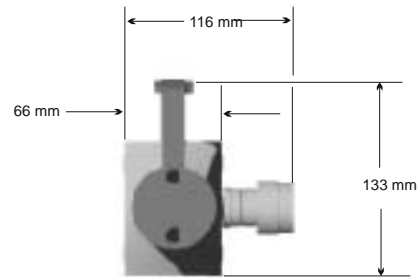
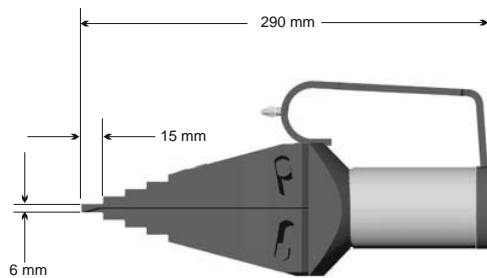

SAFETY BLOCK DIMENSIONS

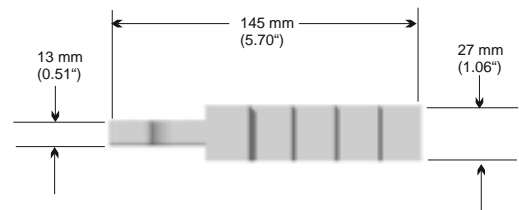
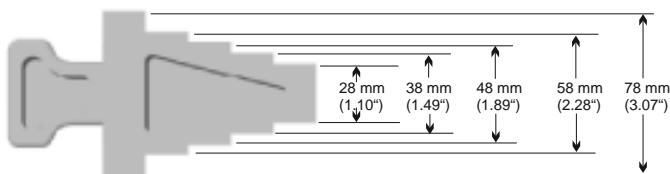



8.5 TROUBLESHOOTING

Problem: The wedge is advancing but does not reach full pressure

→ Air could be present in the hydraulic system

→ Use the airlock removal procedure as follows:

1. Connect the hand pump to the tool with the hydraulic hose
2. Close the release valve on the pump, and prime the pump until the hydraulic cylinder is fully extended and a small pressure is achieved
3. With the hand pump held above the tool and the tool in an upright position, open the release valve causing any air that is within the system to be forced up through the pump and vented into the oil reservoir
4. Repeat steps 1 - 3 three or four times to ensure that all air is removed from the system and the tool will reach full working pressure
5. Disconnect the hand pump from the hydraulic hose, grip the baseplate of the hand pump body in a vice with the pump body vertical and the main handle at the top
6. Remove the four nuts holding the main handle and lift off
7. Grip the refilling plug with pliers and extract it by pulling and twisting simultaneously. Ensure the reservoir body is held down when removing the refilling plug as pulling up on the reservoir body will release the bladder within, and oil will spill out.
8. Fill the reservoir to the top with a good quality hydraulic oil of the grade 15 cSt
9. Reinsert the refilling plug, wipe away any oil, and reassemble by reversing the disassembly process

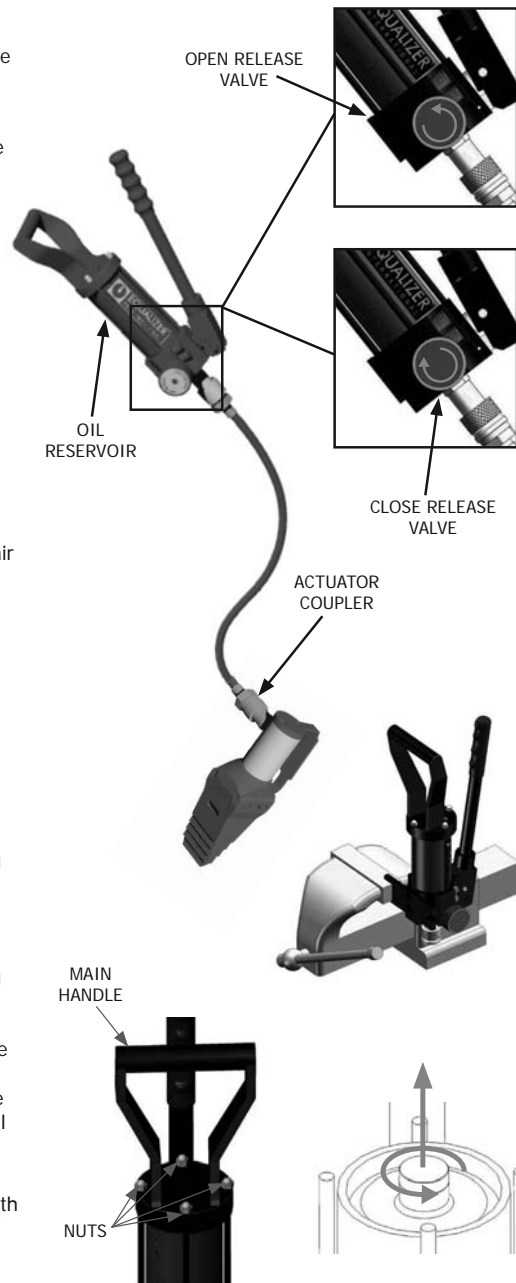



9. STEPPED BLOCK ACCESSORY

9.1 INSTALLATION AND OPERATION

The Equalizer Stepped Block enables the SW9TM, SW14.5TI and the SW15TE to be used in a joint with a larger gap, and to be used to open a joint further with less penetration (allowing, for example, spectacle blinds to be change with ease).

The stepped blocks can be used individually or as a pair.

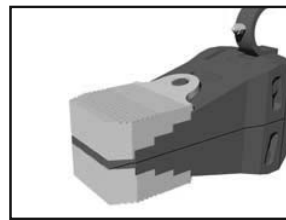
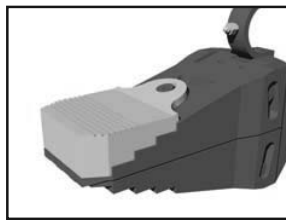

-
1. Attach the stepped block to the tool using the M6 countersunk screw

-
2. Insert the tool into the joint. Ensure there is a minimum hold of 15 mm (0.59") and that the full width of the block is used

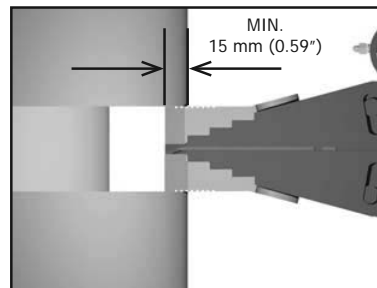



9.2 KIT COMPONENTS

2 x Stepped Blocks
2 x M6 Countersunk Screws
1 x 4 mm Hex Key



9.3 WEIGHTS AND DIMENSIONS

Stepped Block = 0.52 kg (1.14 lbs)

GROSS KIT WEIGHT = 1.5 kg (3.5 lbs)

