

HIGH TONNAGE AIR SERVICE JACK



LARZEP advantages

- From 60 to 150 Tn.
- Models with one stage and telescopic with two and three stages.
- Operated by an air/hydraulic pump. Air pressure required: 8 to 12 bar.
- Air inlet port: 1/2" BSP.
- Dual descent valve for greater control.
- Fitted with self sealing pneumatic tyres for easy manoeuvrability.
- Special hooks for transport.
- Ram return is automatic. Constant and controlled speed under load, can be increased without load.
- Check valves guarantee load holding, even if an air or oil pipe is accidentally broken.
- Equipped with an overpressure safety valve as protection against overloading.
- Three-position handle can be lowered to place the jack under the load.
- Easy to operate, with the control located on the end of handle.
- Wide range of optional accessories: remote pendant, manual emergency pump, safety load blocks, safety block holder, safety blocks kit, extensions and extension holder.



Safety block



Holder

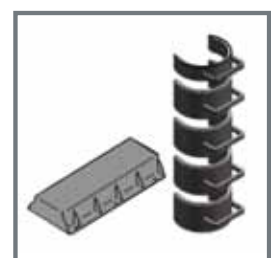

Kit

HIGH TONNAGE AIR JACKS

HL

60-150 Tn.

8-12 bar

AUTOMOTIVE

HL08042

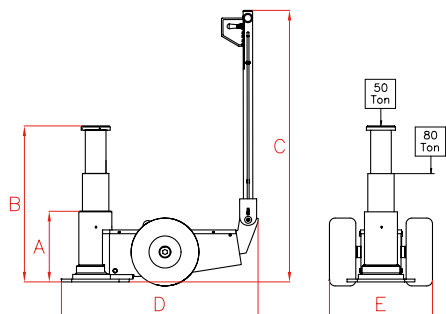

HL08052

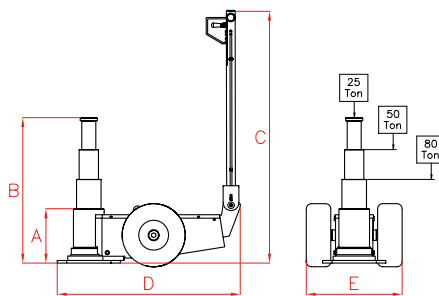

HL06022

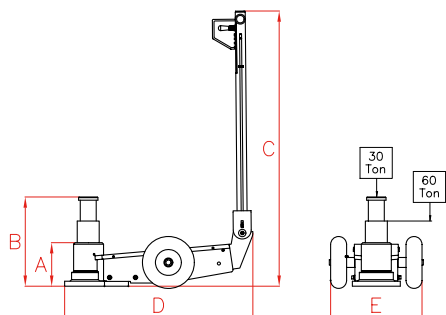

HL10044

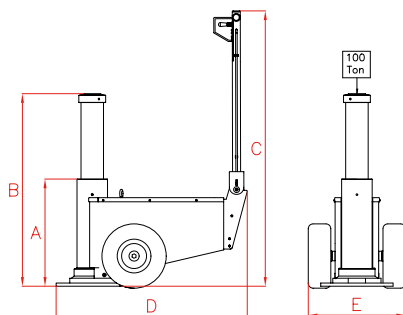

HL15055

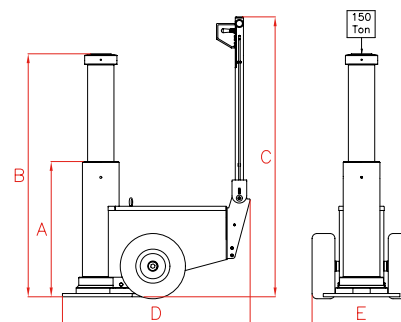

Capacity	Stroke	Model	A	B	C	D	E	Weight
Tn	mm	LARZEP	mm	mm	mm	mm	mm	kg
30/60	110+117	HL06022	220	447	1.385	940	460	93
50/80	196+222	HL08042	420	838	1.440	1.039	540	161
25/50/80	167+171+180	HL08052	341	859	1.440	1.040	540	143
100	445	HL10044	725	1.170	1.720	1.180	610	290
150	554	HL15055	900	1.454	1.720	1.250	620	385



Extensions



Extension Holder

ACCESORIES (Optional)

Model	Extension Holder		Extensions						
	Right	Left	10 mm	70 mm	120 mm	150 mm	200 mm	250 mm	300 mm
HL06022	-	-	HLE06001	HLE06007	HLE06012	-	-	-	-
HL08042	HLT080R	HLT080L	-	-	-	HLE08015	-	HLE08025	HLE08030
HL08052	HLT080R	HLT080L	-	-	-	HLE08015	-	HLE08025	HLE08030
HL10044	HLT150R	HLT150L	-	-	-	-	HLE15020	HLE15025	HLE15030
HL15055	HLT150R	HLT150L	-	-	-	-	HLE15020	HLE15025	HLE15030

Model	Safety Blocks				
	50mm M/F	100mm M/F	100mm F/F	Holder	Kit*
HL06022	-	-	-	-	-
HL08042	HLB05017M	HLB10017M	HLB10017F	HLC100	HLS100
HL08052	HLB05017M	HLB10017M	HLB10017F	HLC100	HLS100
HL10044	HLB05017M	HLB10017M	HLB10017F	HLC100	HLS100
HL15055	HLB05021M	HLB10021M	HLB10021F	HLC150	HLS150

Model	Remote Pendant	Manual Pump
All models	HLR	HLH



HLR



HLH

*Safety blocks kit **HLS100**: HLB05017M + 3xHLB10017M + HLB10017F + HLC100

*Safety blocks kit **HLS150**: HLB05021M + 4xHLB10021M + HLB10021F + HLC150