



EQUALIZERTM
INTERNATIONAL

FLANGE TOOL INNOVATION

PRODUCT DATA SHEET



SWi20/25TE INNOVATIVE EXTERNAL HYDRAULIC FLANGE SPREADING WEDGE

SPREADING FORCE:

20T (200kN) 1st step

25T (240kN) 4th step

SPREADING DISTANCE:

6.0 - 103.5mm (0.24 - 4.1")

WEIGHT: 6.4kg (14.02lb)

CAPABILITIES

At 10,000psi (700bar):

20T spread force (1st step)

24T spread force (4th step)

6.0mm – 87.5mm
(0.24" - 3.4") spread over 4 steps
(without stepped blocks)

48.5mm – 103.5mm
(1.9" - 4.1") spread over 2 steps
(with stepped blocks)

6.0mm – 40.0mm
(0.24" - 1.6") spread
using only 1st step



TOOL DIMENSIONS - CLOSED

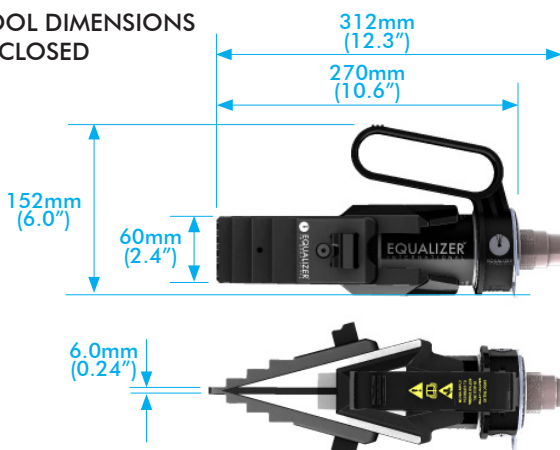

USER FEATURES

- Practical, portable and lightweight
- Moulded plastic handle for comfort
- Revolving handle to aid horizontal or vertical spreading
- Offset handle is directly over the centre of mass
- Removable handle for improved access
- Revolving lanyard connection point
- Swivel hose coupler with elbow – improves access by allowing hose to revolve
- Spread indicator markings for clear precise visual progress feedback

SAFETY FEATURES

- No finger pinch-points
- Increased step depth on upper steps
- Safety lanyard – 1.0m (39") length
- Partially recessed coupler reduces coupler vulnerability
- Forged key components for strength and reliability
- Fail-safe design – designated cylinder nose seal failure

MAINTENANCE FEATURES

- Rapid disassembly and assembly
- Quick jaw replacement – remove 1 fastener
- Quick tip replacement – remove 2 fasteners
- Narrow jaw teeth – improved tool wear

info@equalizerinternational.com
www.equalizerinternational.com

SWi20/25TE

INNOVATIVE EXTERNAL HYDRAULIC
FLANGE SPREADING WEDGE



FLANGE TOOL INNOVATION

JAW DIMENSIONS (WITHOUT STEPPED BLOCKS ATTACHED)

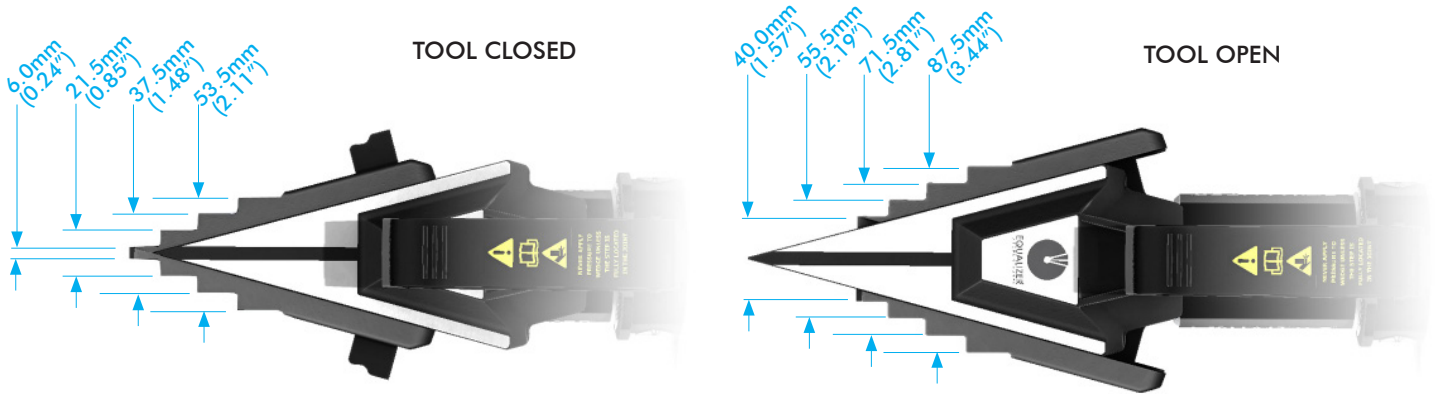

JAW DIMENSIONS (WITH STEPPED BLOCKS ATTACHED)

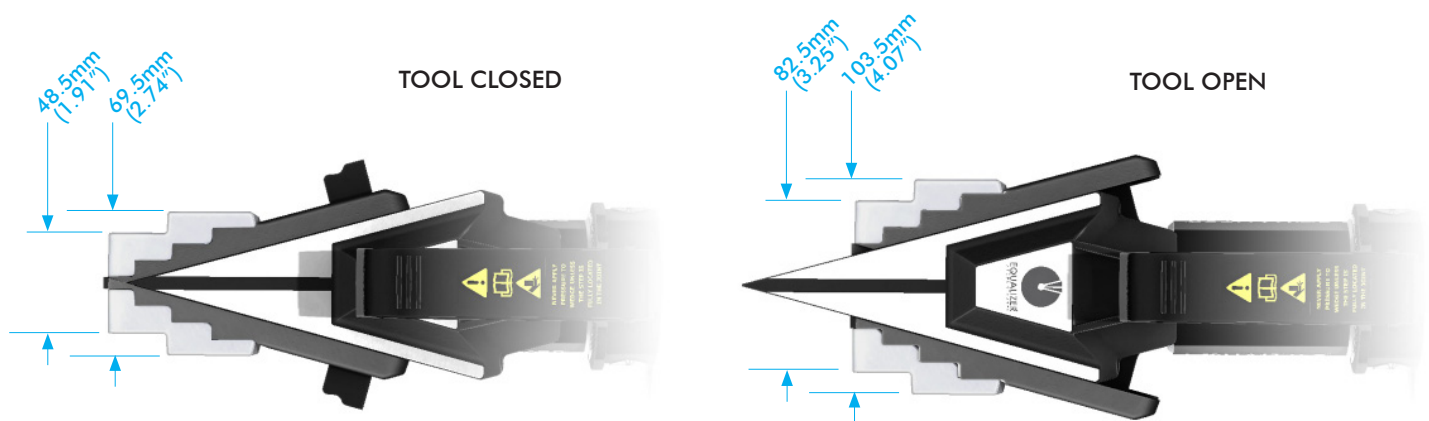

MAXI KIT

- 2 x SWi20/25TE Flange Spreader Wedgeheads
- 2 x 10,000psi (700bar) Hydraulic Cylinders
- 2 x 10,000psi (700bar) Hydraulic Hoses, 2m (78.75") with 90 degree elbow
- 1 x 10,000psi (700bar) HP550D Sealed Hand Pump with Gauges
- 2 x Sets of Safety Blocks
- 2 x Pairs of Stepped Blocks
- 2 x Hex Keys
- 2 x Lanyards
- 1 x Instruction Manual
- 1 x Plastic Carry Case

920mm x 500mm x 205mm (36.2" x 19.7" x 8.1")
Gross Kit Weight 33.0kg (72.8lb)
Product Code: SWi2025TEMAXSPB



STANDARD KIT

- 1 x SWi20/25TE Flange Spreader Wedgehead
- 1 x 10,000psi (700bar) Hydraulic Cylinder
- 1 x 10,000psi (700bar) Hydraulic Hose, 2m (78.75") with 90 degree elbow
- 1 x 10,000psi (700bar) HP350S Sealed Hand Pump with Gauge
- 1 x Set of Safety Blocks
- 1 x Pair of Stepped Blocks
- 1 x Hex Key
- 1 x Lanyard
- 1 x Instruction Manual
- 1 x Plastic Carry Case

920mm x 500mm x 205mm (36.2" x 19.7" x 8.1")
Gross Kit Weight 20.7kg (45.7lb)
Product Code: SWi2025TESTDSPB



MINI KIT

- 1 x SWi20/25TE Flange Spreader Wedgehead
- 1 x 10,000psi (700bar) Hydraulic Cylinder
- 1 x Set of Safety Blocks
- 1 x Pair of Stepped Blocks
- 1 x Hex Key
- 1 x Lanyard
- 1 x Instruction Manual
- 1 x Plastic Carry Case

580mm x 330mm x 165mm (22.8" x 13.0" x 6.5")
Gross Kit Weight 11.6kg (25.6lb)
Product Code: SWi2025TEMIN