



"innovation in its most functional form"

PRODUCT DATA SHEET

SW14.5TI

INTEGRAL HYDRAULIC FLANGE SPREADER

SPREADING FORCE:

10,000 psi (700 bar) = 14.5 T (145 kN)

It is recommended that tools are used in pairs giving
 $2 \times 14.5 = 29 \text{ T (290 kN)}$

TOOL WEIGHT = 9 kg (19.8 lbs)

KIT COMPONENTS

- 1 x SW14.5TI Wedgehead
 - 1 x 10,000 psi (700 bar) Integral Hydraulic Pump/Cylinder
 - 1 x Safety Block
 - 1 x Pair of Stepped Blocks
 - 1 x Carry-Strap
 - 1 x Instruction Manual
 - 1 x Carry Case
- Product Code: SW14.5TISPB



WEIGHTS AND DIMENSIONS

- Wedge with Integral Hydraulic Pump Cylinder = 9 kg (19.8 lbs)
- Carry Case = 2.5 kg (5.5 lbs)
- Gross Weight = 14 kg (28.6 lbs)

Carry-Case Dimensions:
580 x 340 x 180mm (22.8" x 13.4" x 7")

TOOL DIMENSIONS - CLOSED



TOOL DIMENSIONS - OPEN

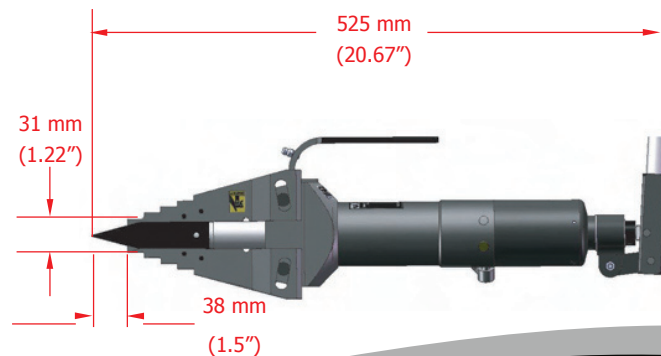

info@equalizerinternational.com
www.equalizerinternational.com

SW14.5TI

INTEGRAL HYDRAULIC FLANGE SPREADER



"innovation in its most functional form"



SAFETY BLOCK DIMENSIONS

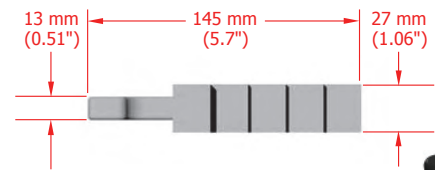
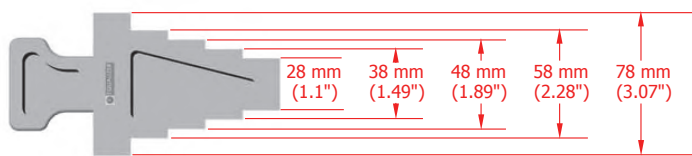

PARTS LIST AND EXPLODED DRAWING

| ITEM | PART No. | DESCRIPTION | QUANTITY |
|------|-----------|---------------------------------|-------------|
| 01 | | SERIAL NO STICKER | 01 each |
| 02 | | QC SEALED STICKER | 02 each |
| 03 | | PINCH POINT STICKER | 02 each |
| 04 | | GREASE POINT STICKER | 02 each |
| 05 | | READ INSTR. STICKER | 01 each |
| 06 | | BADGE LOGO | 02 each |
| 07 | 300101-01 | WEDGE | 01 each |
| 08 | 300301-01 | PUSH PIN | 01 each |
| 09* | | M5X6 SCKT SCREW | 01 set of 4 |
| 10* | | SLIDE PIN | 01 set of 4 |
| 11 | 301102-01 | MAIN BODY | 01 each |
| 12* | | SPIROL PIN | 01 set of 8 |
| 13* | | M6X12 GRUB SCREW | 01 each |
| 14 | 308201-01 | HANDLE | 01 each |
| 15 | 310601-01 | M6 GREASE NIPPLE | 01 each |
| 16 | 311601-01 | SPLIT RING | 01 set of 2 |
| 17 | 312302-01 | HANDLE SLEEVE | 01 each |
| 18 | 300203-02 | FORGED JAW | 01 set of 2 |
| 19* | | 5/16" SCREW | 01 each |
| 20 | 510701-01 | INT. PUMP & CYLINDER | 01 each |
| 21 | 375010-01 | SERVICE KIT A (Not illustrated) | 01 kit |
| 22 | 375020-01 | SERVICE KIT C (Not illustrated) | 01 kit |
| 23 | 510700-01 | SERVICE KIT D (Not illustrated) | 01 kit |



*Items 09,10,12,13 and 19 are supplied in repair kit part no: 310301-01

STEPPED BLOCKS

Stepped Blocks can be used singly or in pairs to increase the maximum spreading distance of the SW9TM to 81mm

STEPPED BLOCK KIT (AVAILABLE AS AN OPTION)

KIT COMPONENTS

- 2 x Stepped Blocks
- 2 x M6 x 10 mm Countersunk Screws
- 1 x 4mm Hex Key
- Kit Part No: 303301-01

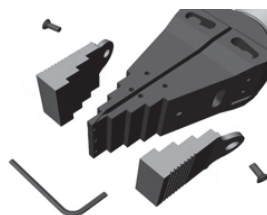

WEIGHTS AND DIMENSIONS

- Stepped Block = 0.52 kg (1.14 lb)
- GROSS WEIGHT = 1.5 kg (3.5 lb)

